



WL4G2F330

SICK
Sensor Intelligence.



Illustration may differ

Ordering information

Type	Part no.
WL4G2F330	1016209

Other models and accessories → www.sick.com/

Detailed technical data

Features

Functional principle	Photoelectric retro-reflective sensor
Dimensions (W x H x D)	16 mm x 32 mm x 12 mm
Housing design (light emission)	Rectangular
Sensing range max.	0.05 m ... 1.6 m ¹⁾
Sensing range	0.05 m ... 1 m ¹⁾
Type of light	Visible red light
Light source	LED
Adjustment	Cable Single teach-in button

¹⁾ Reflector PL80A.

Mechanics/electronics

Supply voltage	10 V DC ... 30 V DC
Ripple	< 5 V _{pp}
Current consumption	20 mA ¹⁾
Switching output	PNP
Switching mode	Dark switching
Response time	< 500 μs ²⁾
Connection type	Connector M8, 3-pin
Housing material	Plastic, ABS
Optics material	Plastic, PMMA
Enclosure rating	IP67
Ambient operating temperature	-40 °C ... +60 °C
Ambient temperature, storage	-40 °C ... +75 °C

¹⁾ Without load.

²⁾ Signal transit time with resistive load.

Connection type

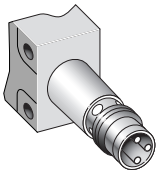

Adjustments

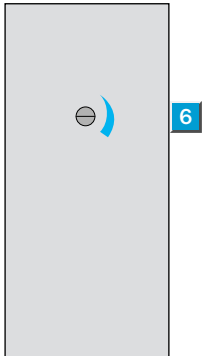

⑥ Adjustment of sensing range

Dimensional drawing (Dimensions in mm (inch))

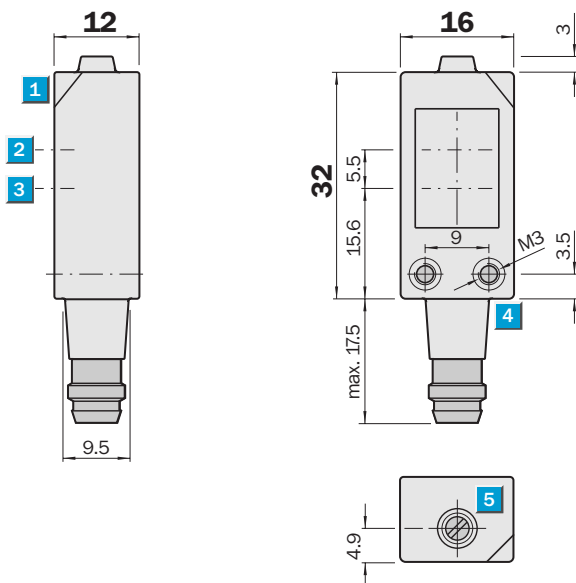

- ① LED signal strength indicator
- ② Optical axis, receiver
- ③ Optical axis, sender
- ④ Standard direction of the material being detected
- ⑤ Threaded mounting hole M3
- ⑥ Adjustment of sensing range

SICK AT A GLANCE

SICK is one of the leading manufacturers of intelligent sensors and sensor solutions for industrial applications. A unique range of products and services creates the perfect basis for controlling processes securely and efficiently, protecting individuals from accidents and preventing damage to the environment.

We have extensive experience in a wide range of industries and understand their processes and requirements. With intelligent sensors, we can deliver exactly what our customers need. In application centers in Europe, Asia and North America, system solutions are tested and optimized in accordance with customer specifications. All this makes us a reliable supplier and development partner.

Comprehensive services complete our offering: SICK LifeTime Services provide support throughout the machine life cycle and ensure safety and productivity.

For us, that is “Sensor Intelligence.”

WORLDWIDE PRESENCE:

Contacts and other locations –www.sick.com