

DL100 – SSI

Distance measuring device



EN



Copyright protection!

This work is copyright-protected. The rights founded by this shall remain with company SICK AG. Reproduction of the work shall only be permissible within the limits of the legal provisions of copyright law. Changes and abbreviations of this work are prohibited without the express written agreement of SICK AG.

Table of contents

Important safety notes	7
Importantes consignes de sécurité	7
1 General	8
1.1 Information on the operating instructions	8
1.2 Explanation of symbols	9
1.3 Limitations of liability	10
1.4 Delivery.....	10
1.5 Customer service.....	10
1.6 EC Declaration of Conformity.....	11
1.7 Environmental protection.....	11
2 Safety	12
2.1 Intended use.....	12
2.2 Non-Intended use	12
2.3 Changes and conversions	12
2.4 Requirements to skilled persons and operating staff	13
2.5 Work safety and special danger	13
2.6 Warning at the device.....	14
2.7 Danger notes and operational safety.....	15
3 Identification	16
3.1 Type label	16
4 Setup and function	17
4.1 Setup	17
4.2 Function.....	18
4.3 Display and operating elements.....	19
4.4 Display	20
5 Transport and storage	21
5.1 Transport.....	21
5.2 Transport inspection.....	21
5.3 Storage	22
6 Mounting	23
6.1 Mounting process	23
6.2 Mounting notes.....	23
6.3 Choose and mount reflector	24
6.4 Placement of multiple distance measuring devices	25

Table of contents

6.5	Place the distance measuring device towards the adjacent data transmission photoelectric switch.....	27
6.6	Align distance measuring device and reflector against each other	28
6.7	Mount alignment bracket and distance measuring device .	29
6.8	Distance measuring device above alignment bracket	31
7	Electrical connection	32
7.1	Safety.....	32
7.2	Wiring notes	32
7.3	Electrically connect distance measuring device.....	36
7.4	Connection diagrams	37
7.4.1	Connection diagram supply voltage	37
7.4.2	Connection diagram Ethernet.....	38
8	Operation at the measuring device	39
8.1	Measured value display	39
8.2	Choose parameter.....	39
8.3	Choose option.....	39
8.4	Change value	40
8.5	Parameter description.....	40
8.5.1	Main menu	40
8.5.2	Menu "SwVers".....	41
8.5.3	Menu "HwVers".....	41
8.5.4	Menu "SSI"	42
8.5.5	Menu "more"	43
8.5.6	Menu "MFx On"	43
8.5.7	Menu "MF1"	44
8.5.8	Submenu "MF1 – Dist".....	45
8.5.9	Submenu "MF1 – Speed".....	46
8.5.10	Submenu "MF1 – Srvce"	47
8.5.11	Submenu "MF1 - Preset" – move to initialization position.....	49
8.5.12	Menu "MF2"	50
8.5.13	Menu "Offset"	51
8.5.14	Menu "SpecFu".....	52
8.6	Perform reset.....	53
9	Operation via Ethernet (Ethernet interface)	54
9.1	IP-network configuration	54

9.2	Ethernet parameter list	55
9.2.1	Device information.....	55
9.2.2	User information	56
9.2.3	Measured data.....	57
9.2.4	Diagnostic data	58
9.2.5	Parameter settings	59
9.2.6	Methods	66
10	Interface "SSI".....	67
10.1	Basics	67
10.2	SSI protocol (data format).....	68
11	Cleaning and maintenance	69
11.1	Cleaning	69
11.2	Maintenance	69
12	Troubleshooting	70
12.1	LED status indicators	70
12.2	Warning messages	71
12.3	Error messages.....	71
12.4	Return.....	72
12.5	Disposal.....	72
13	Repair.....	72
14	Technical data.....	73
14.1	Dimensions	74
14.2	Device selection for the SSI interface	75
14.3	Laser/optics.....	75
14.4	Performance	76
14.5	Supply.....	76
14.6	Inputs.....	76
14.7	Outputs.....	76
14.8	Interfaces	77
14.9	Ambient conditions.....	77
14.10	Constructive setup.....	78
15	Accessories	79
15.1	Reflectors and reflective tape	79
15.1.1	Reflectors	79
15.1.2	Reflective tape	81
15.2	Connection systems	82

Table of contents

15.2.1	Cable sockets, straight, with cables	82
15.2.2	Cable.....	83
15.3	Mounting systems.....	84
15.4	Other accessories.....	85
16	Menu structure.....	86
	Index	88

Important safety notes



NFPA79 applications only.

UL-listed adapters providing field wiring leads are available.

Refer to the product information.

→ See "www.sick.com/Dx100".



CAUTION!

Use of controls or adjustments or performance of procedures other than those specified herein may result in hazardous radiation exposure.

Importantes consignes de sécurité



À utiliser pour les applications NFPA79 uniquement.

Des adaptateurs homologués fournissant des fils de câblage client sont disponibles.

Se reporter aux informations du produit.

→ Voir « www.sick.com/Dx100 ».



ATTENTION!

Tout usage de commandes, réglages ou toute application de procédures autres que ceux décrits dans ce document peut entraîner une exposition dangereuse au rayonnement.

General

1 General

1.1 Information on the operating instructions

These operating instructions offer important notes on handling of the distance measuring devices DL100 of SICK AG. A prerequisite for safe work is compliance with all indicated safety notes and instructions.

Furthermore, the local work safety regulations and general safety provisions applicable for the application of the distance measuring device must be complied with.

The operating instructions must be read carefully before taking up any work! It is part of the product and must be kept in direct proximity of the distance measuring device, accessible for the staff at all times.

When passing on the distance measuring device to third parties, the operating instructions must be passed on as well.



NOTE!

These operating instructions describe all distance measuring devices DL100 with a SSI interface.

1.2 Explanation of symbols

Warnings

Warnings are marked by icons in the operating instructions. The notes are initiated by signal words that express the degree of danger.

Always comply with the notes and act carefully to avoid accidents, injury and property damage.



DANGER!

... indicates a directly dangerous situation that will lead to death or severe injury if not avoided.



WARNING!

... indicates a possibly dangerous situation that may lead to death or severe injury if not avoided.



CAUTION!

... indicates a potentially dangerous situation that may lead to minor or light injury if not avoided.



ATTENTION!

... indicates a potentially harmful situation that may lead to property damage if not avoided.

Advice and recommendations



NOTE!

... emphasizes useful advice and recommendations, as well as information for efficient and trouble-free operation.

General

1.3 Limitations of liability

All notes and information in these instructions were collected under consideration of the applicable standards and regulations, the state of the art and our long-term experience and insights.

The manufacturer does not assume any liability for damage due to:

- Non-observant of the operating instructions
- Non-intended use
- Use of untrained staff
- Unauthorized conversions
- Technical changes
- Use of unapproved wear and tear parts

The actual delivery may deviate from the features and presentations described here for special designs, when additional order options are used or due to the latest technical changes.

1.4 Delivery

The following is included in the delivery:

- Distance measuring device DL100
- Optional: Accessories (→ page 79, chapter 15).

Included documentation per distance measuring device:

- Quickstart

1.5 Customer service

Our customer service is available for technical information.

You can find your local office on the reverse.



NOTE!

For quick processing of the call, keep the data of the type label, such as type code, serial number, etc. ready.

1.6 EC Declaration of Conformity

→ The EC Declaration of Conformity can be downloaded from "www.sick.com/Dx100".

1.7 Environmental protection



ATTENTION!

Danger for the environment from improper disposal of the distance measuring device!

Improper disposal of the distance measuring device may cause damage for the environment.

Therefore:

- Always observe the applicable environmental protection provisions.
 - Upon proper disassembly, send the disassembled components to recycling.
 - Separate the materials by type and recycle them.
-

Safety

2 Safety

2.1 Intended use

The distance measuring device DL100 is a measuring device considering of an opto-electronic sensor and integrated assessment electronics. The measuring device is only intended for non-contact recording of distances from linearly moved system parts. The distance measurement is performed by a reflector.

SICK AG assumes no liability for direct or indirect loss or damage resulting from use of the product. This in particular applies for any differing use of the product that does not meet the intended purpose and that is not described or mentioned in this documentation.

2.2 Non-Intended use

The distance measuring device DL100 is no safety component according to the EC Machinery Directive (2006/42/EC).

The distance measuring devices must not be used in explosion-hazardous areas.

All uses not described in intended use are prohibited.

No accessories must be connected or installed that are not expressly specified in amount and characteristics and approved by SICK AG.



WARNING!

Danger from non-intended use!

Any non-intended use may cause dangerous situations.

Therefore:

- Only use the distance measuring device according to its intended use.
 - All information in the operating instructions must be strictly complied with.
-

2.3 Changes and conversions

Changes and conversions at the distance measuring device or the installation may cause unexpected dangers.

The manufacturer's written approval is required before any technical changes and expansions of the distance measuring device.

2.4 Requirements to skilled persons and operating staff



WARNING!

Danger of injury in case of insufficient qualification!

Improper use may cause considerable injury and property damage.

Therefore:

- Any work must be performed by the designated persons only.

The following qualification requirements for the different areas of activity are described in the operating instructions:

- **Instructed persons**
were instructed in the tasks assigned to them and possible dangers in case of improper conduct in the scope of instruction by the operator.
- **Skilled persons**
are able to perform the tasks assigned to them based on their technical training, knowledge and experience, as well as knowledge of the relevant provisions, and to independently recognize possible danger.
- **Electricians**
are able to perform work at electrical systems based on their technical training, knowledge and experience, as well as knowledge of the relevant standards and provisions, and to independently recognize possible dangers.
In Germany, the electrician must meet the provisions of the accident prevention provisions BGV A3 (e.g. Elektroinstallateur-Meister). Other countries are subject to corresponding regulations that must be observed.

2.5 Work safety and special danger

Observe the safety notes listed here and the warnings in the other chapters of these instructions to reduce dangers to health and avoid dangerous situations.

Safety

2.6 Warning at the device

The distance measuring device DL100 has a category 2 laser installed. The measuring device is marked with a warning.

<p>EN/IEC 60825-1:2014 Complies with 21 CFR 1040.10 and 1040.11 except for deviations pursuant to laser notice No. 50, date June 24, 2007</p>	<p>Complies with 21CFR1040.10 and 1040.11 except for deviations pursuant to laser notice No. 50, date June 24, 2007</p>
	<p>Laser radiation - Do not look into the laser beam - Laser class 2 (EN/IEC 60825-1:2014)</p>
	<p>Laser aperture</p>
<p>MEAN OUTPUT P₀ < 1mW CW-MODULATION ± 0.85 P₀ WAVELENGTH = 655nm FREQUENCY ≥ 90 MHz</p>	

Fig. 1: Warning at the device: Laser category 2 (EN/IEC 60825-1:2014)
Identical laser class for issue EN/IEC 60825-1:2007

2.7 Danger notes and operational safety

Laser irradiation

The following notes must be observed and complied with for your own safety:

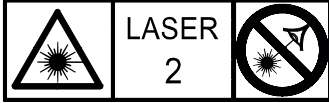
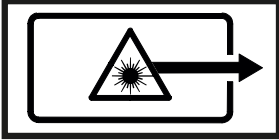

CAUTION!

Optical radiation: Laser class 2

The human eye is not at risk when briefly exposed to the radiation for up to 0.25 seconds. Exposure to the laser beam for longer periods of time may cause damage to the retina. The laser radiation is harmless to human skin.

- Do not look into the laser beam intentionally.
- Never point the laser beam at people's eyes.
- If it is not possible to avoid looking directly into the laser beam, e.g., during commissioning and maintenance work, suitable eye protection must be worn.
- Avoid laser beam reflections caused by reflective surfaces. Be particularly careful during mounting and alignment work.
- Do not open the housing. Opening the housing will not switch off the laser. Opening the housing may increase the level of risk.
- Current national regulations regarding laser protection must be observed.

Identification

3 Identification

3.1 Type label

The type label is located on the measuring device.

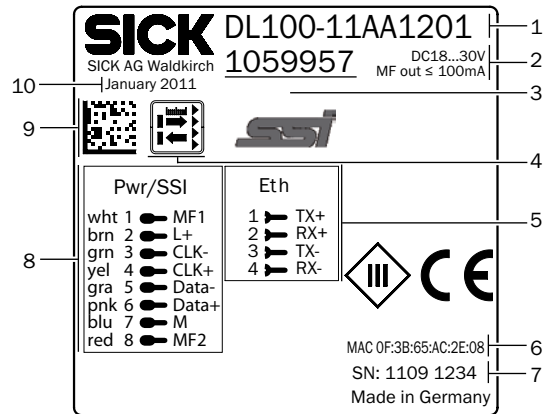

Fig. 2: Type Label

- 1 Type code → See page 75, chapter 14.2.
- 2 Supply voltage, multifunction output current
- 3 Device number
- 4 Icon: Distance sensor reflector mode
- 5 Assignment for female connector Ethernet
- 6 MAC address
- 7 Serial number
- 8 Assignment for supply voltage plug and SSI
- 9 Barcode
- 10 Production year and month

4 Setup and function

4.1 Setup

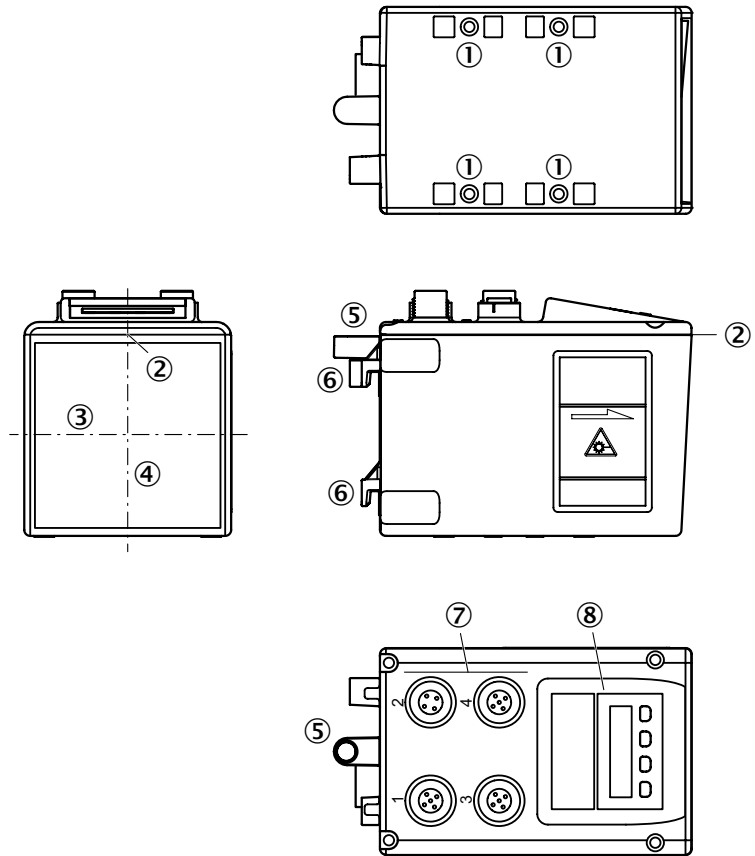

Fig. 3: Setup "Distance measuring device DL100"

- 1 Threaded mounting hole M5
- 2 Device zero point
- 3 Optical axis sender
- 4 Optical axis receiver
- 5 Bore for knurled screw of the optional alignment bracket
- 6 Holder for optional alignment bracket
- 7 Electrical connection
- 8 Display and operating unit

Setup and function

4.2 Function

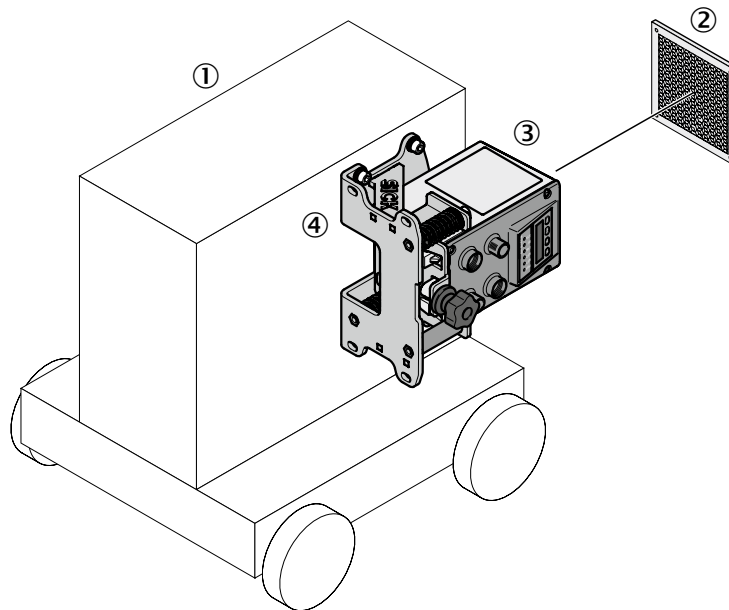

Fig. 4: Function "Distance measuring device DL100"

- 1 Vehicle
- 2 Reflector
- 3 Distance measuring device DL100
- 4 Alignment bracket

The distance measuring device DL100 comprises optics, a sender/receiver unit and an evaluation unit. The sender emits the laser beam. The receiver receives the light reflected by the reflector. The evaluation electrical unit determines the distance between sensor and reflector by time of flight measurement.

For measurement, either the reflector or the measuring device may move linearly along the laser beam.

The measured distance is transferred via the "SSI" interface and may be used, e.g. for the control unit or a position-control circuit.

4.3 Display and operating elements

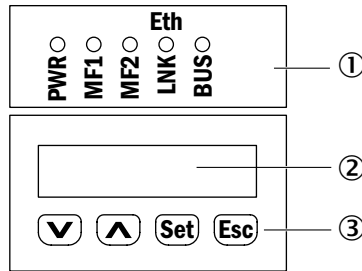

Fig. 5: Display and operating elements

- 1 LEDs
- 2 Display
- 3 Keys

LEDs

LED	Description
PWR	Display of operating status <ul style="list-style-type: none"> • LED off: No operation • LED green: Trouble-free operation • LED orange flashing: Warning (see warning status, upper level menu) • LED red flashing: Interference (see error status, menu on the top level) → Troubleshooting, see page 70, chapter 12.
MF1	Multifunctional input/output MF1 <ul style="list-style-type: none"> • LED on: Output high • LED off: Output low
MF2	Multifunction output MF2 <ul style="list-style-type: none"> • LED on: Output high • LED off: Output low
LNK	Ethernet <ul style="list-style-type: none"> • LED off: No Ethernet present • LED green: Ethernet present • LED orange flashing: Data transmission
BUS	Interface (SSI) <ul style="list-style-type: none"> • LED on: SSI-cycle present • LED off: No SSI cycle present

Table 1: LEDs

Setup and function

Symbols for operating modes

The distance measuring device differentiates between the two operating modes "measured value display" and "menu operation".

Icon	Description
RUN	The icon RUN is displayed in the operating mode "measured value display". If there is an error and no measurement value can be determined, the icon RUN disappears.
MEN	The icon MEN is displayed in the operating mode "menu operation". The icon is also displayed when there is an error and no measurement value can be determined.

Table 2: Symbols for operating modes

Keys





Key	Description
	<ul style="list-style-type: none"> Select menu, parameters or options. Reduce value.
	<ul style="list-style-type: none"> Select menu, parameters or options. Increase value.
	<ul style="list-style-type: none"> Switch to the next lower menu level. Save parameter change. Confirm selection.
	<ul style="list-style-type: none"> Leave parameter without saving. Switch to the next higher menu level.

Table 3: Keys

4.4 Display

Measured value display

The measurement value is displayed by default:

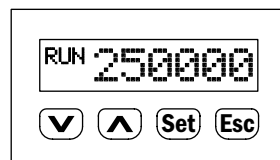

Fig. 6: Measured value display

Menu display



Fig. 7: Menu display



NOTE!

is a value or display that has more than six characters, the characters are automatically displayed in sequence.

5 Transport and storage

5.1 Transport

Improper transport



ATTENTION!

Damage to the distance measuring device by improper transport!

Improper transport may cause considerable property damage.

Therefore:

- Only have transport performed by trained workers.
 - When unloading and during internal transport, always proceed with the greatest care and caution.
 - Observe icons on the packaging.
 - Only remove packaging right before commencement of installation.
-

5.2 Transport inspection

Improper transport

Inspect the delivery for completeness and transport damage without delay upon receipt.

If there is any externally visible transport damage, proceed as follows:

- Do not accept the delivery, or only under reservation.
 - Note the scope of the damage on the transport documents or the delivery receipt of the transporter.
 - Initiate complaints.
-



NOTE!

Report every defect as soon as you recognize it. Damages claims can only be asserted within the applicable complaint periods.

Transport and storage

5.3 Storage

Store the distance measuring device under the following conditions:

- Do not leave it outside.
- Store dry and dust-free.
- Do not expose to any aggressive media.
- Protect from solar irradiation.
- Avoid mechanical vibrations.
- Storage temperature: –40 to +75 °C
- Relative humidity: max. 95 %, non-condensing
- At storage exceeding 3 months, regularly inspect the general condition of all components and the packaging.

6 Mounting

6.1 Mounting process

1. Determine mounting site under consideration of the mounting notes.
→ See following chapter.
2. Mount alignment bracket and distance measuring device.
→ See page 29, chapter 6.7.
3. Perform electrical connection.
→ See page 32, chapter 7.
4. Align distance measuring device and reflector against each other.
→ See page 28, chapter 6.6.
5. Align distance measuring device with the reflector using the alignment bracket fine adjustment. → See page 31, chapter 6.8.
6. Fasten alignment of the distance measuring device.
→ See page 31, chapter 6.8.

6.2 Mounting notes

Observe the following mounting notes for trouble-free operation:

- Comply with technical specifications like the measurement range.
→ See page 76, chapter 14.4.
- Use distance measuring device with optional heating in low ambient temperatures, e.g. in deep freeze storage.
- At higher temperatures, use the distance measuring device with optional cooling casing. → See page 85, chapter 15.5.
- Protect the distance measuring device from solar irradiation.
- To avoid condensation, do not expose the distance measuring device to any quick temperature changes.
- Observe the assembly notes for the reflector.
→ See page 23, chapter 6.2.
- Keep sufficient distance to other distance measuring devices.
→ See page 25, chapter 6.4.
- Keep sufficient distance to data transmission photoelectric switches.
→ See page 27, chapter 6.5.

Mounting

6.3 Choose and mount reflector



NOTE!

→ For suitable reflectors and suitable reflective tape, see page 79, chapter 15.1.

Reflector size

- Select the reflector size so that the light spot does still meet the reflector in case of vibrations.
- If the reflector is installed at a vehicle, a smaller reflector is typically sufficient.

Requirements

- Highly reflective surfaces close to the reflector can cause beam deflections or stray light and thus lead to incorrect measurements. Highly reflective surfaces may be, among others, shelf profiles, palettes rapped with stretch foil and running rails.

Align the reflector as follows:

- According to the following figure away from the shiny surface
- Depending on placement with an inclination of approx. 1° to 3° in the X- or Y-direction

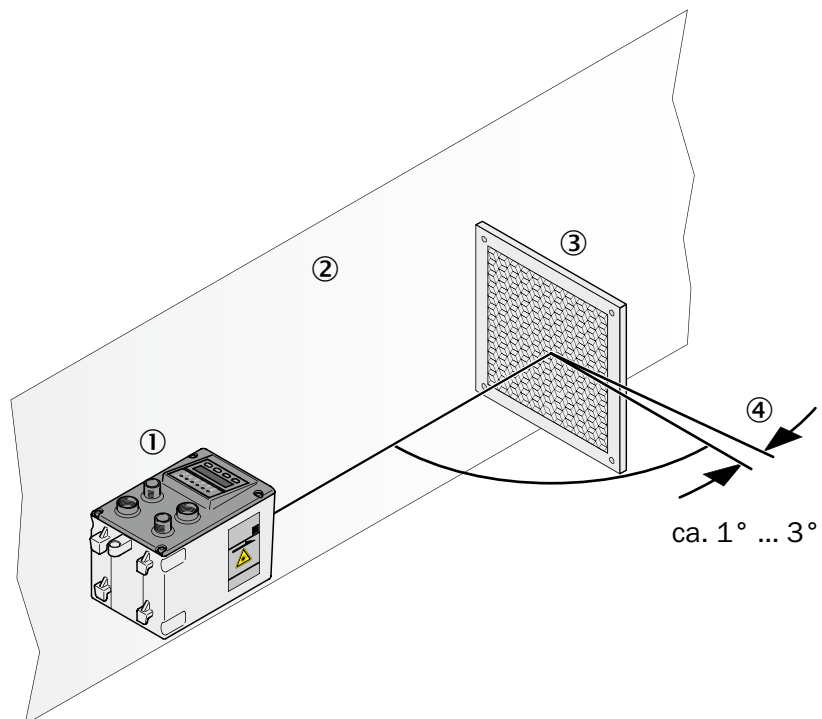

Fig. 8: Installing the reflector on highly reflective surfaces

- 1 Highly reflective surface
- 2 Distance measuring device
- 3 Reflector
- 4 Inclination of approx. 1° to 3°

6.4 Placement of multiple distance measuring devices

Multiple distance measuring devices

If you want to mount several distance measuring devices, you have to consider a minimum distance between the distance measuring devices when mounting them. The minimum distance increases with the maximum scanning range of the distance measuring device.

Formula

$$a \geq 100 \text{ mm} + 0.01 \times s_{\text{max}} [\text{mm}]$$

Example

- Distance measuring device DL100-21xxx01
- Measuring range: 0.15 ... 100 m
- Maximum measuring distance 60 m
- $s_{\text{max}} = 60 \text{ m}$

Calculation

$$a \geq 100 \text{ mm} + 0.01 \times 60000 \text{ mm} \rightarrow 100 \text{ mm} + 600 \text{ mm} \rightarrow 700 \text{ mm}$$

Result

$$a \geq 700 \text{ mm}$$

Light beams in the same direction

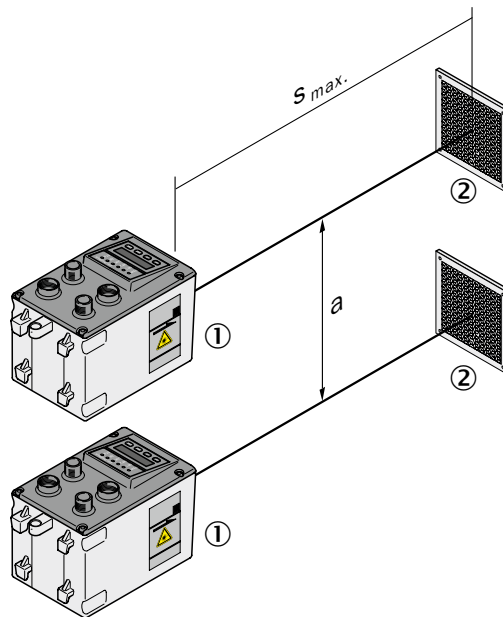

Fig. 9: Placement of two distance measuring devices with light beams in the same light direction.

- 1 Distance measuring device DL100
- 2 Reflector
- a Minimum distance
- s_{max} Maximum scanning range

Mounting

Light beams in the opposite direction

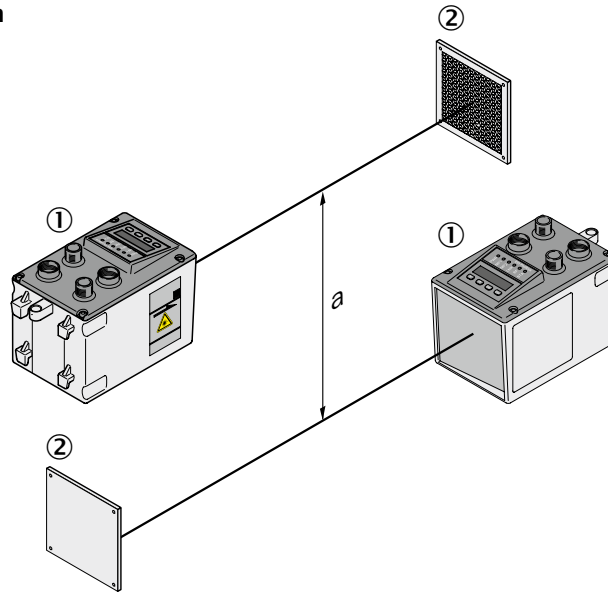

Fig. 10: Placement of two distance measuring devices with light beams in the opposite direction.

- 1 Distance measuring device DL100
- 2 Reflector
- a Minimum distance

6.5 Place the distance measuring device towards the adjacent data transmission photoelectric switch

When mounting with a data transmission photoelectric switch of the ISD300, ISD400-1xxx and ISD400-6xxx series, a beam separation of at least 100 mm must be complied with at all times. The maximum scanning range does not influence the minimum distance. For devices of the ISD400-7xxx (ISD400 Pro) serie other minimum distances apply. Refer to operating instructions “ISD400 Pro”.

Formula

$$a \geq 100 \text{ mm}$$

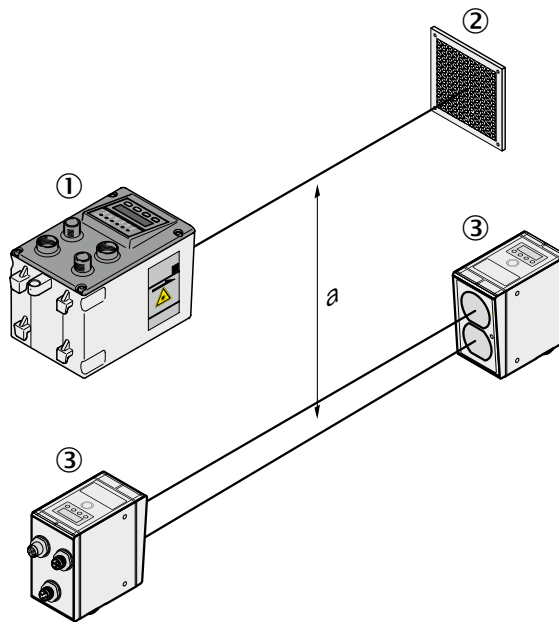

Fig. 11: Placement of the distance measuring device to the data transmission photoelectric switch ISD

- 1 Distance measuring device DL100
- 2 Reflector
- 3 Data transmission photoelectric switch ISD300, ISD400-1xxx or ISD400-6xxx
- a Minimum distance

Mounting

6.6 Align distance measuring device and reflector against each other

1. Move the distance measuring device and reflector close together.
2. Align the distance measuring device so that the light spot of the sensor hits the center of the reflector.
3. Increase the distance between the distance measuring device and the reflector. The sensor light spot must continue to hit the center of the reflector.
4. Check damping. The damping value must not exceed the value in the table.

Damping value

The following table shows the required damping values depending on the distance between the distance measuring device and the reflector. The values in the "rated level" column should not be undercut. When the measured damping value undercuts the value in the column "warning threshold", a warning is issued.

Distance [m]	Rated level [dB]	Warning threshold [dB]
<10	-30	-42
10	-30	-42
20	-42	-54
35	-54	-66
70	-66	-78
150 ¹⁾	-78	-90
300 ²⁾	-90	-102

1) For distance measuring devices with a measurement range of 0.15 ... 200 m or 0.15 ... 300 m

2) For distance measuring devices with a measurement range of 0.15 ... 300 m

Table 4: Damping values

6.7 Mount alignment bracket and distance measuring device

The distance measuring device is mounted by the optional alignment bracket.

→ For dimensions and item number, see page 74, chapter 14.1.

Observe the following items:

- Mounting notes: → see page 23, chapter 6.2.
- The operation must be accessible.

1. Mount alignment bracket across the four oblong holes. The alignment bracket is suitable for mounting to horizontal and vertical levels.

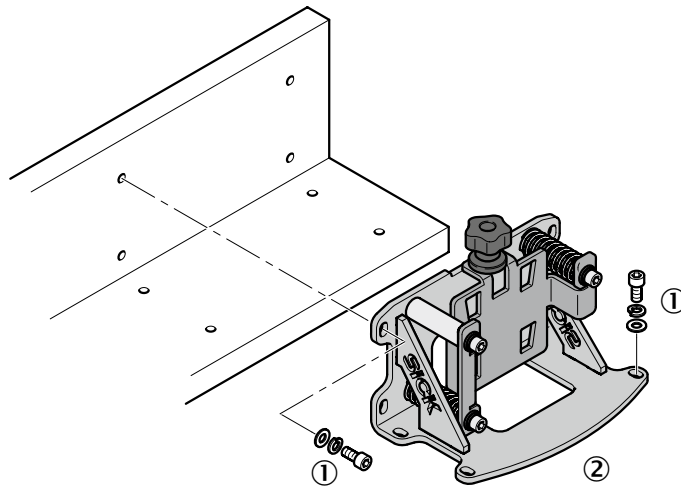

Fig. 12: Mount alignment bracket

- 1 Mounting screw M5
- 2 Alignment bracket

2. Turn out knurled screw from the alignment bracket.
3. Move distance measuring device into the alignment bracket.

Mounting

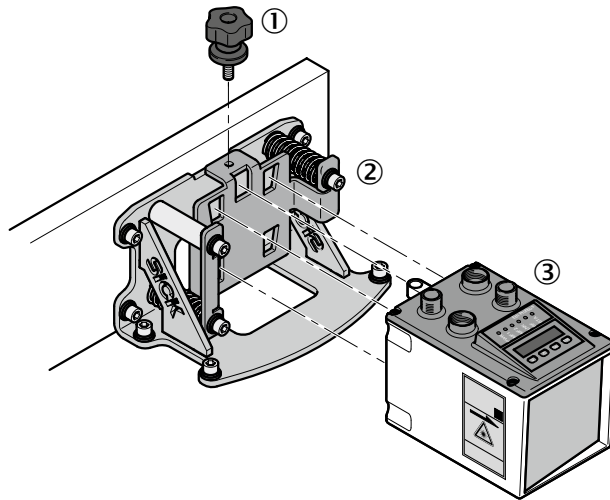

Fig. 13: Mount distance measuring device

- 1 Knurled screw
- 2 Alignment bracket
- 3 Distance measuring device

4. Attach distance measuring device via the knurled screw.

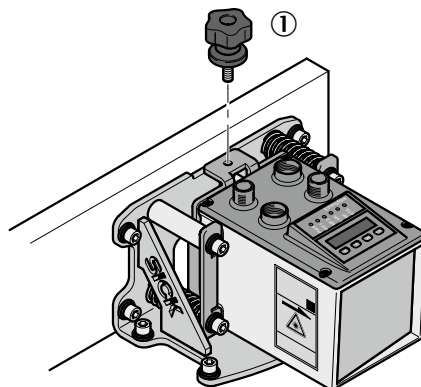

Fig. 14: Attach distance measuring device with the knurled screw

- 1 Knurled screw

6.8 Distance measuring device above alignment bracket

Align the distance measuring device with the alignment bracket according to the following figures. The sensor light spot must hit the center of the reflector.

Alignment in X-direction

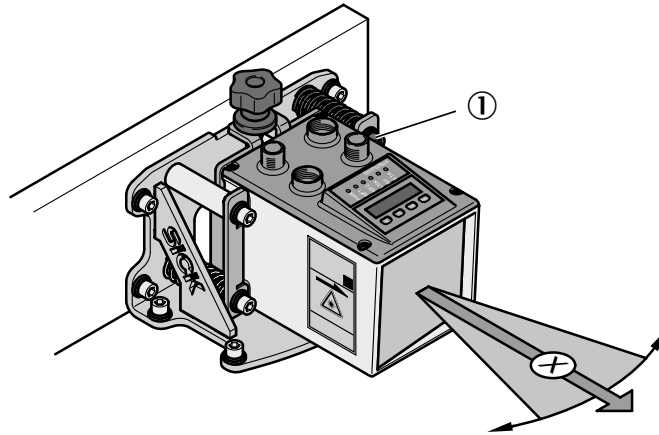

Fig. 15: Align distance measuring device in X-direction using the alignment bracket.

- 1 Set screw to align the distance measuring device in X-direction.

Alignment in Y-direction

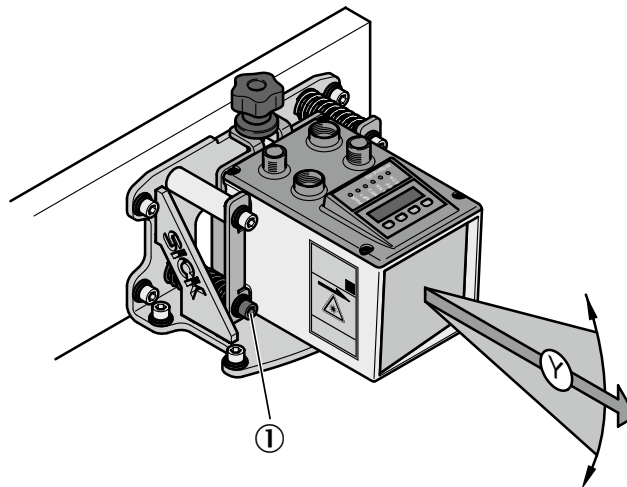

Fig. 16: Align distance measuring device in Y-direction using the alignment bracket.

- 1 Set screw to align the distance measuring device in Y-direction.

Electrical connection

7 Electrical connection

7.1 Safety

Wrong supply voltage

**ATTENTION!****Device damage from wrong supply voltage!**

Incorrect supply voltage may cause damage to the device.

Therefore:

- Only operate the distance measuring device with a protected low voltage and secure electrical insulation of protection class III.
-

Work under voltage

**ATTENTION!****Device damage or unintended operation by work under voltage!**

Working under voltage may cause unintended operation.

Therefore:

- Only perform wiring work in the powered down condition.
 - Line connections must only be established and disconnected with the supply voltage switched off.
-

7.2 Wiring notes

**ATTENTION!****Fault from improper wiring!**

Improper wiring may cause malfunctions in operation.

Therefore:

- Only use shielded cables with twisted pair wires.
 - Observe wiring notes.
-



WARNING!

Risk of damage to the device resulting from a non-grounded supply voltage or equipotential bonding currents!

- A non-grounded supply voltage or potential differences between the supply voltage GND and the distance measuring device housing may result in the device sustaining damage.
- For this reason:
- Only operate with a grounded supply voltage.
- Ensure low-impedance and current-carrying equipotential bonding.



NOTE!

→ Ready-made cables, see page 81, chapter 15.3.

All electrical connections of the distance measuring device DL100 are M12 round plugs.

The connection plugs of the distance measuring device are compatible to the SpeedCon™-quick connections and standard-M12 screw connections.

Protection class IP65 is only achieved with screwed plug connectors or cover caps.

Observe the following notes for wiring:

- A proper and complete shielding concept is required for interference-free function.
- The cable shield must be applied on either side in the control cabinet and the measuring device. The cable shield of the ready-made cables is connected to the knurled nut and thus the measuring device casing.
- Connect the cable shield in the control cabinet with the operating ground on a large cross-section.
- Potential balancing currents through the cable shield must be prevented by suitable measures.
- Do not install the cable in parallel to the other lines, in particular not devices with a high electromagnetic interference, such as frequency converters.

Electrical connection

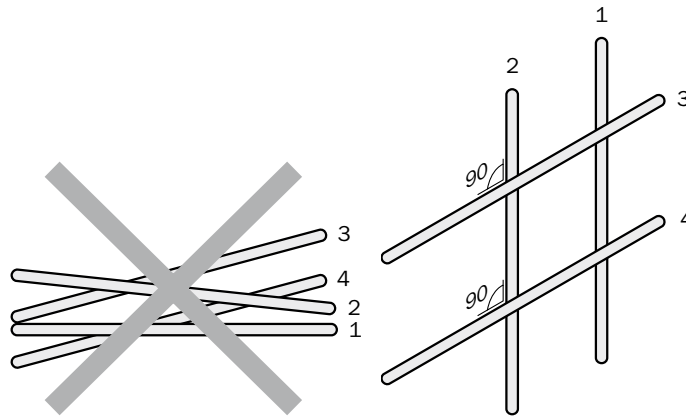

Fig. 17: Cross lines at a right angle

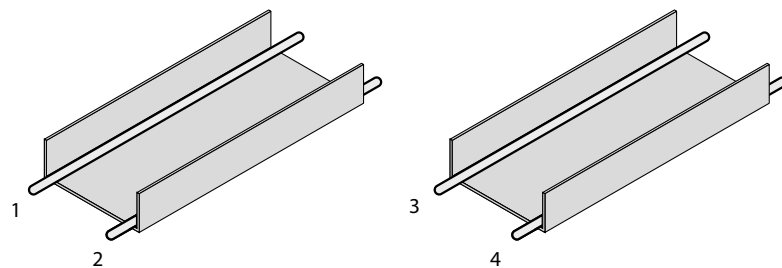

Fig. 18: Ideal placement –
Place lines in different cable channels

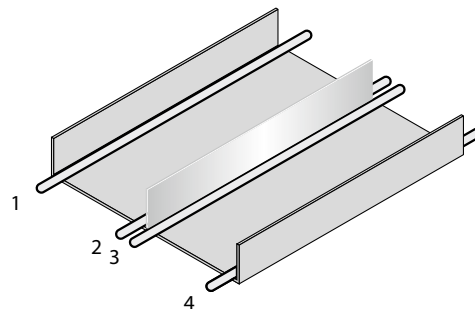

Fig. 19: Alternative installation – separate lines by metallic separation

- 1 Cables very sensitive to interference like analog measuring lines
- 2 Cables sensitive to interference, such as sensor cables, communication signals, bus signals
- 3 Cables that are sources of interference, such as control cables for inductive loads, motor brakes
- 4 Cables that are strong sources of interference, such as frequency converter output cables, supply to welding plants; power cables

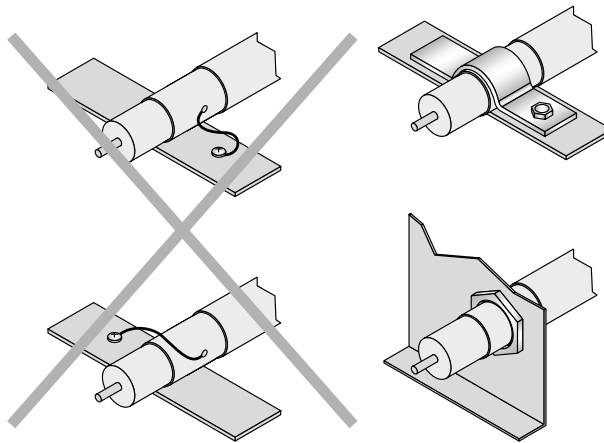

Fig. 20: Briefly connect shield with a large area. Earth both sides.

Electrical connection

7.3 Electrically connect distance measuring device



NOTE!

The distance measuring device has the connection diagram and information on the inputs and outputs on the type sign.

1. Ensure that there is no voltage applied.
2. Connect the measuring device according to the connection diagram.
 - Connection 1 "Pwr/SSI"
 - Connection 2 "Ethernet"

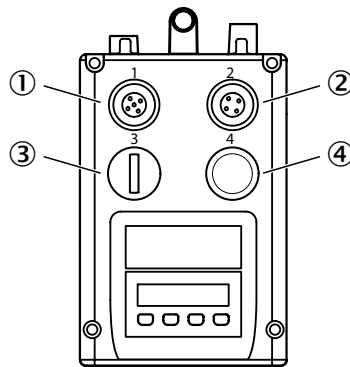

Fig. 21: Position of the electrical connections

- 1 Plug 1: Supply voltage, data transmission SSI
- 2 Plug 2: Ethernet
- 3 Not assigned
- 4 Not assigned

7.4 Connection diagrams

7.4.1 Connection diagram supply voltage

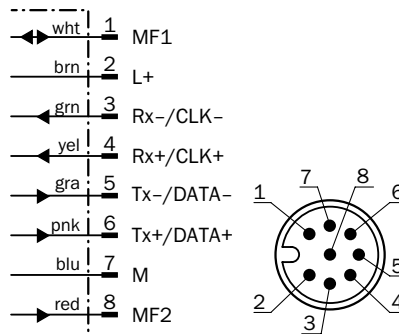

Fig. 22: Connection diagram supply voltage and SSI, plug M12, 8-pin, A-coded

Contact	Marking	Wire color	Description
1	MF1	white	Multifunctional input and output MF1 B-type
2	L+	brown	Supply voltage: +18 ... +30 V DC
3	Rx-/CLK-	green	Cycle signal, inverted
4	Rx+/CLK+	yellow	Cycle signal, not inverted
5	Tx-/Data-	grey	Data signal, inverted
6	Tx+/Data+	pink	Data signal, not inverted
7	M	blue	Supply voltage: 0 V
8	MF2	red	Multifunction output MF2 B-type

Table 5: Description supply voltage plug and SSI

Electrical connection

7.4.2 Connection diagram Ethernet

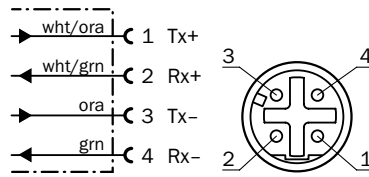

Fig. 23: Connection diagram Ethernet, plug M12, 4-pin, D-coded

Contact	Marking	Wire color	Description
1	Tx+	white/orange	Send data signal, not inverted
2	Rx+	white/green	Receive data signal, not inverted
3	Tx-	orange	Send data signal, inverted
4	Rx-	green	Receive data signal, inverted

Table 6: Description socket Ethernet

8 Operation at the measuring device

Damage to operation



ATTENTION!

Damage to the buttons by incorrect handling!

Incorrect handling of the keys may damage the keys. Operation is made difficult or impossible by this.

Therefore:

- Only operate keys with your fingers or a pointer.
- Do not operate buttons with pointed or hard objects.

8.1 Measured value display

Once the measuring device is supplied with voltage, the display will indicate the current measurement value.

8.2 Choose parameter

Choose a menu, a parameter or an option using the keys **Set** and **▼**. The menu path is indicated in the respective chapter.

→ For the entire menu structure, see page 86, chapter 16.

8.3 Choose option

1. Use the keys **Set** and **▼** to select the desired parameter.
2. Use the key **▼** or **▲** to select the desired option.
3. Perform one of the following steps:
 - Push the key **Set** to save the changes.
 - Push the key **Esc** to cancel the process. The parameter name is displayed again.
4. Perform one of the following steps to return to the measured value display:
 - Push the key **Esc** until the measured value is displayed again.
 - Wait for approx. 2 minutes. The display automatically switches back to measured value display without operation of a key. Any settings made are also saved.

Operation at the measuring device

8.4 Change value

1. Use the keys **Set** and **▼** to select the desired parameter.
2. Push the key **Set**. The current value of the parameter is displayed. The first figure on the left flashes.
3. Push the key **▲** to increase the figure. Push the key **▼** to reduce the figure.
4. Push the key **Set** to save the figure entered. The next figure flashes. Push the key **Esc** to cancel the process.
5. Repeat the steps 3 and 4 until the last figure is saved. The parameter name is displayed.
6. Push the key **Esc** until the measured value is displayed again. Alternatively, you may also wait for a few minutes. The display automatically switches back to measured value display without operation of a key.

8.5 Parameter description

8.5.1 Main menu

The measurement value is displayed by default:

Use the **▼** key to get from the measured value display to the display "Level Bargraph". Use the keys **▼** and **▲** to browse within the main menu.

Display	Description
Measurement value	Measurement value display in mm
Level bargraph	Level display (damping value) as bargraph
Level numeric	Level display (damping value) as numeric value → also see page 28, Table 4.
Temperature	Display of indoor temperature of the measuring device
Operating hours counter	Operating hours display
Warnings	Display of the pending warnings. When a warning is pending, the LED PWR flashes orange. When no warnings are pending, no warnings are displayed. → Also see page 71, chapter 12.2, list of possible warnings.
Error	Display of the pending warnings. When an error is pending, the LED PWR flashes red. When no errors are pending, no errors are displayed. → Also see page 71, chapter 12.3, list of possible errors.

Table 7: Main menu

8.5.2 Menu "SwVers"

The menu "SwVers" shows all information on the software.

You can get to the menu "SwVers" via the menu path:

Main menu → **(Set)** → Menu → **(V)** → SwVers

Push the **(Set)** key for at least 2 seconds to get to the "Menu".

Push the **(Set)** key so that the parameter "App-uC" is displayed.

Use the keys **(V)** and **(^)** to browse within the menu. Push the **(Set)** key to display the respective parameter value.

Parameter	Description
App-uC	Display of the version of the application processor
FPGA	Display of the version of the Field Programmable Gate Array
Com-uC	Indication of the version of the communication processor

Table 8: Menu "SwVers"

8.5.3 Menu "HwVers"

The menu "HwVers" shows all information on the hardware.

You can get to the menu "HwVers" via the menu path:

Main menu → **(Set)** → Menu → **(V)** → SwVers → **(V)** → HwVers

Push the **(Set)** key for at least 2 seconds to get to the "Menu".

Push the **(Set)** key so that the parameter "HwVers" is displayed.

Parameter	Description
HwVers	Version number display

Table 9: Menu "HwVers"

Operation at the measuring device

8.5.4 Menu "SSI"

Use this menu to parameterize the interface "SSI".

You can get to the menu "SSI" via the menu path:

Main menu → **Set** → Menu → **Set** → SSI

Push the **Set** key for at least 2 seconds to get to the "Menu".

Push the **Set** key so that the parameter "Coding" is displayed.

Use the keys **▼** and **▲** to browse within the menu.

Parameter	Description
Coding	<p>Select file format for interface "SSI". → For any other information on the data formats, also see page 68, chapter 10.2.</p> <p>Options</p> <p>Gray-Code</p> <ul style="list-style-type: none"> • Gry24E: Measurement value Bit 1 ... 24, LSB: Error bit • Gry24: Measurement value Bit 0 ... 23 • Gry25: Measurement value Bit 1 ... 24, LSB: Error bit <p>Binary code</p> <ul style="list-style-type: none"> • Bin24E: Measurement value Bit 1 ... 24, LSB: Error bit • Bin24: Measurement value Bit 0 ... 23 • Bin25: Measurement value Bit 1 ... 24, LSB: Error bit <p>Factory setting</p> <ul style="list-style-type: none"> • Gry24E
E-bit (Errorbit)	<p>Select error bit function.</p> <p>The parameter is only displayed if the option "Gry24E" or "Bin24E" was selected for the parameter "Coding".</p> <p>The error bit is set when the option was activated and the case occurs. You may activate (on) or deactivate (off) several options. In case of warning, the error bit is set to "1".</p> <p>Options</p> <ul style="list-style-type: none"> • WrnLsr: Measuring device must be replaced soon because of laser aging. • WrnLev: Level < LevelMin: Required dampening value was undercut. • WrnTemp: Temperature is outside of thresholds. • WrnPIb: Measured value not plausible. • MF1: MF1 active • MF2: MF2 active <p>Factory setting</p> <ul style="list-style-type: none"> • All options are deactivated.

**Menu "SSI"
(continued)**

Parameter	Description
ResDst	<p>Choose resolution for the output value in mm via the digital data interface. The measurement value is multiplied with the resolution. The parameter does not influence the measurement value displayed.</p> <p>Options</p> <ul style="list-style-type: none"> • 0.1 • 0.125 • 1.0 • 10.0 • 100.0 <p>Factory setting</p> <ul style="list-style-type: none"> • 0.1

Table 10: Menu "SSI"

8.5.5 Menu "more"

Use the menu "More" to activate and deactivate the expanded menu view.

You can get to the menu "More" via the menu path:

Main menu → **Set** → Menu → **Set** → SSI → **▼** → more

Push the **Set** key for at least 2 seconds to get to the "Menu".

Push the **Set** key. The currently set option is displayed here.

Options	Description
Yes / No	<p>Active and deactivate expanded menu view.</p> <p>Options</p> <ul style="list-style-type: none"> • Yes • No <p>Factory setting</p> <ul style="list-style-type: none"> • No

Table 11: Menu "more"

8.5.6 Menu "MFx On"

Use this menu to activate and deactivate the multifunction input/output MF1 and the multifunction output MF2.

You can get to the menu "MFx On" via the menu path:

Main menu → **Set** → Menu → **Set** → SSI → **▼** → more → **▼** → MFx On.

Push the **Set** key for at least 2 seconds to get to the "Menu".

Push the **Set** key. The currently set option is displayed here.

Operation at the measuring device

Requirements for the display

Menu "more": Option "Yes".

Options	Description
Enable / Disable	<p>Activate or deactivate multifunction input/output MF1 and multifunction output MF2.</p> <p>Options</p> <ul style="list-style-type: none"> • Enable: Multifunction input/output MF1 and multifunction output MF2 are activated. • Disable: Multifunction input/output MF1 and multifunction output MF2 are deactivated. <p>Factory setting</p> <ul style="list-style-type: none"> • Enable

Table 12: Menu "MFx On"

8.5.7 Menu "MF1"

This menu and the associated submenus can be used to set parameters for the multifunction input/output MF1.

You can get to the menu "MF1" via the menu path:

Main menu → **Set** → Menu → **Set** → SSI → **▼** → more → **▼** → MFx On → **▼** → MF1

Push the **Set** key for at least 2 seconds to get to the "Menu".

Push the **Set** key so that the parameter "ActSta" is displayed.

Use the keys **▼** and **▲** to browse within the menu. Push the **Set** key to display the respective parameter value.

Requirements for the display

- Menu "more": Option "Yes"
- Menu "MFx On": Option "Enable"

Options	Description
ActSta	<p>Select level or flank of the multifunction input/output MF1.</p> <p>Options</p> <ul style="list-style-type: none"> • ActLow: LOW-level at active output (normally closed/NC) or activation of the input at dropping flank • ActHi: HIGH-level at active output (normally open/NO) or activation of the input at rising flank <p>Factory setting</p> <ul style="list-style-type: none"> • ActLow

**Menu "MF1"
(continued)**

Parameter	Description
Functn	<p>Select function for the multifunction input/output. Depending on the selection, the corresponding submenu is displayed.</p> <p>Options</p> <ul style="list-style-type: none"> • Dist: MF1 is used as distance switching output. • Speed: MF1 is used as speed switching output. • Srvice: MF1 is used as service output. • LsrOff: MF1 is used as input to deactivate the laser. • Preset: MF1 is used as input for activation of the preset (overwriting the offset). Offset = Preset value - current measured value. <p>Factory setting</p> <ul style="list-style-type: none"> • Dist
Dist / SpeedSrvice / LsrOff / Preset	<p>Depending on the selection for the parameter "Functn", the corresponding submenu is displayed. For parameter description, see the respective table.</p> <p>No further submenu is displayed for the option "LsrOff". When the multifunction input MF1 is active, the laser is switched off.</p>
Count	<p>Counts the switching events of the multifunction input/output. The counter is reset by deactivation and activation of the distance measuring device.</p>

Table 13: Menu "MF1"

8.5.8 Submenu "MF1 – Dist"

This submenu is used to parameterize the multifunction output MF1 as distance switching output.

You can get to the menu "Dist" via the menu path:

Main menu → **Set** → Menu → **Set** → SSI → **✓** → more → **✓** → MFx On → **✓** → MF1 → **Set** → Actsta → **✓** → Functn → **✓** → Dist

Push the **Set** key for at least 2 seconds to get to the "Menu".

Requirements for the display

- Menu "more": Option "Yes"
- Menu "MFx On": Option "Enable"
- Parameter "Functn": Option "Dist"

Parameter	Description
Limit	Set distance-dependent switching threshold.
Hysteresis	Set Hysteresis for the switching threshold.

Table 14: Submenu "MF1 – Dist"

Operation at the measuring device

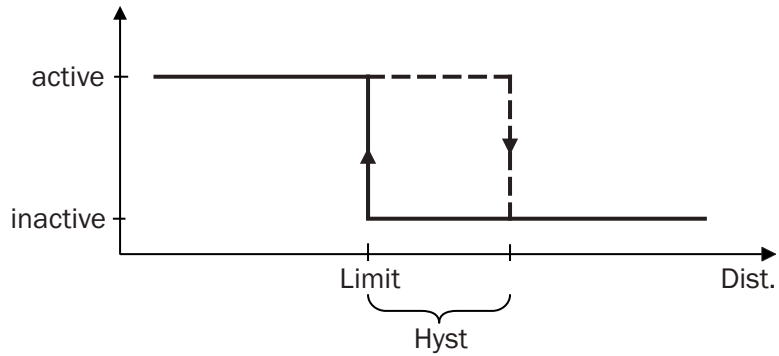

Fig. 24: Displaying the function "Dist."

Limit: Distance-dependent switching threshold

Hyst: Switching threshold hysteresis

Dist: Measured distance

8.5.9 Submenu "MF1 – Speed"

This submenu is used to parameterize the multifunction output MF1 as speed output.

You can get to the menu "Speed" via the menu path:

Main menu → **Set** → Menu → **Set** → SSI → **√** → more → **√** → MFx On → **√** → MF1 → **Set** → Actsta → **√** → Functn → **√** → Speed

Push the **Set** key for at least 2 seconds to get to the "Menu".

Requirements for the display

- Menu "more": Option "Yes"
- Menu "MFx On": Option "Enable"
- Parameter "Functn": Option "Speed"

Parameter	Description
Limit	<p>Set speed for the switching threshold The switching output is activated when the current speed exceeds the set speed. The switching hysteresis is set firmly to $\pm 0.1\text{m/s}$.</p> <p>Adjustment range Range 0.0 ... 9.9 m/s</p> <p>Factory setting</p> <ul style="list-style-type: none"> • 0 [mm]

**Submenu "MF1 – Speed"
(continued)**

Parameter	Description
Sign	<p>Choose the travel direction to be monitored.</p> <p>Options</p> <ul style="list-style-type: none"> • + / -: Once the set speed is exceeded in one direction, the switching output is activated. • +: Once the set speed is exceeded with increasing distance, the switching output is activated. • -: Once the set speed is exceeded with decreasing distance, the switching output is activated. <p>Factory setting</p> <ul style="list-style-type: none"> • + / -

Table 15: Submenu "MF1 – Speed"

8.5.10 Submenu "MF1 – Srvce"

This submenu is used to parameterize the multifunction output MF1 as service output. You may activate (on) or deactivate (off) several options.

You can get to the menu "Srvce" via the menu path:

Main menu → **(Set)** → Menu → **(Set)** → SSI → **(V)** → more → **(V)** → MFx On → **(V)** → MF1 → **(Set)** → Actsta → **(V)** → Functn → **(V)** → Srvce

Push the **(Set)** key for at least 2 seconds to get to the "Menu".

Requirements for the display

- Menu "more": Option "Yes"
- Menu "MFx On": Option "Enable"
- Parameter "Functn": Option "Srvce"

Parameter	Description
WrnLsr	<p>Activating and deactivating warning messages when the measuring device must be replaced soon because the laser ages.</p> <p>Options</p> <ul style="list-style-type: none"> • On • Off <p>Factory setting</p> <ul style="list-style-type: none"> • On
WrnLsr	<p>Activating and deactivating warning messages when the measuring device must be replaced soon because the laser ages.</p> <p>Options</p> <ul style="list-style-type: none"> • On • Off <p>Factory setting</p> <ul style="list-style-type: none"> • On

Operation at the measuring device

Submenu "MF1 – Srvce" (continued)

Parameter	Description
WrnLvl	<p>Activate or deactivate warning messages when the damping value is undercut, e.g. at contamination.</p> <p>Options</p> <ul style="list-style-type: none"> • On • Off <p>Factory setting</p> <ul style="list-style-type: none"> • On
WrnTemp	<p>Activate or deactivate warning message when the inner temperature of the measuring device is outside of the permissible thresholds.</p> <p>Options</p> <ul style="list-style-type: none"> • On • Off <p>Factory setting</p> <ul style="list-style-type: none"> • On
WrnPlb	<p>Activate or deactivate warning when the measurement value is not plausible. Possible reasons may be a incorrect measurements, interruption of the light beam, optical interferences or electrical interferences.</p> <p>Options</p> <ul style="list-style-type: none"> • On • Off <p>Factory setting</p> <ul style="list-style-type: none"> • On
NotRdy	<p>Activate or deactivate warning when the laser is not ready for operation. Possible causes may be hardware faults or the laser being switched off. This warning message is also output during initialization.</p> <p>Options</p> <ul style="list-style-type: none"> • On • Off <p>Factory setting</p> <ul style="list-style-type: none"> • On
Heat	<p>Activate or deactivate warning when the heating is switched on. This parameter is only displayed for measuring devices with the option "Heating".</p> <p>Options</p> <ul style="list-style-type: none"> • On • Off <p>Factory setting</p> <ul style="list-style-type: none"> • On

Table 16: Submenu "MF1 – Srvce"

8.5.11 Submenu "MF1 - Preset" – move to initialization position

The function "Preset" permits automation of initialization of shelf supply devices and other rail-bound vehicles during maintenance, commissioning or exchange.

During initialization, the desired output value is set in a defined position (initialization position) (Preset).

This submenu is used to parameterize the multifunction input MF1 as "Preset function".



NOTE!

When activating the "Preset", the measured value output of the distance measuring device is not available for a short time. We recommend performing the "Preset" in standstill or at very low speeds. The maximum activation time is typically at 10000 cycles.

Main menu → **Set** → Menu → **Set** → SSI → **▼** → more → **▼** → MFx On → **▼** → MF1 → **Set** → Actsta → **▼** → Functn → **▼** → Preset

Push the **Set** key for at least 2 seconds to get to the "Menu".

Requirements for the display

- Menu "more": Option "Yes"
- Menu "MFx On": Option "Enable"
- Parameter "Functn": Option "Preset"

Parameter	Description
sPrset	<p>The preset serves as initialization value. When the multifunction input MF1 is activated, the preset is used.</p> <p>Adjustment range</p> <ul style="list-style-type: none"> • -300000 ... + 300000 <p>Since the display only has six digits, you may only enter negative values up to "-99999" in the display.</p> <p>Factory setting</p> <ul style="list-style-type: none"> • 10

Table 17: Submenu "MF1 – Preset"

Operation at the measuring device

1. Select the function "Preset" for the multifunction input MF1
2. Enter the parameter "Preset" for the desired initialization value.
3. Move the vehicle to the initialization position.
4. Activate the multifunction input MF1, e.g. via a proximity initiator, photoelectric sensor or switch.
5. The output value of the distance measuring device corresponds to the value set for "Preset" at the initialization position.

8.5.12 Menu "MF2"

This menu and the associated submenus can be used to set parameters for the multifunction output MF2.

To get to menu "MF2", use the menu path:

Main menu → **Set** → Menu → **Set** → SSI → **▼** → more → **▼** → MFx On → **▼** → MF1 → **▼** → MF2

Push the **Set** key for at least 2 seconds to get to the "Menu".

Push the **Set** key so that the parameter "ActSta" is displayed.

Use the keys **▼** and **▲** to browse within the menu. Push the **Set** key to display the respective parameter value.

Requirements for the display

- Menu "More": Option "Yes"
- Menu "MFx On": Option "Enable"

Parameter	Description
ActSta	<p>Select multifunction output level MF2.</p> <p>Options</p> <ul style="list-style-type: none"> • ActLow: LOW-level at active output (opener/NC) • ActHi: HIGH-level at active output (closer/NO) <p>Factory setting</p> <ul style="list-style-type: none"> • ActLow
Functn	<p>Select function for the multifunction output. Depending on the selection, the corresponding submenu is displayed.</p> <p>Options</p> <ul style="list-style-type: none"> • Dist • Srvce • Speed <p>Factory setting</p> <ul style="list-style-type: none"> • Dist

Parameter	Description
Dist / Speed / Srvce	Depending on the selection for the parameter "Functn", the corresponding submenu is displayed. For parameter description, see the respective table.
Count	Counts the switching events of the multifunction input/output. The counter is reset by deactivation and activation of the distance measuring device.

Table 18: Menu "MF2"

Submenu "MF2 – Dist"

This submenu corresponds to the submenu "Dist" in the menu "MF1".

→ Also see page 45, Table 14.

Submenu "MF2 – Speed"

This submenu corresponds to the submenu "Speed" in the menu "MF1".

→ Also see page 47, Table 15.

Submenu "MF2 – Srvce"

This submenu corresponds to the submenu "Srvce" in the menu "MF1".

→ Also see page 48, Table 16.

8.5.13 Menu "Offset"

Set an offset via this menu.

You can get to the menu "Offset" via the menu path:

Main menu → **Set** → Menu → **Set** → SSI → **▼** → more → **▼** → MFx On → **▼** → (MF1 → **▼** → MF2 → **▼** →) Offset

Push the **Set** key for at least 2 seconds to get to the "menu".

Push the **Set** key. The currently set offset is displayed here.

Requirements for the display

- Menu "more": Option "Yes"

Value	Description
Offset	<p>Specify offset. The offset is added to the internally determined measurement value. The offset affects all outputs and the display indication.</p> <p>Only positive distances are displayed via the interface "SSI". For negative distances, the value output is "0".</p> <p>When the "Preset" function is activated, the offset is overwritten by triggering of the preset input.</p> <p>Adjustment range</p> <ul style="list-style-type: none"> • -300000 ... +300000 mm <p>Factory setting</p> <ul style="list-style-type: none"> • 0 [mm]

Table 19: Menu "Offset"

Operation at the measuring device

8.5.14 Menu "SpecFu"

Set special functions via this menu.

You can get to the menu "SpecFu" via the menu path:

Main menu → **Set** → Menu → **Set** → SSI → **▼** → more → **▼** → MFx On → **▼** → (MF1 → **▼** → MF2 → **▼** →) Offset → **▼** → SpecFu

Push the **Set** key for at least 2 seconds to get to the "Menu".

Push the **Set** key so that the parameter "AvgDst" is displayed.

Use the keys **▼** and **▲** to browse within the menu.

Requirements for the display

- Menu "more": Option "Yes"

Parameter	Description
AvgDst	<p>Select filter depth for the distance values.</p> <p>Options</p> <ul style="list-style-type: none"> • Medium • Slow • Fast <p>Factory setting</p> <ul style="list-style-type: none"> • Medium <p><i>Note: Medium and Slow use the same averaging depth.</i></p>
AvgSpd	<p>Select filter depth for the speed values.</p> <p>Options</p> <ul style="list-style-type: none"> • Medium • Slow • Fast <p>Factory setting</p> <ul style="list-style-type: none"> • Medium <p><i>Note: Medium and Slow use the same averaging depth.</i></p>

**Menu "SpecFu"
(continued)**

Parameter	Description
ErrRej	<p>Select time for error suppression. During this time, the old measurement value is output. When there still is no valid measurement value after the time selected for the parameter "ErrRej", the value "0" is output.</p> <p>Options</p> <ul style="list-style-type: none"> • 200ms: Error/warning is indicted when the error is present for longer than 200 ms. • 50ms: Error/warning is indicted when the error is present for longer than 50 ms. • Off Error/warning is indicated at once, without delay. <p>Factory setting</p> <ul style="list-style-type: none"> • 200ms
Heat	<p>Requirements for the display</p> <ul style="list-style-type: none"> • Only for versions with heating DL100-xxHxxxx <p>This menu is used to set the temperature at which the heating is to activate. The hysteresis is set firmly to 2 K.</p> <p>Adjustment range</p> <ul style="list-style-type: none"> • -10 ... +40 °C <p>Factory setting</p> <ul style="list-style-type: none"> • -10 °C
Reset	Perform reset → see page 53, chapter 8.6.

Table 20: Menu "SpecFu"

8.6 Perform reset

1. Select the parameter "Reset" in the menu "SpecFu".
→ See page 52, chapter 8.5.14
2. Push the key **Set**.
3. The safety request "Sure?" is displayed.
4. Push the button **Set** to reset the measuring device to the delivery state.
Push the key **Esc** to cancel the process.

Operation via Ethernet (Ethernet interface)

9 Operation via Ethernet (Ethernet interface)

You may parameterize the distance measuring device via the Ethernet interface with the SICK configuration software SOPAS.

**NOTE!**

The configuration program SOPAS can be downloaded from "www.sick.com/Dx100".

9.1 IP-network configuration

IP-network configuration – delivery configuration

The distance measuring device is delivered with the following IP-network configuration:

- Static IP-address
- IP address: 192.168.100.236
- IP network mask: 255.255.255.0
- Standard gateway: 192.168.250.100
- DHCP is off.

Invalid IP address

When the system determines an invalid IP network configuration, the delivery configuration is used instead.

IP address assigned by DHCP server

You may specify that the IP addresses are assigned by a DHCP server.

When address assignment by the DHCP server fails, the distance measuring device uses the last set static IP address. If no static IP address was set yet or if this address is invalid (IP address 0.0.0.0), the delivery configuration is used instead. This process may take a few minutes.

The following causes for failed address assignment by the DHCP server are possible:

- No DHCP server present.
- The DHCP server has an interference.
- The DHCP server was not ready yet when the distance measuring device was switched on.
- The network connection has an interference.

9.2 Ethernet parameter list

9.2.1 Device information

Field "Device information"

Parameter	Description
Device type	Display of the device type. Read/Write access • Read only
Serial number	Display of the device's serial number. Read/Write access • Read only

Table 21: Page "Device information" – field "Device information"

Field "Product code"

Parameter	Description
Product code	Display of the product code. Read/Write access • Read only

Table 22: Page "Device information" – field "Product code"

Field "Software Versions"

Parameter	Description
Application controller	Display of the version of the application processor. Read/Write access • Read only
Communications controller	Indication of the version of the communication processor. Read/Write access • Read only
FPGA	Display of the version of the Field Programmable Gate Array. Read/Write access • Read only

Table 23: Page "Device information" – field "Software version"

Field "Hardware Version"

Parameter	Description
Hardware version	Displaying the hardware version. Read/Write access • Read only

Table 24: Page "Device information" – field "Hardware version"

Operation via Ethernet (Ethernet interface)

9.2.2 User information



NOTE!

Changes on the page "User information only take permanent effect if they are stored via the button "Storage" in the field "Store user input".

Field "Device name"

Parameter	Description
Name	Enter optional device name for device identification. Read/Write access <ul style="list-style-type: none"> • Read and write Factory setting <ul style="list-style-type: none"> • Empty

Table 25: Page "User information" – field "Device name"

Field "User information"

Parameter	Description
User information 1	Enter optional user information. Read/Write access <ul style="list-style-type: none"> • Read and write Factory setting <ul style="list-style-type: none"> • Empty
User information 2	→ See parameter "User information 1".
User information 3	→ See parameter "User information 1".

Table 26: Page "Device information" – field "User information"

Field "Store user information"

Parameter	Description
Storage	You may only enter user information in the user level "Maintenance staff". This requires the password "esick". Read/Write access <ul style="list-style-type: none"> • Write only

Table 27: Page "User information" – field "Store user information"

9.2.3 Measured data

Field "Visualisation of measurement values"

Parameter	Description
X-Scale	Enter X-axis for graphic display of the distance value. Read/Write access • Read and write Unit • s
Y min / Y max	Enter minimum and maximum value for the Y-axis. Read/Write access • Read and write Unit • m
Auto-Scale Y	Click the button "Auto-Scale Y" to adjust the display to the current measurement values. Read/Write access • Read and write Unit • m

Table 28: Page "Measured data" – field "Visualisation of measurement values"

Field "Measurement values"

Parameter	Description
Distance	Measurement value "Distance" after filter, corrections and offset. Read/Write access • Read only Unit • m
Velocity	Measurement value "Speed". Read/Write access • Read only Unit • m/s
Acceleration	Measurement value "Acceleration". Read/Write access • Read only Unit • m/s ²

Table 29: Page "Measured data" – field "Measurement values"

Operation via Ethernet (Ethernet interface)

9.2.4 Diagnostic data

Field	Description
Device state	Display device status: ready for operation, warning(s) active, error active, laser activated, MF1 active and MF2 active. Read/Write access <ul style="list-style-type: none"> • Read only
Device warnings	Display of current warnings: Laser, temperature, level and plausibility. Read/Write access <ul style="list-style-type: none"> • Read only
Device error	Display of current errors: Laser, temperature, level and plausibility. Read/Write access <ul style="list-style-type: none"> • Read only
Level	Display of the current reception level (damping value). Read/Write access <ul style="list-style-type: none"> • Read only
Temperature	Display of current internal device temperature. Read/Write access <ul style="list-style-type: none"> • Read only Unit <ul style="list-style-type: none"> • °C
Operating hours	Display of current operating hours. Read/Write access <ul style="list-style-type: none"> • Read only Unit <ul style="list-style-type: none"> • h

Table 30: Page "Diagnostic data"

9.2.5 Parameter settings

Field "General settings"

Parameter	Description
Distance offset	Specify offset value for the distance measurement value. Read/Write access • Read and write Input value • -300000 ... 300000 Unit • mm Factory setting • 0
Preset	Specify present value for the distance measurement value. Read/Write access • Read and write Input value • -300000 ... 300000 Unit • mm Factory setting • 0

Table 31: Page "Parameter settings" – field "General settings"

Field "Measurement value resolution"

Parameter	Description
Distance resolution	Choose resolution for the output value "Distance". The measurement value is multiplied with the resolution. The parameter does not influence the measurement value displayed. Read/Write access • Read and write Input value • 0: 0.1 / 1: 0.125 / 2: 1.0 / 3: 10.0 / 4: 100.0 Factory setting • 0.1 mm

Table 32: Page "Parameter settings" – field "Measured value resolution"

Operation via Ethernet (Ethernet interface)

Field "SSI configuration"

Parameter	Description
Protocol	<p>Select protocol (file format) for interface "SSI". → For any other information on the data formats, also see page 68, chapter 10.2.</p> <p>Factory setting</p> <ul style="list-style-type: none"> • Gry24E <p>Read/Write access</p> <ul style="list-style-type: none"> • Read and write <p>Input value</p> <ul style="list-style-type: none"> • 0: 24 bit gray + Error (binary) / 1: 24 bit gray / 2: 25 bit gray / 3: 24 bit gray + Error (binary) / 4: 24 bit binary / 5: 25 bit binary <p>Factory setting</p> <ul style="list-style-type: none"> • 24 bit gray + error (binary)
Activate SSI configuration	<ul style="list-style-type: none"> • Use the button "Activate SSI configuration" to activate the selected protocol.

Table 33: Page "Parameter settings" – field "SSI configuration"

Field "Errorbit configuration"

Parameter	Description
Errorbit configuration	<p>Select error bit function.</p> <p>The parameter is only displayed if either the option "24 bit gray + error (binary)" or "24 bit binary + Error (binary)" was selected for the parameter "Protocol".</p> <p>The error bit is set when the option was activated and the case occurs. You may activate or deactivate several options. In case of warning, the error bit is set to "1".</p> <p>Read/Write access</p> <ul style="list-style-type: none"> • Read and write <p>Input value</p> <p>You may activate several warning messages at once.</p> <ul style="list-style-type: none"> • Warning measurement value stability • Warning reception level • Warning laser • Warning temperature • Device not ready for operation • Status heating (for device model with heating) <p>Factory setting</p> <ul style="list-style-type: none"> • All options are deactivated.

Table 34: Page "Parameter settings" – field "Errorbit configuration"

Operation via Ethernet (Ethernet interface)

Field "MF1/MF2 activation"

Parameter	Description
MF activation	<p>Activate and deactivate multifunction input and output MF1 and multifunction output MF2.</p> <p>Read/Write access</p> <ul style="list-style-type: none"> • Read and write <p>Input value</p> <ul style="list-style-type: none"> • 0: Off / 1: On <p>Factory setting</p> <ul style="list-style-type: none"> • On

Table 35: Page "Parameter settings" – field "MF1/MF2 activation"

Field "MF1 function configuration"

Requirements for the display

- Parameter "MF1 activation": Option "Enable"

Parameter	Description
Function	<p>Select function for multifunction input and output MF1.</p> <p>Read/Write access</p> <ul style="list-style-type: none"> • Read and write <p>Input value</p> <ul style="list-style-type: none"> • 0: Distance: → See page 62, field "MF1, Threshold distance underflow" • 1: Velocity: → See page 62 field "MF1, Threshold velocity exceeded" • 2: Service: → See page 63 field "MF1, Service configuration" • 3: Laser • 4: Preset <p>Factory setting</p> <ul style="list-style-type: none"> • Distance
Active state	<p>Select level for the active condition for the multifunction input and output MF1.</p> <p>Read/Write access</p> <ul style="list-style-type: none"> • Read and write <p>Input value</p> <ul style="list-style-type: none"> • 0: High / 1: Low <p>Factory setting</p> <ul style="list-style-type: none"> • Low

Table 36: Page "Parameter settings" – field "MF1 function configuration"

Operation via Ethernet (Ethernet interface)

Field "MF1, Threshold distance underflow"

Requirements for the display

- Parameter "MF1 activation": Option "Enable"
- Parameter "Function": Option "Distance"

Parameter	Description
Threshold distance	Enter switching threshold for the multifunction output MF1. Read/Write access <ul style="list-style-type: none"> • Read and write Input value <ul style="list-style-type: none"> • -300000 ... 300000 Unit <ul style="list-style-type: none"> • mm Factory setting <ul style="list-style-type: none"> • 1990
Hysteresis distance	Enter hysteresis for switching threshold for the multifunction output MF1. Read/Write access <ul style="list-style-type: none"> • Read and write Input value <ul style="list-style-type: none"> • 1 ... 300000 Unit <ul style="list-style-type: none"> • mm Factory setting <ul style="list-style-type: none"> • 10

Table 37: Page "Parameter settings" – field "MF1, Threshold distance underflow"

Field "MF1, Threshold velocity exceeded"

Requirements for the display

- Parameter "MF1 activation": Option "Enable"
- Parameter "Function": Option "Velocity"

Parameter	Description
Threshold velocity	Enter switching threshold for the multifunction output MF1. Read/Write access <ul style="list-style-type: none"> • Read and write Input value <ul style="list-style-type: none"> • 0 ... 15000 Unit <ul style="list-style-type: none"> • mm/s Factory setting <ul style="list-style-type: none"> • 5000

Operation via Ethernet (Ethernet interface)

Field "MF1, Threshold velocity exceeded", (continued)

Parameter	Description
Distance change	<p>Choose the travel direction to be monitored.</p> <p>Read/Write access</p> <ul style="list-style-type: none"> • Read and write <p>Input value</p> <ul style="list-style-type: none"> • 0: Increasing (positive values) / 1: Decreasing (negative values) / 2: Increasing and decreasing <p>Factory setting</p> <ul style="list-style-type: none"> • increasing and decreasing

Table 38: Page "Parameter settings" – field "MF1, Threshold velocity exceeded"

Field "MF1, Service configuration"

Requirements for the display

- Parameter "MF1 activation": Option "Enable"
- Parameter "Function": Option "Service"

Parameter	Description
Configuration device monitoring	<p>Activating and deactivating warning messages. When the event for the warning message occurs, the multifunction switching output MF1 switches.</p> <p>Read/Write access</p> <ul style="list-style-type: none"> • Read and write <p>Input value</p> <p>You may activate several warning messages at once.</p> <ul style="list-style-type: none"> • Warning measurement stability • Warning level • Warning laser • Warning temperature • Device not ready • Heater state (for device model with heating) <p>Factory setting</p> <ul style="list-style-type: none"> • The warning messages "Measurement stability", "Level", "Laser", "Temperature" and "Device not ready" are activated. The message "Heater state" is deactivated.

Table 39: Page "Parameter settings" – field "MF1, Service configuration"

Operation via Ethernet (Ethernet interface)

Field "MF2 function configuration"

Requirements for the display

- Parameter "MF2 activation": Option "Enable"

Parameter	Description
Function	Select function for the multifunction MF2 output. Read/Write access • Read and write Input value • 0: Distance / 1: Speed / 2: Service Factory setting • Service
Active state	Select level for the active condition for the multifunction output MF2. Read/Write access • Read and write Input value • 0: High / 1: Low Factory setting • Low

Table 40: Page "Parameter settings" – field "MF2 function configuration"

Field "MF2, Threshold distance underflow"

→ See page 62, Table 37, "MF1, Threshold distance underflow".

Field "MF2, Threshold velocity exceeded"

→ See page 63, Table 38, "MF1, Threshold velocity exceeded".

Field "MF2, Service configuration"

→ See page 63, Table 39, "MF1, Service configuration".

Field "Number of MF activation"

Parameter	Description
MF1	Counts the switching events of the multifunction input and output MF1. You may reset the counters via the button "Reset MF1". Read/Write access • Read and write Input value • -2147483648 ... 2147483647
M2	Counts the switching events of the multifunction output MF2. You may reset the counters via the button "Reset MF2". Read/Write access • Read and write Input value • -2147483648 ... 2147483647

Table 41: Page "Parameter settings" – field "Number of MF activation"

Operation via Ethernet (Ethernet interface)

Field "Advanced device function"

Parameter	Description
Average filter distance	Select filter depth for the distance values. Read/Write access • Read and write Input value • 0: Fast / 1: Medium / 2: Slow Factory setting • Medium
Average filter velocity	Select filter depth for the speed values. Read/Write access • Read and write Input value • 0: Fast / 1: Medium / 2: Slow Factory setting • Medium
Error rejection	Select time for error suppression. If there is an error, the measurement value is indicated as "0". Read/Write access • Read and write Input value • 0: Off / 1: 50 ms / 2: 200 ms Factory setting • 200 ms

Table 42: Page "Parameter settings" – field "Advanced device function"

Field "Heater"

Requirements for the display

- Devices with the option "Heating" (DL100-xxHxxxx)

Parameter	Description
Heater threshold	Enter power up threshold for heating. Read/Write access • Read and write Input value • -10 ... +40 Unit • °C Factory setting • -10

Table 43: Page "Parameter settings" – field "Heater"

Operation via Ethernet (Ethernet interface)

Field "Store parameter"

Parameter	Description
Storage	<p>Parameter changes only enter into permanent effect if they are saved via the button "Save".</p> <p>Read/Write access</p> <ul style="list-style-type: none"> • Write only

Table 44: Page "Parameter settings" – field "Store parameters"

Field "Set parameters to default values"

Parameter	Description
Parameter reset	<p>Click the button "Parameter Reset" to reset the parameters to factory settings.</p> <p>Read/Write access</p> <ul style="list-style-type: none"> • Write only

Table 45: Page "Parameter settings" – field "Set parameters to default values"

9.2.6 Methods

Field	Description
Device reboot	<ul style="list-style-type: none"> • Click the button "Reboot" to cause the device to restart. <p>Read/Write access</p> <ul style="list-style-type: none"> • Write only
Laser control	<p>Switch the laser on and off as follows:</p> <ul style="list-style-type: none"> • Use the selection button to select the desired option. • Click the button to perform the option. <p>Read/Write access</p> <ul style="list-style-type: none"> • Write only <p>Input value</p> <ul style="list-style-type: none"> • 0: Off / 1: On <p>Factory setting</p> <ul style="list-style-type: none"> • Off
Heating control	<p>Control the heating as follows:</p> <ul style="list-style-type: none"> • Use the selection button to select the desired option. • Click the button to perform the option. <p>Read/Write access</p> <ul style="list-style-type: none"> • Write only <p>Input value</p> <ul style="list-style-type: none"> • 0: Off / 1: On / 2: Auto <p>Factory setting</p> <ul style="list-style-type: none"> • Auto

Table 46: Page "Methods"

10 Interface "SSI"

10.1 Basics

The interface "SSI" (Synchronous serial interface) permits absolute information on the position by serial data transfer. Cycle and data are transferred via the interface.

Data is transmitted on request of the control. Cycle time and transmission speed can be set within wide thresholds. For this, a cycle sequence is put on the DME reception input by the connected control unit. With each provide cycle flank, a data bit is pushed onto the transition line distance measuring device, starting with the highest bit. This starts with the highest bit. Between two cycle sequences, there is a cycle break of at least 30 μ s. The bit cycle is between 70 kHz and 500 kHz and depends on the line length.

Transfer rate

Line length [m]	Transfer rate [kBaud]
< 25	< 500
< 50	< 400
< 100	< 300
< 200	< 200
< 400	< 100

Table 47: Transfer rate depending on line length

Impulse diagram

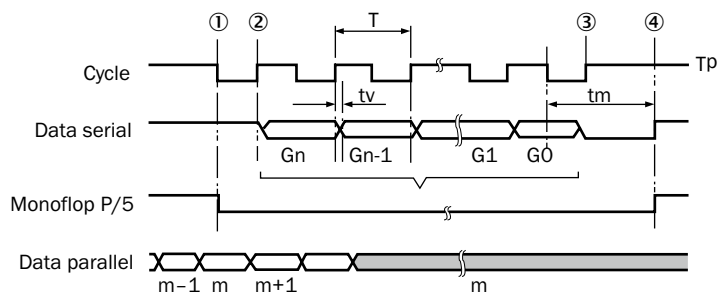

Fig. 25: Impulse diagram for data transmission

G_n Highest-value bit in gray code

G_0 Lowest-value bit in gray code

m Stored parallel information

t_m Mono flop time 15 μ s ... 25 μ s

t_v Delay time: first cycle max. 540 ns, all other cycles max. 360 ns

T Period duration of a cycle signal

T_p Cycle pause

Interface "SSI"

10.2 SSI protocol (data format)

Data formats

Gry24E and Bin24E: 24 data bit gray code/binary code + 1 error bit binary (LSB)

MSB																								LSB
Bit	Bit	Bit	Bit	Bit	Bit	Bit	Bit	Bit	Bit	Bit	Bit	Bit	Bit	Bit	Bit	Bit	Bit	Bit	Bit	Bit	Bit	Bit	Bit	Error binary
24	23	22	21	20	19	18	17	16	15	14	13	12	11	10	9	8	7	6	5	4	3	2	1	

Gry24 and Bin24: 24 data bit gray code/binary code

MSB																								LSB
Bit	Bit	Bit	Bit	Bit	Bit	Bit	Bit	Bit	Bit	Bit	Bit	Bit	Bit	Bit	Bit	Bit	Bit	Bit	Bit	Bit	Bit	Bit	Bit	Bit
24	23	22	21	20	19	18	17	16	15	14	13	12	11	10	9	8	7	6	5	4	3	2	1	

Gry25 and Bin25: 25 data bit gray code/binary code

MSB																									LSB
Bit	Bit	Bit	Bit	Bit	Bit	Bit	Bit	Bit	Bit	Bit	Bit	Bit	Bit	Bit	Bit	Bit	Bit	Bit	Bit	Bit	Bit	Bit	Bit	Bit	Bit
24	23	22	21	20	19	18	17	16	15	14	13	12	11	10	9	8	7	6	5	4	3	2	1	0	

Table 48: Data formats

11 Cleaning and maintenance

11.1 Cleaning



ATTENTION!

Damage to the device from improper cleaning!

Improper cleaning may cause damage to the device.

Therefore:

- Do not use any cleaning agents with aggressive contents.
- Do not use any pointed objects for cleaning.

Clean the front screens with a lint-free cloth and plastic cleaning agent at regular intervals.

The cleaning interval mainly depends on the ambient conditions.

11.2 Maintenance

The distance measuring device DL100 requires the following maintenance work at regular intervals:

Interval	Maintenance work	To be performed by
Cleaning intervals depending on ambience conditions and climate	Cleaning housing	Skilled person
Every 6 months	Check screw and plug connections at regular intervals.	Skilled person

Table 49: Maintenance plan

Troubleshooting

12 Troubleshooting

The following table describes possible interferences and measures for removal.

Contact the manufacturer for interferences that cannot be removed based on the following description. You can find your local office on the reverse.

General interferences, warnings and errors

The distance measuring device differentiates between general interferences, warnings and errors. General interferences are not displayed. When a warning is pending, the LED **PWR** flashes orange. A measurement value is output. When an error is pending, the LED **PWR** flashes red. The measurement value "0" is output.

12.1 LED status indicators

Display	Possible causes	Troubleshooting
The display shows the value "0000".	The measuring device's light spot does not hit the reflector.	Correct alignment between measuring device and reflector.
	The obstacle is in the light path.	Remove obstacle from the light path.
	Distance between distance measuring device and reflector exceeds the maximum scanning range indicated in the technical data. → See page 76, chapter 14.4.	<ul style="list-style-type: none"> • Decrease the distance between the distance measuring device and the reflector. • Select a distance measuring device with a larger maximum scanning range.
LED PWR is not lit. Display is lit.	Measuring device defective.	Send in device for repair.
LED PWR flashes orange.	A warning is pending.	→ For possible causes and their removal, see page 71, chapter 12.2.
LED PWR flashes red.	An error is pending.	→ For possible causes and their removal, see page 71, chapter 12.3.
LED BUS is not lit.	No time signal	<ul style="list-style-type: none"> • Check wiring. • Check clock-pulse generator.

Table 50: LED status indicators

12.2 Warning messages

Display	Meaning / possible causes	Troubleshooting
NoWrn	No warnings	–
wPIb	Measured value not plausible. Light path between measuring device and reflector interrupted.	Observe light spot on the reflector. The light spot must not move from the reflector. If required, re-align measuring device and reflector or use a larger reflector. → For alignment and mounting, see page 23, chapter 6.
	Optical interferences	<ul style="list-style-type: none"> Remove optical interferences. Re-align distance measuring device and reflector. → For alignment and mounting, see page 23, chapter 6.
wLaser	The measurement laser is still operational but at the end of its service life.	Keep replacement device ready.
wLevel	Current damping value is below the recommended damping value. The recommended damping value depends on the distance between measuring device and reflector. → For recommended damping values, see page 28, Table 4.	<ul style="list-style-type: none"> Clean external lens surfaces like the reflector and the lens. Decrease the distance between the measuring device and the reflector. Use a distance measuring device with a higher range. → See page 75, chapter 14.2
wTemp	Internal device temperature is close to the permissible range. → For the permissible ambient temperature, see page 77, chapter 14.9.	<ul style="list-style-type: none"> Check ambience temperature, improve ventilation if applicable. Shield against radiation heat, e.g. share the measuring device in case of direct solar irradiation. Use device with heating at low ambient temperatures. Use cooling housings for high ambient temperatures.

Table 51: Warning messages

12.3 Error messages

Display	Meaning / possible causes	Troubleshooting
NoErr	No error	–
ePIb	Measured value not plausible. Light path between measuring device and reflector interrupted.	Observe light spot on the reflector. The light spot must not move from the reflector. If required, re-align measuring device and reflector or use a larger reflector. → For alignment and mounting, see page 23, chapter 6.
	Optical interferences	<ul style="list-style-type: none"> Remove optical interferences. Re-align distance measuring device and reflector. → For alignment and mounting, see page 23, chapter 6.
eLaser	The service life of a measurement laser is exceeded.	Interchange measuring device.

Repair

Display	Meaning / possible causes	Troubleshooting
eLevel	Current damping value is below the warning threshold. The warning threshold depends on the distance between measuring device and reflector. → For recommended damping values, see page 28, Table 4.	<ul style="list-style-type: none"> • Clean external lens surfaces like the reflector and the lens. • Decrease the distance between the measuring device and the reflector. • Use a distance measuring device with a higher range. → See page 75, chapter 14.2
eTemp	The internal device temperature is outside of the permissible range. → For the permissible ambient temperature, see page 77, chapter 14.9.	<ul style="list-style-type: none"> • Check ambience temperature, improve ventilation if applicable. • Shield against radiation heat, e.g. shade the measuring device in case of direct solar irradiation. • Use device with heating at low ambient temperatures. • Use cooling housings for high ambient temperatures.

Table 52: Error messages

12.4 Return

For efficient processing and quick determination of causes, include the following in your return:

- Information on a contact
- A description of the application
- A description of the error that occurred

12.5 Disposal

Observe the following items for disposal:

- The distance measuring device must not be disposed of in the household waste.
- Dispose of the distance measuring device according to the respective country-specific provisions.

13 Repair

Repairs must only be performed by the manufacturer. The manufacturer's warranty will lapse in case of interruptions and changes to the device.

14 Technical data



NOTE!

You may download, save and print the online datasheet with technical data, dimensions and connection diagrams for your distance measuring device online at "www.sick.com/Dx100".

Technical data

14.1 Dimensions

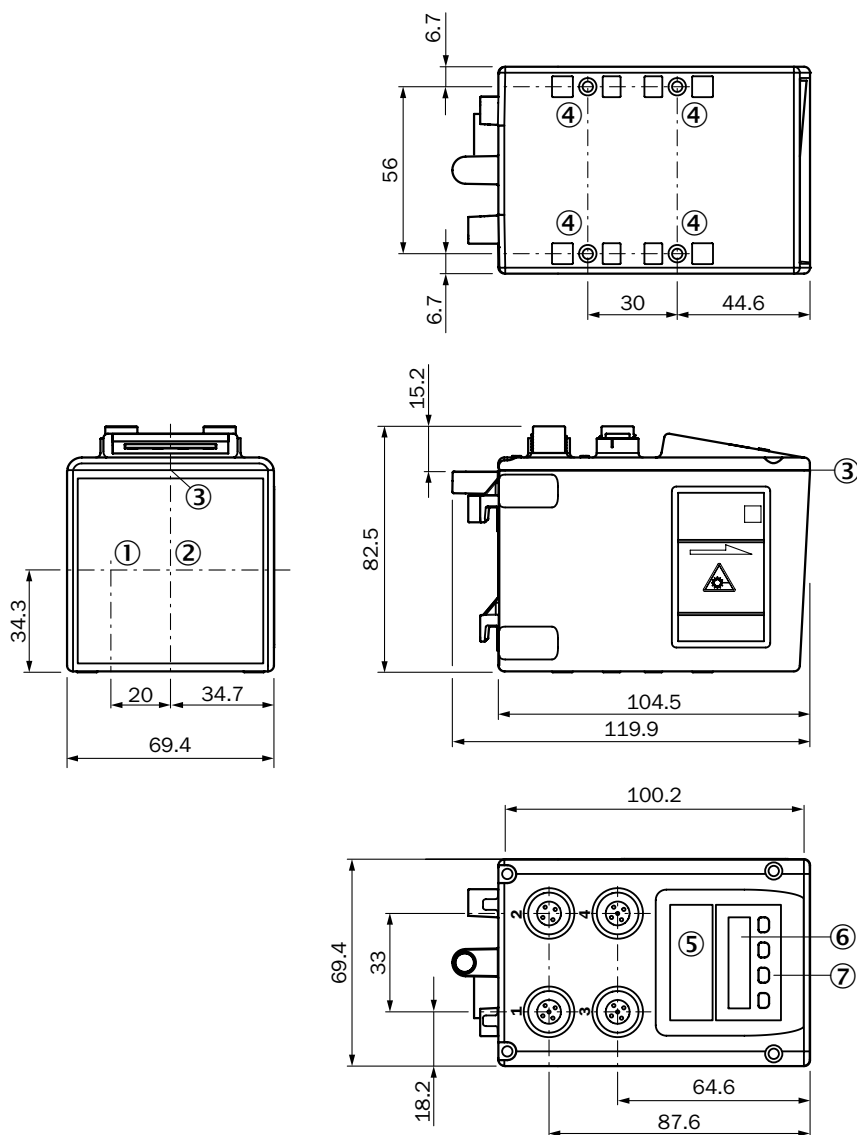

All dimensions in mm

Fig. 26: Dimensions distance measuring device DL100

- 1 Optical axis sender
- 2 Optical axis receiver
- 3 Device zero point
- 4 Threaded mounting hole M5
- 5 LED "Status"
- 6 Display
- 7 Operating elements

14.2 Device selection for the SSI interface

Ambiance temperature	Current consumption at 24 V DC	Measuring range	Accuracy	Operating mode	Repeat-ability ¹	Dead time	Order no.	Type code
[°C]	[mA]	[m]	[mm]			[ms]		
-20 ... +55 -20 ... +75 (with TPCC cooling case 6048328) ²⁾	<250	0.15 ... 60	± 3.0	Fast/Medium	1.5	10	1059957	DL100-11AA2101
				Slow	0.75	30		
		0.15 ... 130	± 4.0	Fast/Medium	2.0	10	1059963	DL100-12AA2101
				Slow	1.0	30		
		0.15 ... 220	± 5.0	Fast/Medium	2.5	10	1059969	DL100-13AA2101
				Slow	1.25	30		
-40 ... +55 (with integrated heating) -40 ... +75 with TPCC cooling case 6048328)	<1000	0.15 ... 60	± 3.0	Fast/Medium	1.5	10	1059958	DL100-11HA2101
				Slow	0.75	30		
		0.15 ... 130	± 4.0	Fast/Medium	2.0	10	1059964	DL100-12HA2101
				Slow	1.0	30		
		0.15 ... 220	± 5.0	Fast/Medium	2.5	10	1059970	DL100-13HA2101
				Slow	1.25	30		

1) Statistic error 1 σ , in function of operating mode

2) For temperatures below -10 °C, a start-up time of typically 7 minutes is required.

Table 53: Device selection



NOTE!

→ For additional information about the variants of other interfaces, please see “www.sick.com/Dx100”.

14.3 Laser/optics

Light source	Laser diode, red light
Laser protection class	2 pursuant to EN 60825-1 /CDRH
CW modulation	± 0.85 Po sine-shape modulated
Maximum output	≤ 1.9 mW
Pulse duration	6.8 ns
Wave length	655 nm
Frequency	≥ 90 MHz
Light spot dimensions	Typical 5 mm + (2 mm x distance [m])
Average service life	Typically 100 000 h at +25 °C

Table 54: Laser/Optics

Technical data

14.4 Performance

Measurement ranges	<ul style="list-style-type: none"> DL100-11XXXXXX: 0.15 m ... 60 m DL100-12XXXXXX: 0.15 m ... 130 m DL100-13XXXXXX: 0.15 m ... 220 m
Measuring accuracy	See type specific data → See page 75, chapter 14.2
Repeatability	See type specific data → See page 75, chapter 14.2
Initialization time	<ul style="list-style-type: none"> Typical 1.5 s After reflector loss: < 40 ms
Reaction time/dead time	See type specific data → See page 75, chapter 14.2
Resolution	Adjustable: 0.1 mm / 0.125 mm / 1.0 mm / 10 mm / 100 mm
Output rate	Synchronous to PLC request

Table 55: Performance data

14.5 Supply

Supply voltage V_s	18 V DC ... 30 V DC
Current consumption	<ul style="list-style-type: none"> Without heating: < 250 mA at 24 V DC With heating : < 1,000 mA at 24 V DC
Residual ripple	< 5 V_{ss} within the permissible supply voltage V_s

Table 56: Supply

14.6 Inputs

Inputs	Multifunction input MF1, adjustable <ul style="list-style-type: none"> Hi > 12 V Lo < 3 V → See page 45, Table 13 and page 51, Table 18 parameter "ActStat".
Protective circuit	No, not reverse polarity protected

Table 57: Inputs

14.7 Outputs

Outputs	Multifunction outputs MF1 and MF2, type: B (push/pull), adjustable <ul style="list-style-type: none"> Hi > UV – 3 V Lo < 2 V → See page 45, Table 13 and page 51, Table 18 parameter "ActStat".
Maximum output current	Max. 100 mA

Output load	<ul style="list-style-type: none"> • Capacity: 100 nF • Inductive 20 mH
-------------	---

Table 58: Outputs

14.8 Interfaces

SSI	Process data interface
Baudrate SSI	Depending on length of cable
Ethernet	Configuration interface

Table 59: Interfaces

14.9 Ambient conditions

Protection class	III Suitable for operation in PELV systems (Protective Extra Low Voltage - safety extra-low voltage) with secure separation.
Electromagnetic compatibility 1)	EN 61000-6-2, EN 55011, category A
Ambient temperature	See type-specific data
Storage temperature range	-40 °C ... +75 °C
Enclosure rating	IP65
Air pressure influence	0.3 ppm/hPa
Temperature influence	1 ppm/K
Temperature drift	Typical 0.1 mm/K
Maximum movement speed	10 m/s
Maximum acceleration change	10 m/s ²
Vibration resistance (sine)	EN60068-2-6
Noise	EN60068-2-64
Shock resistance	EN 60086-2-27

1) When used in the household area, the device may cause interferences.

Table 60: Ambient conditions

Technical data

14.10 Constructive setup

Dimensions	→ See page 74, chapter 14.1.
Weight	<ul style="list-style-type: none"> • Distance measuring device 800 g • Alignment bracket (optional): 800 g
Materials	<ul style="list-style-type: none"> • Casing: Cast aluminum GD-ALSi12Cu1 (3.2982.05) • Front screen: PMMA
Connections	M12, SpeedCon™
Display	<ul style="list-style-type: none"> • 6 points with a 5 x 7 point matrix • Overflow is displayed with the maximum value that can be displayed, -99999 or 999999.

Table 61: Constructive setup

15 Accessories

15.1 Reflectors and reflective tape

15.1.1 Reflectors

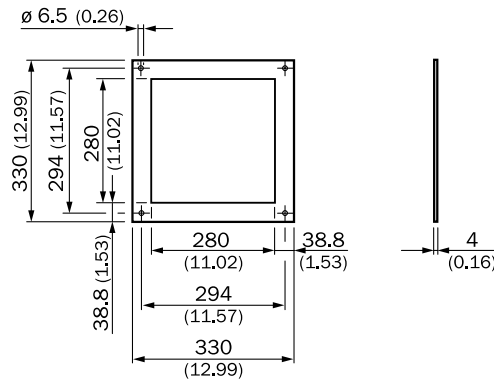

All dimensions in mm (inch)

Fig. 27: Reflector 0.3 x 0.3 m² Diamond Grade, mounted

Description	Reflector 0.3 x 0.3 m ² Diamond Grade, mounted on base plate ALMG3
Type	PL240DG
Part no.	1017910

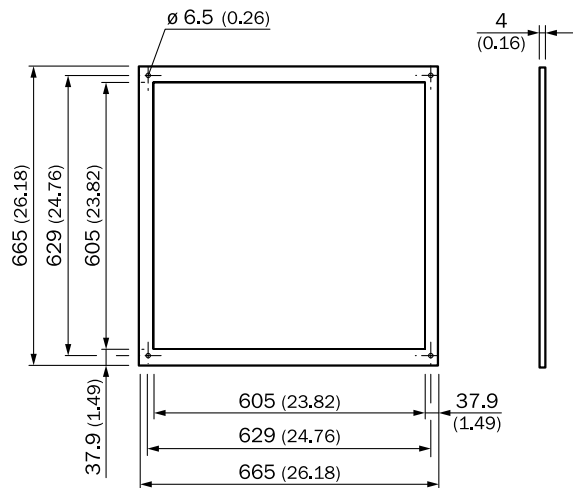

All dimensions in mm (inch)

Fig. 28: Reflector 0.6 x 0.6 m² Diamond Grade, mounted

Description	Reflector 0.6 x 0.6 m ² Diamond Grade, mounted on base plate ALMG3
Type	PL560DG
Part no.	1016806

Accessories

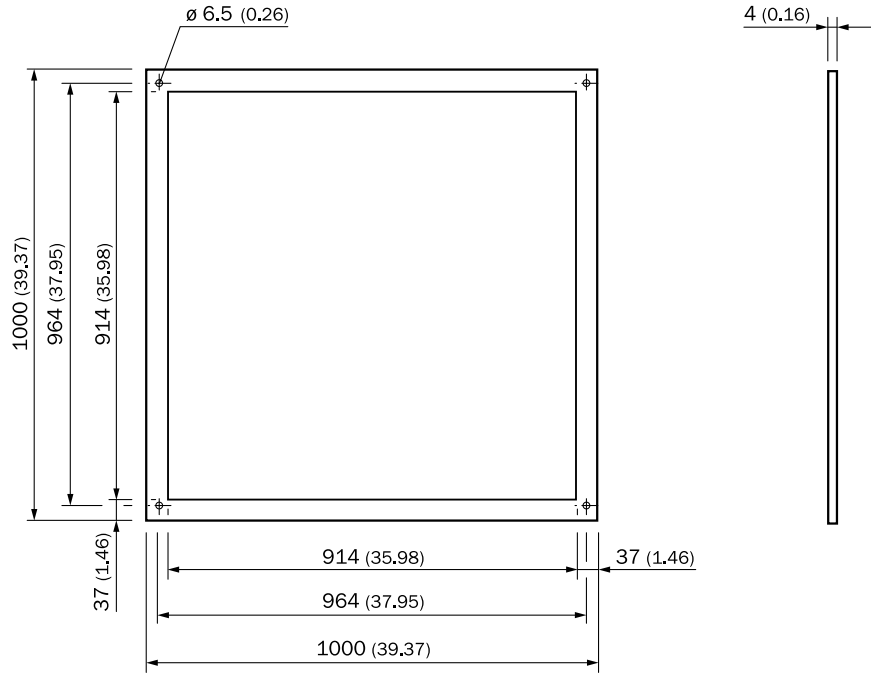

All dimensions in mm (inch)

Fig. 29: Reflector 1.0 x 1.0 m² Diamond Grade, mounted

Description	Reflector 1.0 x 1.0 m ² Diamond Grade, mounted on base plate ALMG3
Type	PL880DG
Part no.	1018975

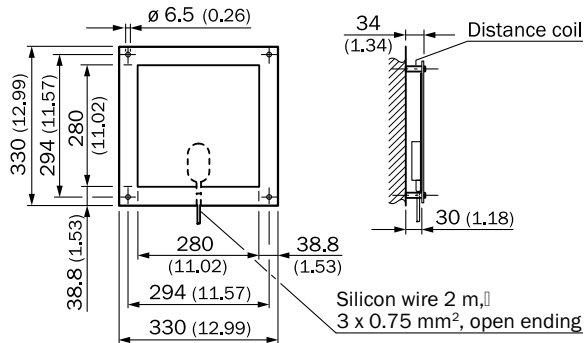

All dimensions in mm (inch)

Fig. 30: Reflector 0.3 x 0.3 m² Diamond Grade, mounted, including heating

Description	Reflector 0.3 x 0.3 m ² Diamond Grade, mounted, on base plate ALMG3, including controlled heating +20 °C, 230 V AC, 200 W, IP 64
Type	PL240DG-H
Part no.	1022926

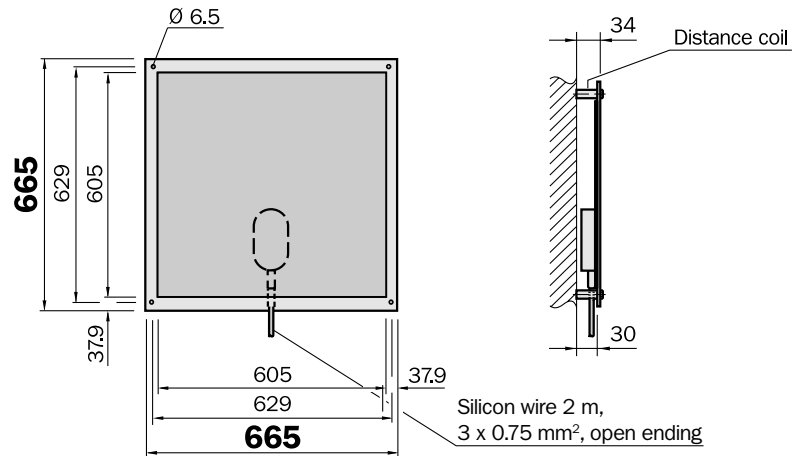

Fig. 31: Reflector 0.6 x 0.6 m² Diamond Grade, mounted, including heating

Description	Reflector 0.6 x 0.6 m ² Diamond Grade, mounted, on base plate ALMG3, including controlled heating +20 °C, 230 V AC, 200 W, IP 64
Type	PL560DG-H
Part no.	1023888

15.1.2 Reflective tape



Fig. 32: "Diamond Grade" reflective tape

Description	"Diamond Grade" reflective tape, size customizable
Type	REF-DG-
Part no.	4019634
Description	"Diamond Grade" reflective tape, curve 749 x 914 mm ²
Type	REF-DG-
Part no.	5320565

Accessories

15.2 Connection systems

15.2.1 Cable sockets, straight, with cables

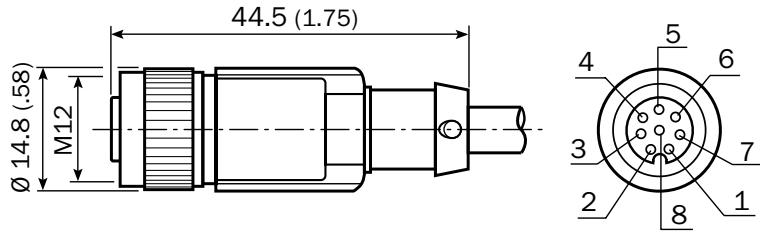

All dimensions in mm

Fig. 33: Cable socket M16, 8-pin, straight, shielded

Description	Female connector, M12, 8-pin, straight, 2m, PUR halogen free, shielded, twisted in pairs for SSI and HIPERFACE
Type	DOL-1208-G02MAH1
Part no.	6032448
Description	Female connector, M12, 8-pin, straight, 5m, PUR halogen free, shielded, twisted in pairs for SSI and HIPERFACE
Type	DOL-1208-G05MAH1
Part no.	6032449
Description	Female connector, M12, 8-pin, straight, 10m, PUR halogen free, shielded, twisted in pairs for SSI and DME HIPERFACE
Type	DOL-1208-G10MAH1
Part no.	6032450
Description	Female connector, M12, 8-pin, straight, 20m, PUR halogen free, shielded, twisted in pairs for SSI and DME HIPERFACE
Type	DOL-1208-G20MAH1
Part no.	6032451

15.2.2 Cable

Description	Cable, by meter, 8-pin, PUR halogen free, shielded, twinned pair
Type	LTG-3108-MW
Part no.	6032456
Temperature range	<ul style="list-style-type: none">• Moved: -25 ... +60 °C• Fixed: -50 ... +80 °C
Sheath	PUR black
Shield	Tinned copper braid

Accessories

15.3 Mounting systems

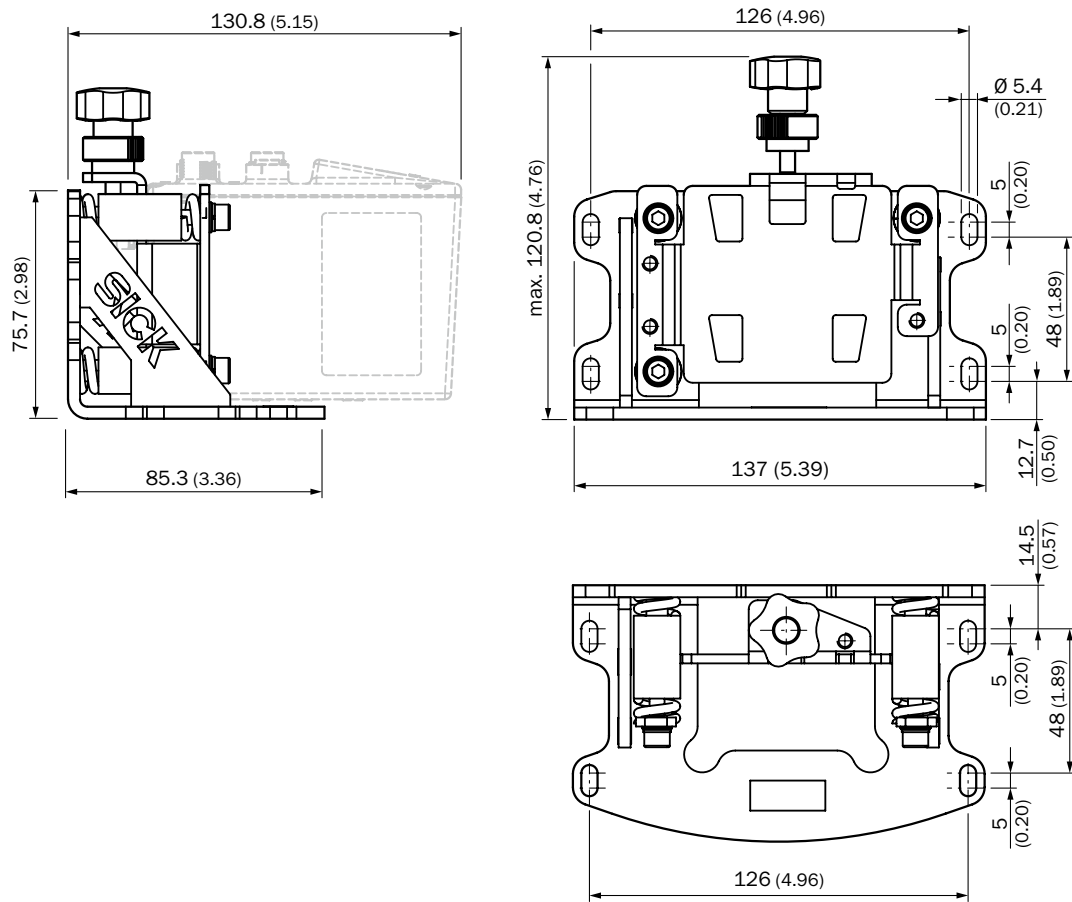

All dimensions in mm (inch)

Fig. 34: Alignment bracket

Description	Alignment bracket
Type	BEF-AH-DX100
Part no.	2058653
Material:	Zinc-plated steel sheet

15.4 Other accessories

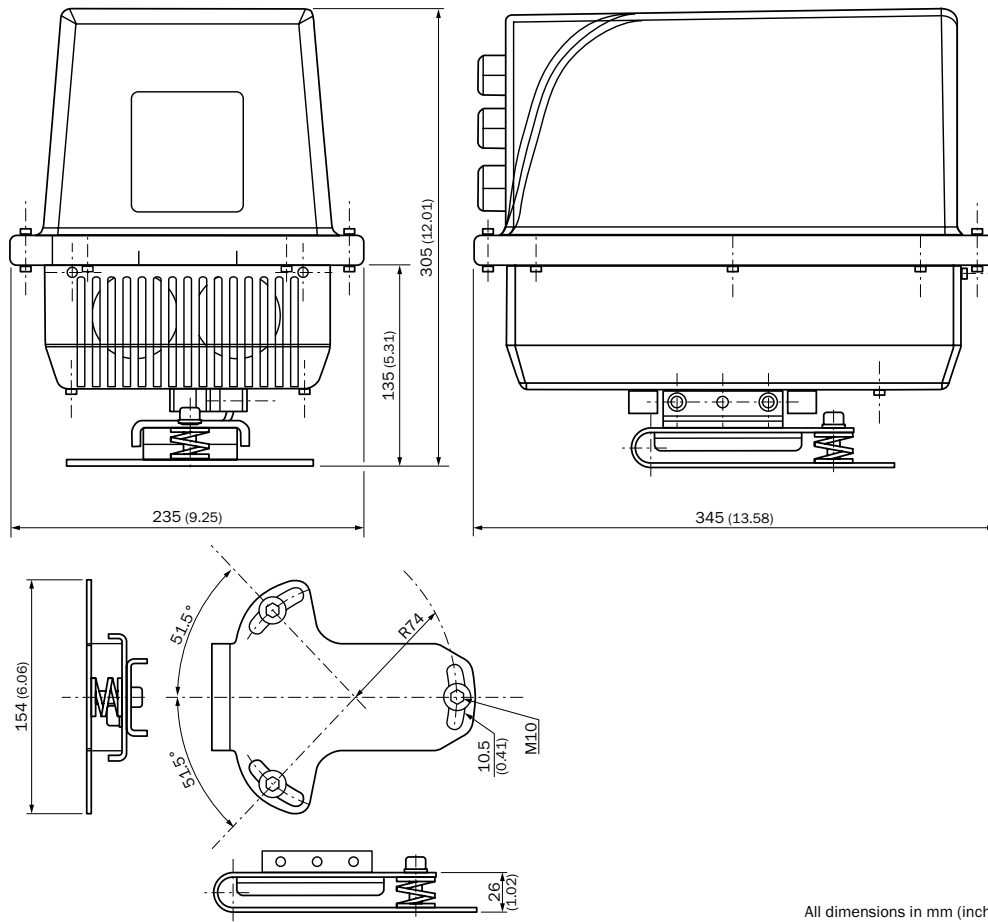
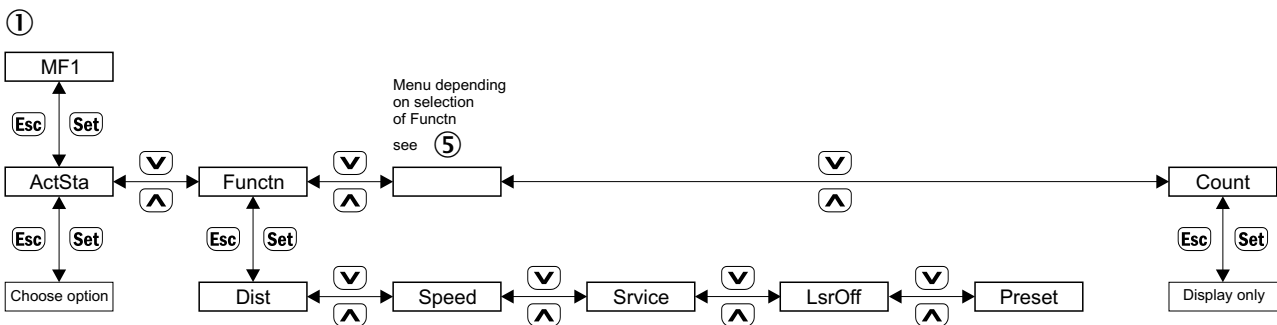
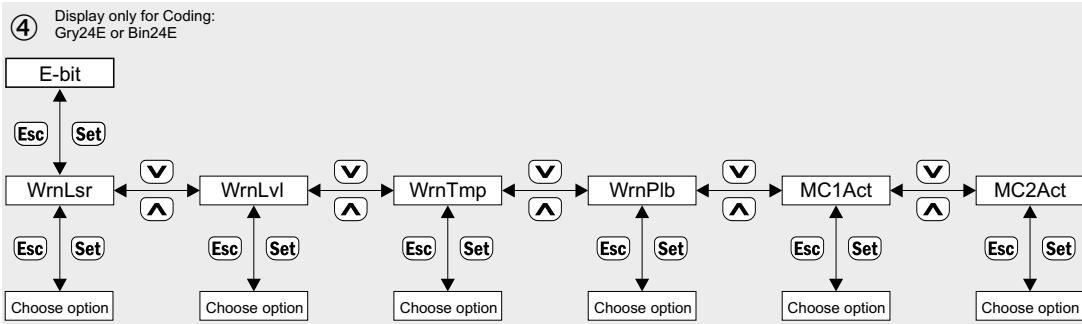
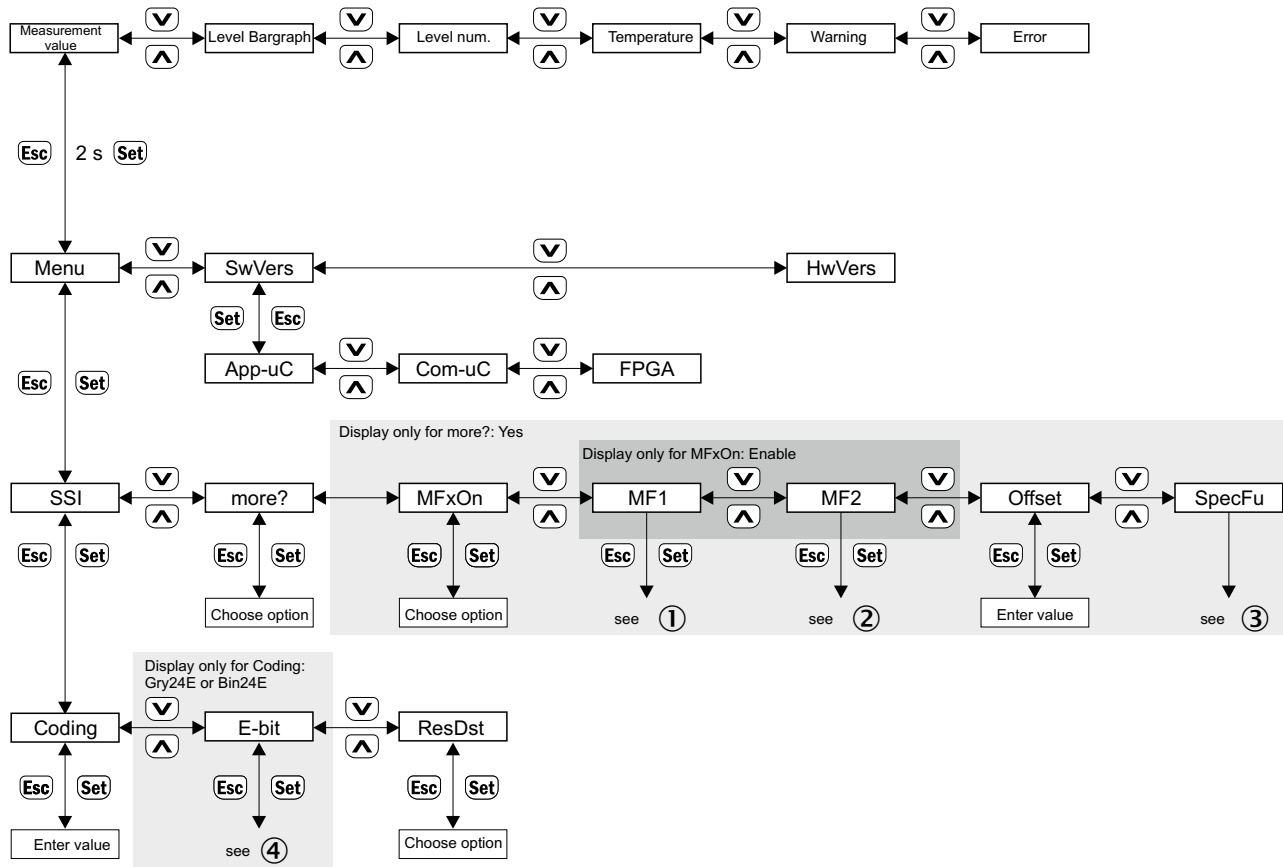

Fig. 35: Cooling Casing

Description	Cooling Casing
Type	TPCC-Dx100
Part no.	6048328
Material:	Glass-fiber reinforced plastic (GFK)
Operating ambience temperature	-20 ... +75 °C (short-term +80 °C)
Supply voltage	24 V DC ± 20 %
Current consumption	15 A at 24 V DC
Enclosure rating	IP 54

Menu structure

16 Menu structure



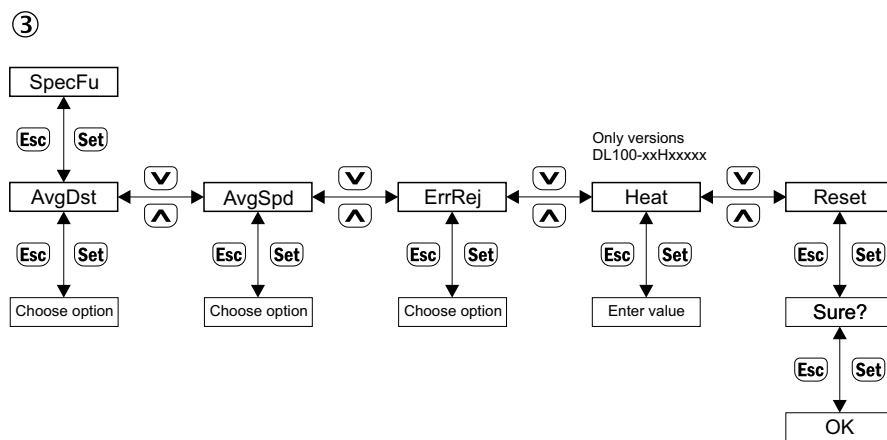
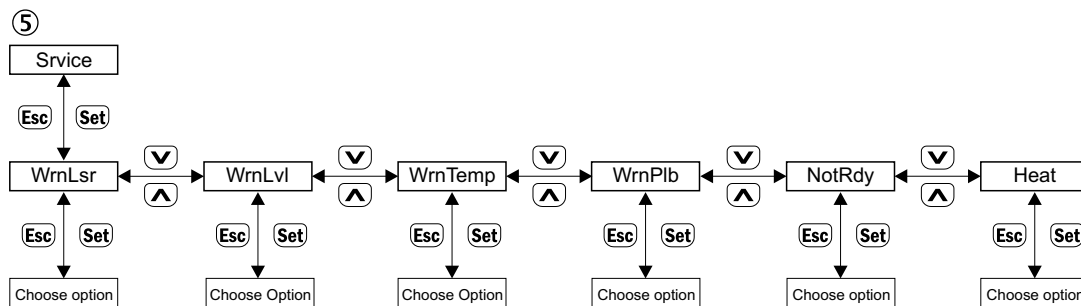
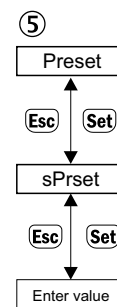
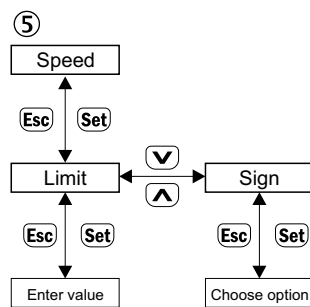
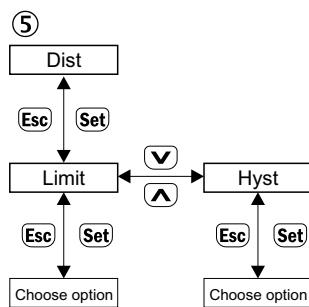
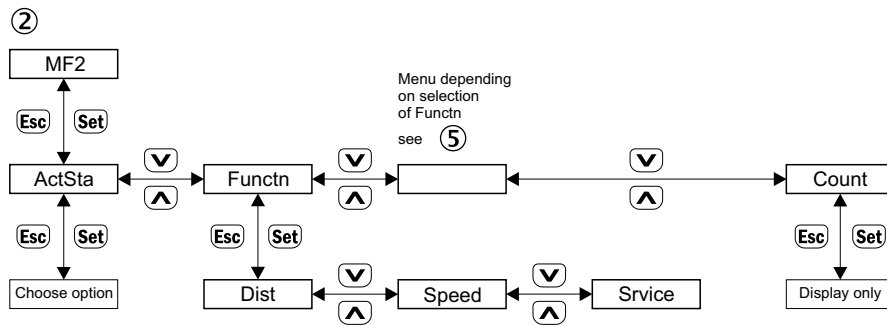

Index

Index

A		M	
Accessories.....	78	Mounting.....	23
Align		Distance measuring device and adjacent data	
Distance measuring device and reflector	28	transmission photoelectric switch.....	27
Ambient conditions	76	Mount alignment bracket and distance measuring	
		device.	29
C		Multiple distance measuring device	25
Changes.....	12	Mounting notes	23
Connection diagrams.....	36	Mounting process	23
Constructive setup	77	Mounting systems	83
Conversions.....	12		
Customer service	10	N	
		Non-Intended Use	12
D			
Danger notes	15	O	
Delivery	10	Operating elements.....	19
Dimensions.....	73	Operating instructions	8
Display	20	Operating modes.....	20
Disposal	71	Operating staff	
		Requirements	13
E		Operation	38
EC Declaration of Conformity	11	Operational safety.....	13, 15
Electrical connection.....	32	Outputs	75
Electricians	13		
Environmental protection	11	P	
Ethernet	53	Parameter description	39
		Performance data	75
F			
Function	18	R	
		Reflective tape.....	80
G		Reflectors.....	78
General	8	Repair.....	71
		Return	71
I			
Identification.....	16	S	
Inputs	75	Safety	12
Instructed persons	13	Electrical connection.....	32
Intended Use	12	Setup.....	17
		Skilled persons.....	13
K		Requirements	13
Keys.....	20	Status indicators	19
		Storage.....	22
L		Supply	75
Laser	74		
Laser irradiation	15	T	
LEDs.....	19	Technical data	72
Limitations of liability.....	10	Transport.....	21
		Transport inspection	21
		Troubleshooting.....	69
		Type Label.....	16

U

UL safety notes..... 7

W

Wiring notes..... 32

Australia

Phone +61 3 9457 0600
1800 334 802 – tollfree
E-Mail sales@sick.com.au

Austria

Phone +43 22 36 62 28 8-0
E-Mail office@sick.at

Belgium/Luxembourg

Phone +32 2 466 55 66
E-Mail info@sick.be

Brazil

Phone +55 11 3215-4900
E-Mail marketing@sick.com.br

Canada

Phone +1 905 771 14 44
E-Mail information@sick.com

Czech Republic

Phone +420 2 57 91 18 50
E-Mail sick@sick.cz

Chile

Phone +56 2 2274 7430
E-Mail info@schadler.com

China

Phone +86 20 2882 3600
E-Mail info.china@sick.net.cn

Denmark

Phone +45 45 82 64 00
E-Mail sick@sick.dk

Finland

Phone +358-9-2515 800
E-Mail sick@sick.fi

France

Phone +33 1 64 62 35 00
E-Mail info@sick.fr

Germany

Phone +49 211 5301-301
E-Mail info@sick.de

Hong Kong

Phone +852 2153 6300
E-Mail ghk@sick.com.hk

Hungary

Phone +36 1 371 2680
E-Mail office@sick.hu

India

Phone +91 22 6119 8900
E-Mail info@sick-india.com

Israel

Phone +972 4 6881000
E-Mail info@sick-sensors.com

Italy

Phone +39 02 274341
E-Mail info@sick.it

Japan

Phone +81 3 5309 2112
E-Mail support@sick.jp

Malaysia

Phone +6 03 8080 7425
E-Mail enquiry.my@sick.com

Mexico

Phone +52 (472) 748 9451
E-Mail mario.garcia@sick.com

Netherlands

Phone +31 30 2044 000
E-Mail info@sick.nl

New Zealand

Phone +64 9 415 0459
0800 222 278 – tollfree
E-Mail sales@sick.co.nz

Norway

Phone +47 67 81 50 00
E-Mail sick@sick.no

Poland

Phone +48 22 539 41 00
E-Mail info@sick.pl

Romania

Phone +40 356 171 120
E-Mail office@sick.ro

Russia

Phone +7 495 775 05 30
E-Mail info@sick.ru

Singapore

Phone +65 6744 3732
E-Mail sales.gsg@sick.com

Slovakia

Phone +421 482 901201
E-Mail mail@sick-sk.sk

Slovenia

Phone +386 591 788 49
E-Mail office@sick.si

South Africa

Phone +27 11 472 3733
E-Mail info@sickautomation.co.za

South Korea

Phone +82 2 786 6321
E-Mail info@sickkorea.net

Spain

Phone +34 93 480 31 00
E-Mail info@sick.es

Sweden

Phone +46 10 110 10 00
E-Mail info@sick.se

Switzerland

Phone +41 41 619 29 39
E-Mail contact@sick.ch

Taiwan

Phone +886 2 2375-6288
E-Mail sales@sick.com.tw

Thailand

Phone +66 2645 0009
E-Mail Ronnie.Lim@sick.com

Turkey

Phone +90 216 528 50 00
E-Mail info@sick.com.tr

United Arab Emirates

Phone +971 4 88 65 878
E-Mail info@sick.ae

United Kingdom

Phone +44 1727 831121
E-Mail info@sick.co.uk

USA

Phone +1 800 325 7425
E-Mail info@sick.com

Vietnam

Phone +84 945452999
E-Mail Ngo.Duy.Linh@sick.com