

# LD-MRS

3D LiDAR sensors



**Software version described**

Device/Software/Tool	Function	Version
LD-MRS400001 (LD-MRS)	Firmware (DSP) Firmware (FPGA)	as of V. 2.0.x as of V. 9.0.x
LD-MRS400102 (LD-MRS HD)	Firmware (DSP) Firmware (FPGA)	as of V. 2.0.x as of V. 9.0.x
LD-MRS420201 (LD-MRS UAV)	Firmware (DSP) Firmware (FPGA)	as of V. 2.0.x as of V. 9.0.x
LD-MRS800001 (LD-MRS 8-Layer)	Firmware (DSP) Firmware (FPGA)	as of V.3.0.x as of V.9.6.x
SOPAS ET <sup>1)</sup>	Configuration software for field monitoring	as of V. 2.22
SICK LaserView Customer Edition <sup>1)2)</sup>	Configuration software and visualization tool for measuring mode	as of V. 1.5.4
<p>1) Can run on a computer with an operating system starting at Windows 2000™</p> <p>2) For installation and use, see the operating instructions "Visualization tool SICK LaserView Customer Edition" (Part No. 8013787, English version) on the provided CD, "Manuals &amp; Software LD-MRS" The visualization tool "SICK LaserView Customer Edition" will henceforth be called „LaserView“.</p>		

**Copyright**

Copyright © 2009 - 2017

SICK AG Waldkirch  
Auto Ident, Reute plant  
Nimburger Strasse 11  
79276 Reute  
Germany

**Trademark**

Windows 2000™, XP™, Vista™, Windows 7™, Windows 8™, Windows 10™ are registered trademarks or trademarks of the Microsoft Corporation in the USA and other countries.

Adobe® Reader® is a registered trademark of Adobe Systems Incorporated.

Download via Internet: <http://get.adobe.com/reader/>

**Version of these operating instructions**

The latest version of these operating instructions can be obtained as PDF at [www.sick.com](http://www.sick.com).



<b>Content</b>	
<b>1</b>	<b>About this document ..... 9</b>
1.1	Function ..... 9
1.2	Target group ..... 9
1.3	Depth of information ..... 9
1.4	Symbology used ..... 10
<b>2</b>	<b>For your safety ..... 11</b>
2.1	Safety standards ..... 11
2.2	Authorized personnel ..... 11
2.3	Intended use ..... 12
2.4	General safety notes and protective means ..... 13
2.5	Quick stop and Quick restart ..... 15
2.6	Environmental protection ..... 15
<b>3</b>	<b>Product description ..... 17</b>
3.1	Design of the device ..... 17
3.2	Scope of delivery ..... 19
3.3	System requirements ..... 21
3.4	Operating principle of the device ..... 22
3.5	Measuring mode ..... 37
3.6	Object Tracking (LD-MRSxxx.S01 only) ..... 39
3.7	Mounting upside down (LD-MRS 8-Layer only) ..... 47
3.8	Field monitoring (for LD-MRS400xxx only) ..... 48
3.9	Function of the 8-layer sensors ..... 52
3.11	Status indicators and controls ..... 55
<b>4</b>	<b>Mounting ..... 57</b>
4.1	Overview of the mounting steps ..... 57
4.2	Preparations for mounting ..... 57
4.3	Mounting and adjustment of the device ..... 58
4.4	Mount the optional CAN module ..... 62
4.5	Dismounting the device ..... 63
<b>5</b>	<b>Electrical installation ..... 65</b>
5.1	Overview of the installation steps ..... 65
5.2	Planning the electrical installation ..... 66
5.3	Electrical connections and cables ..... 67
5.4	Perform electrical installation ..... 70
5.5	Pin assignments and wire colors of the assembled cables ..... 79
<b>6</b>	<b>Commissioning and configuration ..... 82</b>
6.1	Overview for the startup steps for field monitoring ..... 82
6.2	SOPAS-ET configuration program ..... 82
6.6	Synchronization ..... 86
6.7	Switching off the LD-MRS ..... 88
<b>7</b>	<b>Maintenance ..... 90</b>
7.1	Maintenance during operation ..... 90
7.2	Cleaning the device ..... 90
7.3	Exchanging an LD-MRS ..... 91
<b>8</b>	<b>Troubleshooting ..... 92</b>
8.1	Warnings and fault messages ..... 92
8.2	Overview of possible errors and faults ..... 92
8.3	Monitor error and fault indications ..... 92
8.4	Troubleshooting ..... 93
8.5	SICK Support ..... 94
<b>9</b>	<b>Technical specifications ..... 95</b>
9.1	Data sheets ..... 95
9.2	Dimensional drawings ..... 98
9.3	Conditions for integrating the LD-MRS ..... 105
<b>10</b>	<b>Annex ..... 107</b>
10.1	Overview of the annex ..... 107

10.2	Additional documentation.....	107
10.3	Ordering information .....	107
10.4	Glossary.....	108
10.5	EC Declaration of Conformity.....	109

**Abbreviations**

<b>CAN</b>	Controller Area Network = Standardized field bus system with a message-oriented data exchange protocol
<b>EEPROM</b>	Electrically Erasable Programmable Read-only Memory = non-volatile memory that can be electrically erased and programmed
<b>LED</b>	Light Emitting Diode = light emitting diode
<b>INT</b>	Integer
<b>LD</b>	Ladar Digital (Ladar = Laser Radar)
<b>MRS</b>	Multi-Layer Range Scanner
<b>RAM</b>	Random Access Memory = volatile memory with direct access
<b>ROM</b>	Read-only Memory = memory that can only be read (non-volatile)
<b>SOPAS-ET</b>	SICK OPEN PORTAL for APPLICATION and SYSTEMS Engineering Tool = Configuration software for configuring the LD-MRS
<b>UAV</b>	Unpiloted Aerial Vehicles
<b>UINT</b>	Unsigned Integer

**Tables**

Tab. 1-1: Target group ..... 9

Tab. 2-1: Required qualification for commissioning the LD-MRS ..... 11

Tab. 2-2: Power consumption of the LD-MRS ..... 15

Tab. 3-1: Delivery of LD-MRS..... 19

Tab. 3-2: Contents of the CD-ROM "Manuals & Software LD-MRS" ..... 19

Tab. 3-3: Device variants of the LD-MRS..... 20

Tab. 3-4: Product features and functions (overview) ..... 21

Tab. 3-5: Naming conventions (colour code see [Fig. 3-5](#)) ..... 26

Tab. 3-6: Angular resolution 0.125° ..... 31

Tab. 3-7: Angular resolution 0.25° ..... 31

Tab. 3-8: Angular resolution 0.5° ..... 31

Tab. 3-9: Setting the layer sensitivity..... 44

Tab. 3-10: Example of a combination of inputs ..... 49

Tab. 5-1: Pin assignment of the 4-pin socket (round plug-in connection) "Ethernet" . 67

Tab. 5-2: Pin assignment of the 12-pin plug "data interfaces/synchronization" (round plug-in connection)..... 67

Tab. 5-3: Pin assignment of the 4-pin plug "Power" (round plug-in connection) ..... 68

Tab. 5-4: Assembled cables for connecting the LD-MRS ..... 68

Tab. 5-5: Power consumption of the LD-MRS ..... 70

Tab. 5-6: Pin assignment of the Ethernet data cable..... 79

Tab. 5-7: Pin assignment of the connecting cable "Synchronization" ..... 79

Tab. 5-8: Pin assignment of the cable splitter 1:3..... 80

Tab. 5-9: Pin assignment of the CAN connecting cable ..... 81

Tab. 5-10: Wire colour assignment of the supply cable ..... 81

Tab. 6-1: Default setting of SOPAS-ET ..... 83

Tab. 6-2: Password ..... 85

Tab. 8-1: Troubleshooting the LD-MRS..... 93

Tab. 9-1: Technical specifications LD-MRS ..... 95

Tab. 9-2: Technical specifications for the CAN modules (from the manufacturer's data sheets and manuals) ..... 97

Tab. 10-1: Additional documentation ..... 107

Tab. 10-2: Consumables for the care of the LD-MRS ..... 107

**Figures**

Fig. 2-1: Laser output aperture of the LD-MRS..... 15

Fig. 3-1: Design of the LD-MRS..... 18

Fig. 3-2: Principle of time-of-flight measurement..... 23

Fig. 3-3: Multi-echo capability..... 24

Fig. 3-4: Multi-layer technology..... 25

Fig. 3-5: Principle of the scan planes, color-coded ..... 25

Fig. 3-6: Scanning range ..... 27

Fig. 3-7: Relation of angle to scanning range..... 28

Fig. 3-8: Sensing range in relation to remission..... 29

Fig. 3-9: Example of three echoes of a laser pulse ..... 30

Fig. 3-10: Angular resolution..... 30

Fig. 3-11: Example: Angular resolution of 0.25° at distance d = 25 m (82 ft) ..... 31

Fig. 3-12: Different angular resolution by sector ..... 32

Fig. 3-13: Scanning frequency 12.5 Hz with constant angular resolution of 0.25° ..... 33

Fig. 3-14: Scanning frequency 25 Hz with constant angular resolution of 0.25° ..... 33

Fig. 3-15: Scanning frequency 50 Hz with constant angular resolution of 0.5° ..... 34

Fig. 3-16: Reflection of the laser beam at the surface of an object..... 35

Fig. 3-17: Reflection angle ..... 35

Fig. 3-18: Degree of reflection ..... 35

Fig. 3-19:	Mirror surfaces .....	36
Fig. 3-20:	Object smaller than diameter of the laser beam .....	36
Fig. 3-21:	Raw data .....	40
Fig. 3-22:	Object contour .....	41
Fig. 3-23:	Bounding box .....	41
Fig. 3-24:	Object .....	42
Fig. 3-25:	„Suppressor“ filter .....	43
Fig. 3-26:	Setting the near range sensitivity .....	44
Fig. 3-27:	Example for measurement result with „Clutter“ .....	45
Fig. 3-28:	„Noise Control“-Filter .....	46
Fig. 3-29:	Device parameter: Upside down mounting .....	47
Fig. 3-30:	Principle of field monitoring .....	48
Fig. 3-31:	Manipulation protection against shadow .....	50
Fig. 3-32:	Examples of evaluation field shapes .....	51
Fig. 3-33:	Function of the 8-layer sensors – upper scan field .....	52
Fig. 3-34:	Function of the 8-layer sensors – lower scan field .....	52
Fig. 3-35:	Function of the 8 layer sensor – overlapping scan fields .....	53
Fig. 3-36:	μCAN.8.dio-SNAP module .....	54
Fig. 3-37:	μCAN.8.dio-BOX module .....	55
Fig. 4-1:	Beam expansion .....	58
Fig. 4-2:	Mount the LD-MRS on holder Part No. 1047429 .....	59
Fig. 4-3:	Adjust the holder .....	60
Fig. 4-4:	Mount the LD-MRS on the weather resistant cover Part No. 2058033 and on the holder Part No. 1047429 .....	61
Fig. 4-5:	Mount the optional CAN module .....	62
Fig. 5-1:	Measuring mode: Electrical installation of the LD-MRS .....	65
Fig. 5-2:	Field monitoring: Electrical installation of the LD-MRS and the CAN module .....	65
Fig. 5-3:	Connection of the voltage supply and wiring of the Ethernet interface .....	71
Fig. 5-4:	Design of the CAN module μCAN.8.dio-BOX .....	72
Fig. 5-5:	Design of the CAN module μCAN.8.dio-SNAP .....	73
Fig. 5-6:	Connect two CAN modules to the CAN interface of the LD-MRS .....	74
Fig. 5-7:	Connect one CAN module to the CAN interface of the LD-MRS .....	74
Fig. 5-8:	Input switched against $V_{+PWR}$ .....	75
Fig. 5-9:	A circuit diagram of digital I/O terminal (high side driver) .....	76
Fig. 5-10:	DIP switch for address (example: address 9) .....	76
Fig. 5-11:	DIP switch for transmission rate (example: 500 kBit/s) .....	77
Fig. 5-12:	Wiring of the RS-232 interface .....	78
Fig. 6-1:	Principle of data storage .....	85
Fig. 6-2:	Scheme of the data flow in a system with one LD-MRS and up to two external devices .....	86
Fig. 6-3:	Details synchronisation .....	87
Fig. 6-4:	LD-MRS: Sync IN and Sync Out pulse .....	88
Fig. 9-1:	Dimensions of the LD-MRS .....	98
Fig. 9-2:	Dimensions of the LD-MRS .....	99
Fig. 9-3:	Position of the sensor coordinate origin in the LD-MRS UAV .....	100
Fig. 9-4:	Dimensions of the holder Part No. 1047429 .....	101
Fig. 9-5:	Dimensions of the weather resistant cover Part no. 2058033 .....	102
Fig. 9-6:	Dimensions of the two designs of the CAN modules .....	103
Fig. 9-7:	Dimensions of the shock mounting .....	104
Fig. 9-8:	Boundary conditions for integration .....	105
Fig. 10-1:	Illustration containing the EC Declaration of Conformity, page 1 (size reduced)	109

# 1 About this document

## 1.1 Function

This document informs technical personnel how to safely install and operate these versions of the LD-MRS laser measurement sensor:

- LD-MRS400001 (standard version)
- LD-MRS400102 (heavy duty version)
- LD-MRS420201 (UAV-Version with light housing)
- LD-MRS800001 (standard version with 8 layers)

The document contains information about

- Mounting and electrical installation
- Commissioning and configuration (parametrization)
- Maintenance
- Troubleshooting
- Replacing the laser measurement sensor

**Important** In the following, the LD-MRS400001, LD-MRS400102, LD-MRS420201 and LD-MRS800001 laser measurement sensors are termed "LD-MRS" for short, except in cases where differences need to be explained specifically.

## 1.2 Target group

The target group of this document are people in the following positions:

Activities	Target group
Mounting, electrical installation, maintenance, replacement	Qualified personnel, e.g. service technicians, factory electricians
Commissioning, configuration	Qualified personnel, e.g. technicians, engineers

Tab. 1-1: Target group

## 1.3 Depth of information

This document contains all information required for mounting, electrical installation and commissioning of the LD-MRS with **factory settings**.

All tasks are described step by step.

The configuration of the LD-MRS for user-specific situations in **measuring mode** as well as measurement queries for displaying the scan data are done via the provided visualization tool SICK LaserView Customer Edition or with messages. The LaserView software is also used to configure the object data. Further Information is available in the corresponding document Article no. 8013787.

To configure **field monitoring**, use the SOPAS-ET configuration software. SOPAS-ET can also display scanning data from measuring mode.

Further information about laser measurement technology is available from SICK AG, Division Auto Ident, and on the internet at [www.sick.com](http://www.sick.com).

## 1.4 Symbology used

Some information in this documentation are highlighted to facilitate quick access to these information:



## NOTICE

### Note!

A note indicates potential hazards that could involve damage or degradation of the functionality of the LD-MRS.



## WARNING

### Warning!

A warning indicates an actual or potential hazard for the physical integrity of the user. They are designed to help to prevent accidents.

The safety symbol beside the warning indicates the nature of the risk of accident, e. g. due to electricity. The incremental warning category (CAUTION, WARNING, DANGER) indicates the severity of the hazard.

- Always read carefully and follow the warning notices.

*Cross-reference* Text in italics indicates a reference to more detailed information.

**Important** This important note informs about special issues.

**Explanation** An explanation provides background knowledge about technical relations.

**Recommendation** Recommendations are designed to assist in the decision-making process with respect to a certain function or a technical measure.

**Basic settings** Marks a section listing the values of the factory settings.

**BAUD RATE** This typeface indicates a term in the configuration software SOPAS-ET.



This symbol identifies a section that describes the operating steps with the SOPAS-ET configuration software.



This symbol refers to supplementary technical documentation.

- Instructions for taking action are shown by an arrow. This symbol indicates an instruction that only consists of one step, or a warning note with several steps that do not require any particular order.

Multiple step instructions in a required sequence are identified by a sequential numbers.

## 2 For your safety

This chapter deals with your own safety.

- Read this chapter carefully **before** using the LD-MRS.

### 2.1 Safety standards

The LD-MRS has been designed and manufactured under consideration of a risk analysis and careful selection of the pertinent harmonized standards as well as other technical specifications. Hence, the LD-MRS matches state-of-the-art technology.

In design and production, established technological rules have been applied and observed. Development and production in SICK AG ensure this quality standard by a certified quality management system according to EN ISO 9001:2008.

If the user adheres to all safety notes in this operating instructions and uses the device as intended, he is sufficiently protected.

## 2.2 Authorized personnel

The LD-MRS must be mounted and operated by qualified personnel to ensure its proper and safe function.

**Important** Only trained and authorized service personnel of SICK AG may repair the LD-MRS.

The different tasks require the following qualification:

Activities	Qualification
Mounting, maintenance	<ul style="list-style-type: none"> <li>- practical technical basic training</li> <li>- knowledge of the established safety rules at work</li> </ul>
Electrical installation, device replacement	<ul style="list-style-type: none"> <li>- practical electrical training</li> <li>- knowledge of the established electric safety rules</li> </ul>
Commissioning, configuration	<ul style="list-style-type: none"> <li>- basic knowledge of Windows™ in the version used on site</li> <li>- basic knowledge of data transmission</li> <li>- Basic knowledge of how to establish and set up (address) Ethernet connections when connecting the LD-MRS to the Ethernet</li> <li>- Basic knowledge of how to establish and set up a CAN network when using field monitoring</li> </ul>
Processing the measured values in EDP systems	<ul style="list-style-type: none"> <li>- Programming skills for the application to be created in measuring mode</li> </ul>

Tab. 2-1: Required qualification for commissioning the LD-MRS

## 2.3 Intended use

The LD-MRS allows two applications with its radial field of view:

- The detection of objects around the location or installation site while continuously outputting measurements upon request, or
- Field monitoring of freely definable areas while signaling field violations via external switch outputs

The device is designed for application in the industrial sector, in particular outside.

**Important** Every other use as well as modifications to the device, including those within the course of mounting and electrical installation, will render void any warranty claim towards SICK AG.

- Only operate the LD-MRS in the permitted ambient temperature range, see [Chapter 9 Technical specifications, Page 94](#).

The user of the LD-MRS has to ensure that

- the device is only used in compliance with the listed specifications and environment conditions, see [Chapter 9.1 Data sheets, Page 94](#),
- country-specific standards and regulations are adhered to, depending on the kind of operation,
- the device is only used in proper, functional state,
- safety and warning labels attached to the device are not removed or covered and remain readable,
- the operating instructions are available on site in a readable form and that the authorized personnel had read the operating instructions and is thus sufficiently qualified.

**Important** **Loss of warranty!**

The housing of the laser measurement sensor LD-MRS is closed with a seal. Breaking the seal and opening the device causes a loss of warranty claims towards SICK AG. The housing may only be opened by authorized service personnel of SICK AG.

## 2.4 General safety notes and protective means

- Read the general safety notes carefully and strictly observe them in when working at or with the LD-MRS. Also observe the warning notes printed before the instructions in the individual chapters of this document.



### WARNING

#### Safety notes

Observe the following points in order to ensure safe use as intended of the LD-MRS:

- The user must ensure that every person working on or with the LD-MRS has read and understood these operating instructions.
- Official and legal requirements must be adhered to when operating the LD-MRS.
- For installation and usage of the LD-MRS as well as for commissioning and regular technical inspection, national/international legal requirements apply, in particular
  - the accident prevention regulations/safety rules
  - other pertinent safety rules
- Adhere to the following safety notes in order to prevent dangers for persons and/or property:
  - **The operator must ensure by suitable instructions and inspections that the window of the LD-MRS is always clean.**
  - Additionally, the local safety and accident prevention regulations apply for operating the LD-MRS.
  - A defect of the control functions can cause danger for human life or property damage at the LD-MRS.
- Data integrity  
 In its products, SICK AG uses information technology, such as IO-Link or standard IP technology. The focus is on the availability of the products and their features. It is the consistent assumption of SICK AG that the user will maintain the integrity and confidentiality of data and rights that are affected by the use of the products.  
 The user must observe appropriate safety measures such as network separation, firewalls, viral protection and patch management according to the situation.

### 2.4.1 Range of application



### WARNING

**Not permitted for personal protection!**

**The LD-MRS is NOT a device for ensuring personal protection as defined by applicable safety standards for machines!**

### 2.4.2 Electrical installation tasks

- Only trained personnel may perform the electrical installation.
- Electrical connection may only be established or disconnected when not under voltage.
- Specify and implement the wire diameter and the correct fusing according to valid standards.

### 2.4.3 Malfunctions

#### CAN modules for external switching inputs and outputs (accessories)

## NOTICE

#### Potential radio interference when using the optional CAN modules in residential areas.

- Only use the laser measurement sensor LD-MRS together with the CAN modules in an industrial setting.

### 2.4.4 Laser protection



## CAUTION

#### Laser radiation!

The LD-MRS uses infrared light laser. The device is specified as laser class 1 (eye-safe). The laser beam is invisible to the human eye!

Caution – use of controls, adjustments or performance of procedures other than those specified herein may result in hazardous radiation exposure.

- Do not open the housing of the LD-MRS (opening the housing does not interrupt laser operation).
- Observe the valid laser protection regulations in their newest version.

#### Laser power

The laser operates at a wave length  $\lambda =$  approx. 905 nm (invisible infrared light).

The product is classified as laser class 1 EN/IEC 60825-1:2014, 21 CFR 1040.10 and 21 CFR 1040.11. Identical laser class for issue EN/IEC 60825-1:2007. The radiation emitted in normal operation is not harmful to the eyes and human skin.

**Important** In order to ensure laser class 1, no maintenance is necessary.

#### Laser output aperture

The laser output aperture is the window of the LD-MRS.



Fig. 2-1: Laser output aperture of the LD-MRS

Caption:

1 Window

## 2.5 Quick stop and Quick restart

The device has no separate switch for the supply voltage.

### 2.5.1 Switching off the LD-MRS

- Switch off the supply voltage by disconnecting from the supply system, or loosen and remove the supply cable at the "Power" connection.

### 2.5.2 Switching on the LD-MRS

- Switch on the supply voltage or connect the supply cable again with the "Power" connection.  
The LD-MRS starts operation with the **most recently stored permanently** parameter set.

## 2.6 Environmental protection

The LD-MRS has been designed to minimize environmental impact.

### 2.6.1 Energy consumption

At 9 to 27 V DC, the LD-MRS draws the following:

Process	Power consumption
Switch-on	typically 36 W (1.5 A at 24 V DC)
permanent operation	typically 8 W (0.34 A at 24 V DC)
permanent operation	max. 10 W (0.4 A at 24 V DC)

Tab. 2-2: Power consumption of the LD-MRS

The optional CAN module consumes approximately 1.5 W at 8 to 50 V DC without a load.

### **2.6.2 Disposal after final decommissioning**

Currently the SICK AG does not offer a return service for inoperative or irreparable devices.

- Always dispose of unserviceable or irreparable devices in compliance with local/national rules and regulations on waste disposal.

The design of the LD-MRS allows for recovery of secondary raw material and hazardous waste (e-scrap).

## 3 Product description

This chapter provides information on design, special features and properties of the LD-MRS.

- For information on assembly, electrical installation and startup of the LD-MRS, consult the section **before** starting.

### 3.1 Design of the device

The laser measurement sensor LD-MRS consists of a laser measurement system and a mirror construction. The components - laser measurement system and mirror construction - are mounted in a rugged housing.

When looking from the front at the LD-MRS, the right side of the device contains three connections ("Ethernet", "Data interfaces/synchronization" and "Power"), the left side contains a ventilation unit.

At the rear side of the device, four protruding lugs have a hole each to attach the device at the point of installation.



3.1.1 Device view

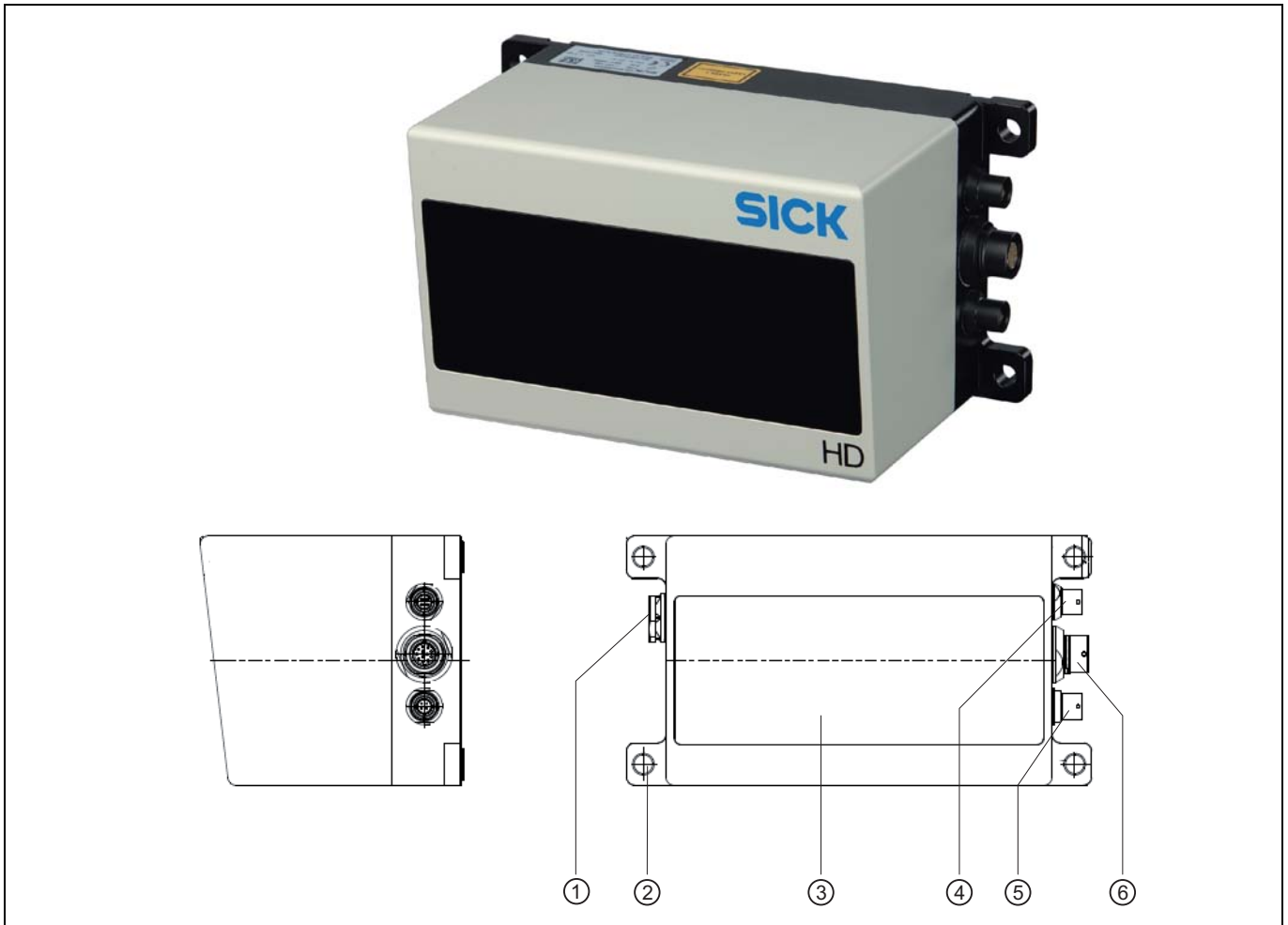

Fig. 3-1: Design of the LD-MRS

Caption:

- 1 Ventilation element
- 2 Mounting hole  $\varnothing$  6.6 mm (4 x)
- 3 Window
- 4 "Ethernet" connection
- 5 "Power" connection
- 6 Data interfaces/synchronization connection

### 3.2 Scope of delivery

The LD-MRS delivery includes the following components:

Quantity	Component	Comment
1	Laser measurement sensor LD-MRS	Type depending on order
1	Notes on Device with information and electrical circuit diagram for getting started	Included in the LD-MRS packaging
1	CD-ROM "Manuals & Software LD-MRS"	

Tab. 3-1: Delivery of LD-MRS

The product information for the LD-MRS laser measurement sensor (Part No. 8012945) contains all of the ordering information for the product and accessories.

[Chapter 10.3 Ordering information, Page 105](#) provides an overview of consumables for care and maintenance of the LD-MRS.

#### 3.2.1 Contents of the CD, "Manuals & Software LD-MRS" (Part No. 2050264)

Component	Comment
SoftwareSICK LaserView Customer Edition	Visualization tool for measurements; can run on standard computers (Windows™ and Linux)
Software SOPAS-ET	Configuration software for field monitoring including online help (Java), can run on standard computers (Windows™)
Operating instructions for the "laser measurement sensor LD-MRS"	PDF version in German and English
Operating instructions for the "SICK LaserView Customer Edition visualization tool"	PDF version in German and English
Ethernet Data Protocol	PDF in German and English
CAN Data Protocol	PDF in German and English

Tab. 3-2: Contents of the CD-ROM "Manuals & Software LD-MRS"

**Important** The publications and programs on the CD-ROM are also available for download at [www.sick.com](http://www.sick.com).

Download address for PDF visualization software in the Internet:

<http://get.adobe.com/reader/>

LD-MRS

### 3.2.2 Device variants

The LD-MRS is available in the following variants:

Part No.	Designation	Type	Description
1045046	LD-MRS	LD-MRS400001	Scanning range 50 m (164 ft) at 10 % remission, measurement on 4 planes, enclosure rating IP 69k
1047145	LD-MRS HD	LD-MRS400102	Scanning range 30 m (98,4 ft) at 10 % remission, measurement on 4 planes, heavy duty, particularly robust in dusty environments and areas with spraying liquids, enclosure rating IP 69k
1085081	LD-MRS UAV	LD-MRS420201	Scanning range 50 m (164 ft) at 10 % remission, measurement on 4 planes, particularly suited and light housing, enclosure rating IP 69k
1069408	LD-MRS 8-Layer	LD-MRS800001	Scanning range 50 m at 10 % remission, measurement on up to 8 layers, IP 69k

Tab. 3-3: Device variants of the LD-MRS

### 3.3 System requirements

For general system requirements refer to the data sheet for the LD-MRS (see [Chapter 9 Technical specifications, Page 94](#)).

The requirements for [Mounting](#), [Electrical installation](#) and [Commissioning and configuration](#) are summarized in the respective chapters.

#### 3.3.1 Product features and functions (overview)

Performance feature	Characteristic
General advantages	<ul style="list-style-type: none"> <li>reliable detection of objects in the field of view of the LD-MRS</li> <li>high scanning range and compact housing</li> <li>simultaneous measurement on 8 planes</li> <li>LD-MRS HD: expanded penetration through dust by special receiver unit and extended dust filter software</li> </ul>
Safety and comfort for the user	<ul style="list-style-type: none"> <li>Rugged, compact aluminum housing also available as lightweight housing</li> <li>laser class 1, laser switches off in case of faults</li> <li>enclosure rating IP 69K in mounted condition</li> <li>upgradable by firmware update via data interface Ethernet</li> <li>low power consumption</li> <li>wide range of supply voltage</li> </ul>
Simple operation / parametrization	<ul style="list-style-type: none"> <li>Configuration of measuring mode using the SICK LaserView Customer Edition visualization tool with Windows and Linux</li> <li>And configuration of field monitoring using the SOPAS-ET the configuration software with Windows</li> <li>alternatively using commands in messages</li> </ul>
Operating states	<ul style="list-style-type: none"> <li>wait mode: Configuration of the LD-MRS</li> <li>Operating mode measurement: Scanning the field of view</li> <li>Operating mode "Object tracking". Scanning the field of view and tracking of up to 64 objects in field of view.</li> <li>Field monitoring mode: scanning the field of view and monitoring specific fields for changes (field intrusion)</li> </ul>
Output of results	<ul style="list-style-type: none"> <li>Measurements: via the Ethernet data interface</li> <li>Object tracking: pre-processed object data allows for object tracking of up to 64 objects simultaneously, as well as the output of their dynamic properties (e.g. speed, direction, size, etc.)</li> <li>Field violations: via a maximum of 10 external switch outputs with the help of two optional CAN modules (accessory) with eight configurable I/O ports each, optional arming of specific, freely-definable evaluation instances through 2 external switching inputs</li> </ul>
Electric interfaces	<ul style="list-style-type: none"> <li>power supply (9 to 27 V DC)</li> <li>Ethernet data interface</li> <li>Data interface CAN</li> <li>synchronization interface</li> <li>auxiliary data interface: RS-232</li> </ul>
Connection technology (type)	<ul style="list-style-type: none"> <li>connection "Ethernet": 4-pin socket (round plug-in connection)</li> <li>connection "Data interfaces/synchronization": 12-pin socket (round plug-in connection)</li> <li>connection "Power": 4-pin plug (round plug-in connection)</li> </ul>

Tab. 3-4: Product features and functions (overview)

### 3.3.2 Application

The LD-MRS detects objects.

Its applications are wide-ranging. In particular, the following can be stated:

- Container loading / handling
- Traffic / Transport
- Robots / UAV
- Collision protection
- Autonomous industrial vehicles
- Security monitoring
- Topography and urban surveying

In measuring mode, the measurements can be processed externally to identify and analyse objects.

In field monitoring, external switch outputs signal changes in the monitored areas (fields). Evaluation instances can be defined with an application-specific evaluation strategy per evaluation field and assigned to switch outputs and combined. Combining two switch outputs activates a specific evaluation instance only when needed.

The object tracking provides pre-processed object data. Up to 64 objects can be processed at the same time. Dynamic parameters such as direction, speed and even acceleration are available for every object. This data is available when vehicle data (ego motion data) is provided.

## 3.4 Operating principle of the device

The LD-MRS serves for contact-free and directional detection of the sensor surroundings, or rather of the objects located within the radial field of view.

The object detection is done with laser beams that the LD-MRS emits in four stacked planes. The device measures the distance and the direction (the angle to the LD-MRS) of the object. From the measured data, the LD-MRS calculates the position of the object in the sensor co-ordinate system.

The resulting profiles of the different planes are called scan, see [Chapter 3.5 Measuring mode, Page 36](#).

The LD-MRS issues the measured data in reference to its sensor co-ordinates. The data contain information about the measuring plane, distance, echo number, echo pulse width and class. It also contains angle information (horizontal and vertical).

Due to the detailed presentation and thus the extensive amount of data, the LD-MRS issues the measured data via the Ethernet interface only.

The factory defaults of the LD-MRS are designed to facilitate immediate commissioning of the LD-MRS. The user can modify some parameters to optimize the LD-MRS in regard to the application at hand.

### 3.4.1 Measuring process and measuring properties

The LD-MRS is a measurement instrument basing on the Time-of-Flight (ToF) technology, i. e. the LD-MRS uses laser beams to detect distance and angle of objects.

It radially scans the surroundings with laser beams deflected by a rotating mirror, receives the echos with a photo diode receiver and outputs the data processed based on a runtime calculation via the Ethernet interface.

By the permanent rotation of the mirror in connection with the laser beam, it is possible to build a complete profile of the surroundings within the field of view of the LD-MRS. The scan data of the LD-MRS consist of values for distance, angle, and echo pulse width.

The measurement properties base on

- time-of-flight measurement,
- multi-echo capability,
- multi-layer technology,
- the scanning range and the relation of angle to range,
- the angular resolution and the scanning frequency
- the preprocessed and filtered data.

### 3.4.2 Time-of-flight measurement

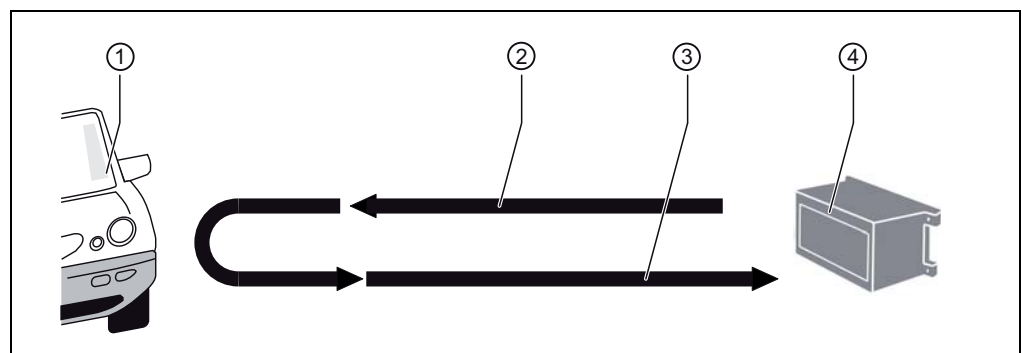

Fig. 3-2: Principle of time-of-flight measurement

Caption:

- 1 Object
- 2 Laser pulse, transmitted
- 3 Laser pulse, reflected
- 4 LD-MRS

The laser pulses emitted from the LD-MRS are reflected by the objects in the surroundings. The LD-MRS collects the laser pulse reflections, processes the information and issues the data via the Ethernet interface.

The distance is calculated from the time-of-flight of the laser pulse and the speed of light.

The rotating mirror deflects the laser pulses. The angular position of the mirror during deflection yields the direction of the detected object.

The combination of these values builds the basis for a complete profile of the surroundings in the radial scanning range of the LD-MRS.

3.4.3 Multi-echo capability

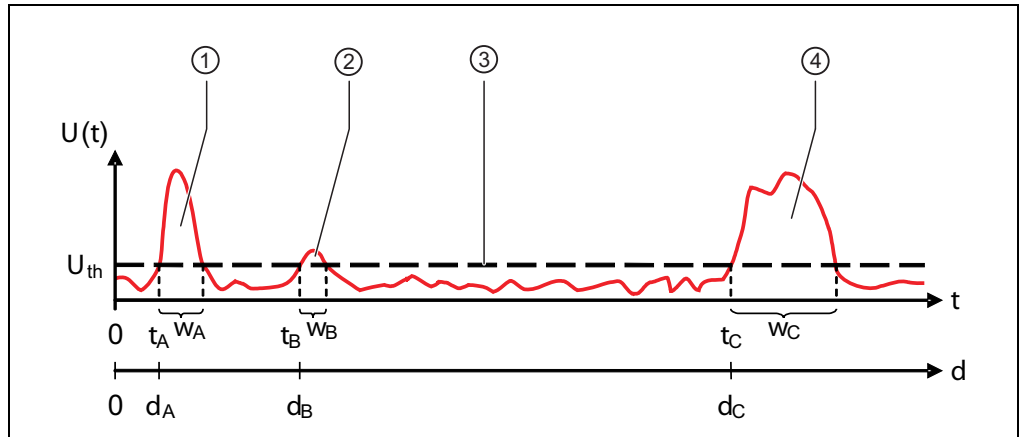

Fig. 3-3: Multi-echo capability

Caption:

- 1 Example: echo of a window pane
- 2 Example: echo of a raindrop
- 3 Threshold voltage
- 4 Example: echo of an object

- V(t) input voltage
- t time
- d distance
- w echo pulse width
- A glass panel
- B rain drop
- C object
- V<sub>th</sub> threshold voltage

The LD-MRS has multi-echo capability.

Thus, it can gather and evaluate up to three echoes per transmitted laser pulse.

Once the echo reaches the photo diode receiver of the LD-MRS, the received intensity is transformed into a voltage.

In the example shown in Fig. 3-3, a reflected echo of a glass pane yields a high voltage over a short period of time.

The echo of a rain drop, however, yields a very low voltage over a short period of time.

The echo of an object yields a high voltage over a longer period.

All three echoes are generated by reflections of a single transmitted pulse.

The threshold voltage V<sub>th</sub> separates the system noise from the relevant echoes. By comparing, this threshold prevents system noise to be evaluated as measured value.

The LD-MRS uses the amplitudes above the threshold voltage V<sub>th</sub> to evaluate the echo pulse widths w<sub>A/B/C</sub> in that range.

3.4.4 Multi-layer technology

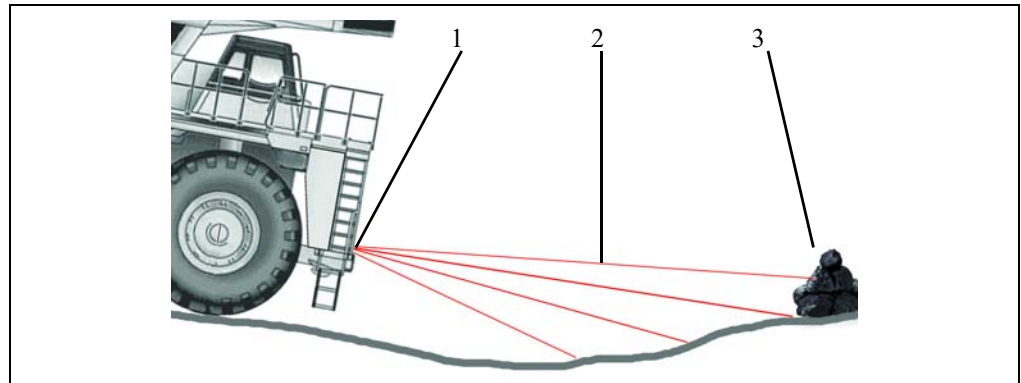

Fig. 3-4: Multi-layer technology

Caption:

- 1 LD-MRS
- 2 Scan plane
- 3 Object

The multi-layer technology of the LD-MRS allows for a pitch angle compensation by means of four scan planes with different vertical angles, e.g. if the device is mounted to a vehicle. Thus, the LD-MRS detects the object reliably even when accelerating or braking the vehicle.

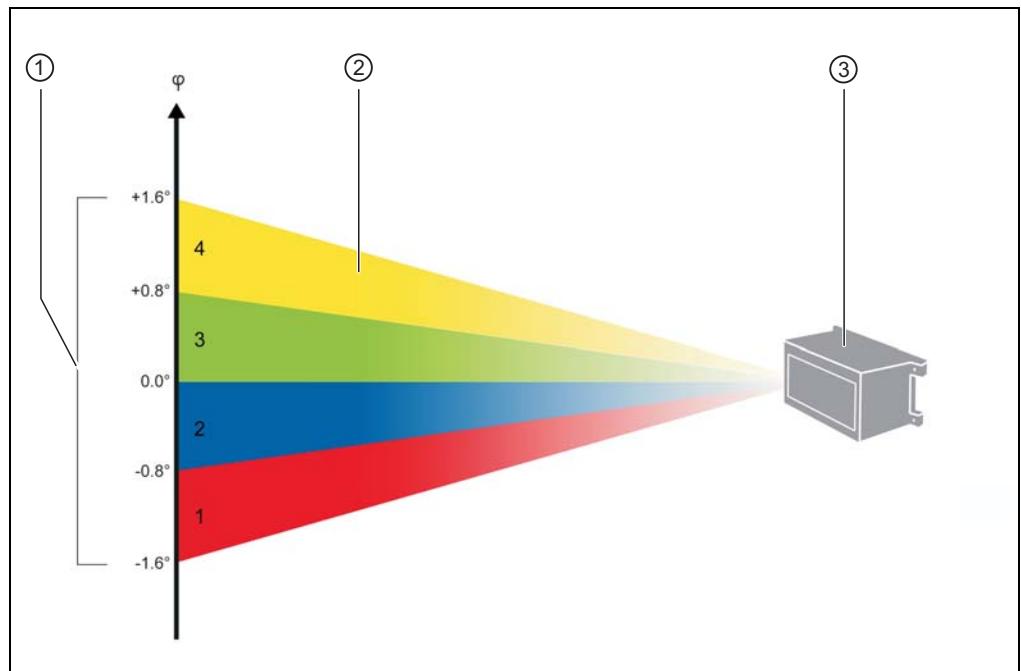

Fig. 3-5: Principle of the scan planes, color-coded

Caption:

- 1 Vertical aperture angle
- 2 One of the four scan planes
- 3 LD-MRS



The photo diode receiver of the LD-MRS consists of four independent receivers arranged in a line.

These four receivers enable the implementation of the multi-layer technology.

One receiver is assigned to each plane, thus dividing the vertical aperture angle into four scan planes.

These four scan planes are scanned interlaced. This means that the combination of two planes is always scanned simultaneously (first e. g. the yellow and the green plane, then the blue and the red plane), see [Chapter 3.4.8 Angular resolution and scanning frequency, Page 29](#).

Plane	Echo 1	Echo 2	Echo 3
yellow	scan plane 4	scan plane 4	scan plane 4
green	scan plane 3	scan plane 3	scan plane 3
blue	scan plane 2	scan plane 2	scan plane 2
red	scan plane 1	scan plane 1	scan plane 1

Tab. 3-5: Naming conventions (colour code see [Fig. 3-5](#))

Colour hues visualize the planes and colour saturation of the echoes. [Tab. 3-5](#) illustrates the naming convention for the planes and their predefined colors that are used for the visualization. The colour saturation in the visualization decreases from echo to echo.

**Example for a case with three echoes, see [Fig. 3-3](#)**

If a laser beam hits a glass pane, for example, a part of the light is reflected and triggers a measurement (echo 1).

Most of the light passes the window pane and might hit a rain drop which then again reflects a part of the light (echo 2).

The remaining light is then reflected by an object, which then results in the third measured value (echo 3).

### 3.4.5 Scanning range and relation of angle to range

#### Scanning range

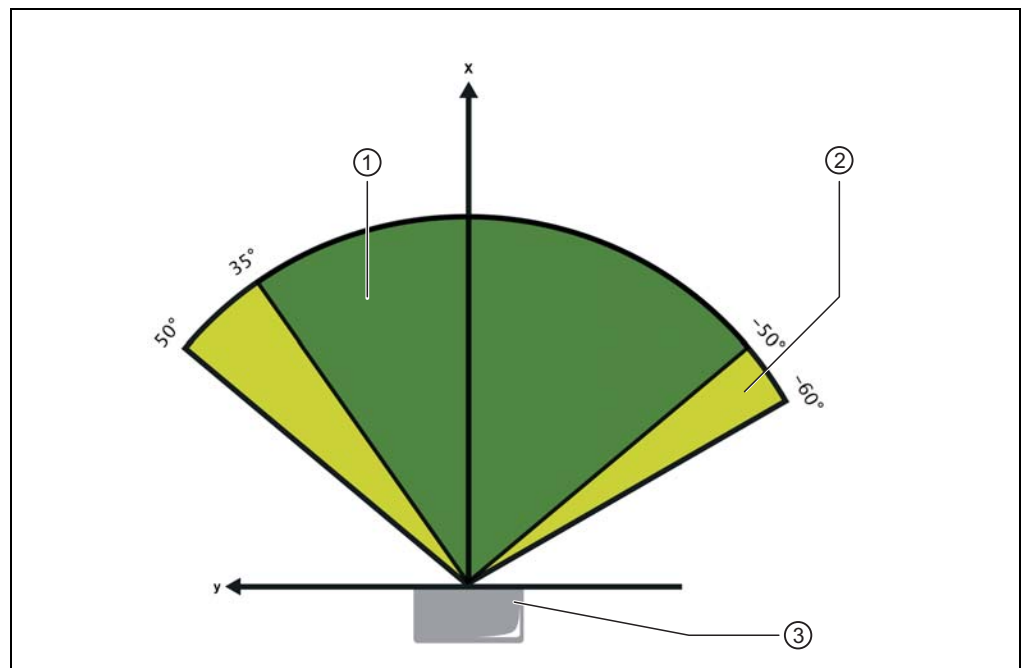

Fig. 3-6: Scanning range

#### Caption:

- 1 central working range (green)
- 2 lateral scanning range (light green)
- 3 LD-MRS

The LD-MRS has been designed with a central scanning range of 85° for four scan planes. The scanning range can be extended between +35° and +50° or -50° and -60° to a total range of 110°. The lateral scanning ranges only provide two instead of four scan planes.

Relation of angle to scanning range

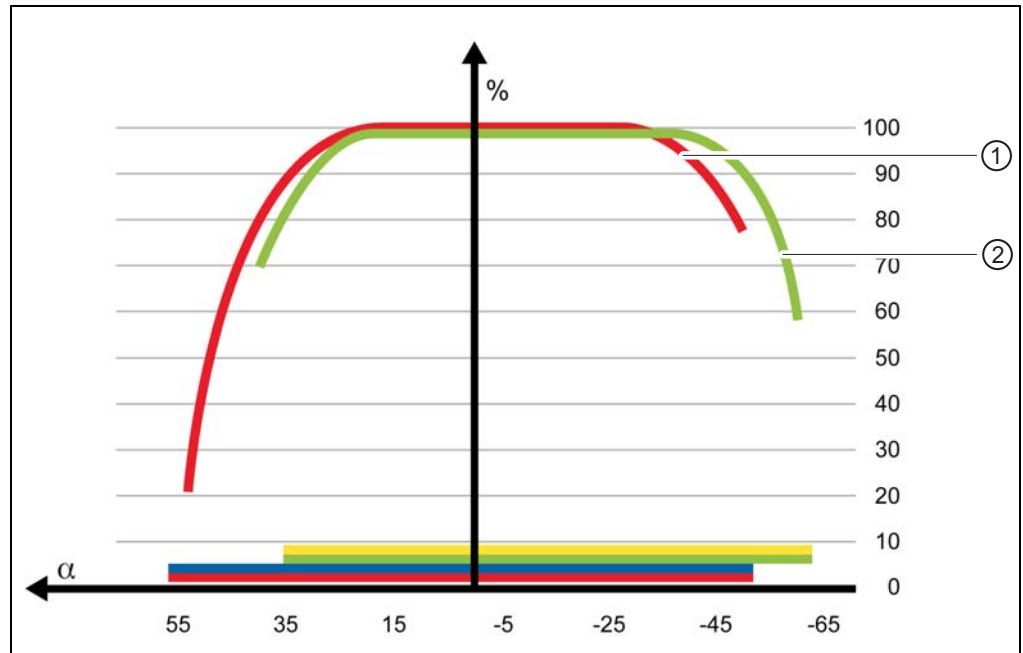

Fig. 3-7: Relation of angle to scanning range

Caption:

1 Curves of the upper planes (scan planes 1 and 2)

2 Curves of the lower planes (scan planes 3 and 4)

%scanning range in %

$\alpha$  angle in °

Due to the optical design of the LD-MRS, the scanning range depends on the angle, see [Fig. 3-7](#).

The LD-MRS HD and the LD-MRS differ marginally in regard to the way the scanning range depends on the angle.

### 3.4.6 Sensing range in relation to remission

The following table [Fig. 3-7](#) of the LD-MRS and LD-MRS HAD shows the sensing range in relation to the remission.

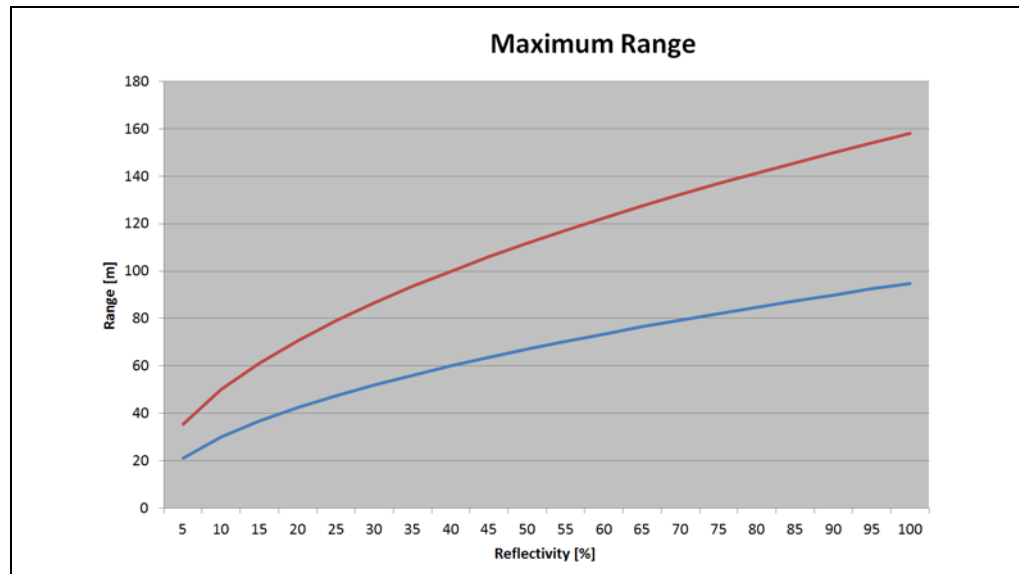

Fig. 3-8: Sensing range in relation to remission

### 3.4.7 Filter

#### Noise filter

The noise filter reduces the effects of atmospheric interference such as rain, spray or dust with a clutter filter. This filter classifies the scanning data and distinguishes normal measurements from noise.

The filter affects the field evaluation and the output measurements.

The LD-MRS has for scan planes (layers). Every second measurement within a layer takes place at close range up to approximately 15 m (49.2 ft) with reduced sensitivity. For greater distances, the measurements are taken at normal sensitivity. In addition, the measurements are evaluated. Criteria such as proximity relationships between measurements with normal sensitivity as well as the measuring characteristic of the sensor are taken into account.

When the filter is set, measurements classified as clutter are not transmitted to the SOPAS-ET interface and are therefore not included in the field evaluation.

**Important** The close range sensitivity is reduced by the clutter filter. Consequently, targets with a lower remission are more difficult for the LD-MRS to identify.

#### Only the last echo

This filter causes only the last echo of a laser pulse to be measured. If for example part of the energy is reflected as a first or second echo by a pane of glass or raindrop, only the last echo of the actual object is measured. The filter affects the field evaluation and the output measurements.

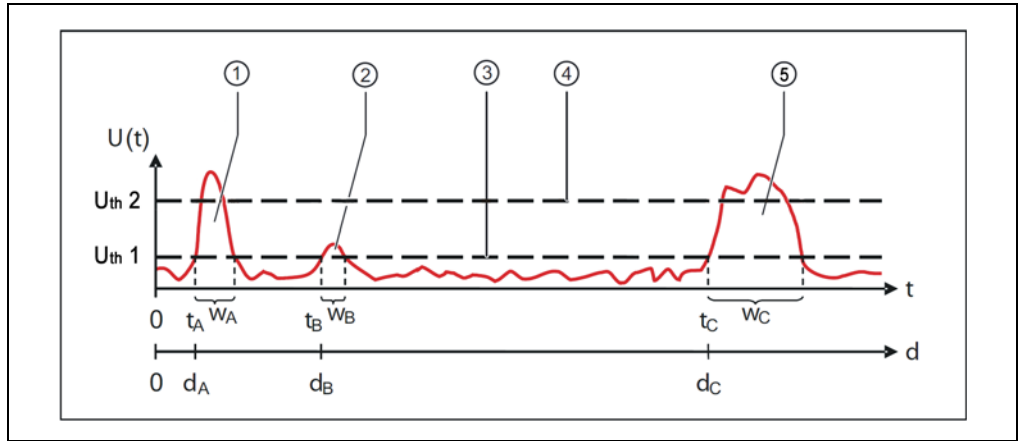

Fig. 3-9: Example of three echoes of a laser pulse

Caption:

1. Echo of a pane of glass
2. Echo of a raindrop
3. Threshold voltage 1
4. Threshold voltage 2
5. Echo of an object

### 3.4.8 Angular resolution and scanning frequency

The LD-MRS can be operated with three different scanning frequencies (12.5 Hz, 25 Hz and 50 Hz), which allow four different settings of the angular resolution.

The operator can configure these parameters.

#### Angular resolution

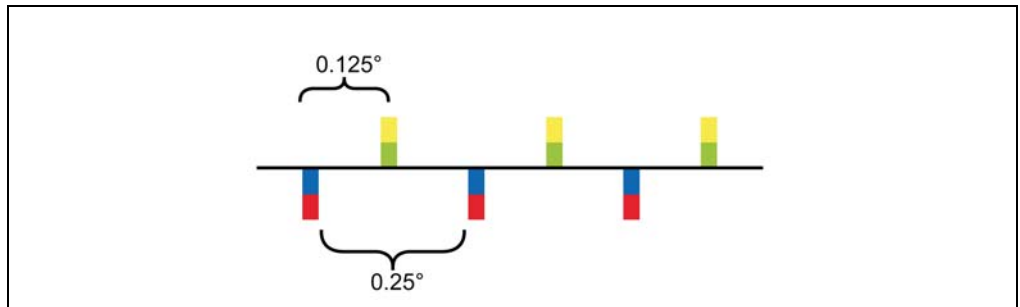

Fig. 3-10: Angular resolution

Two scan planes each are measured and analysed simultaneously. If an angular resolution of  $0.125^\circ$  is specified for a certain range, then  $0.125^\circ$  is the angular step between two scan planes (e. g. red-blue) and their partners (e. g. yellow-green). The angle for the next measurement on the same plane is twice as high, in this example  $0.25^\circ$ .

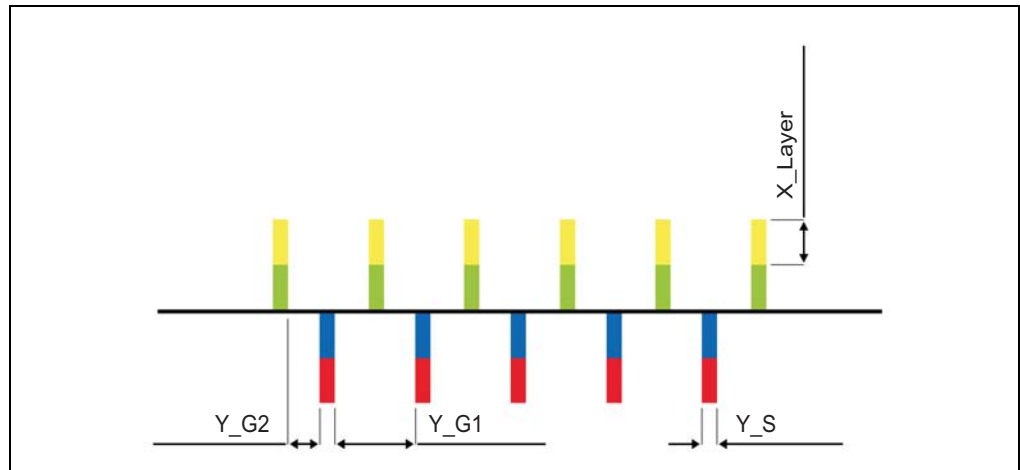

Fig. 3-11: Example: Angular resolution of 0.25° at distance d = 25 m (82 ft)

Caption:

Y\_G1 distance between measured points in one measurement plane (here: Y\_G1 = 0.1833 m)

Y\_G2 distance between measured points between two laser pulses (here: Y\_G2 = 0.0742 m)

Y\_S width of measured point (here: Y\_S = 0.0349 m)

X\_Layer height of individual measured point (here: X\_Layer = 0.3491 m)

The following tables illustrate some values as examples:

Distance d [m]	Y_S [m]	Y_G1 [m]	Y_G2 [m]	X_Layer [m]
10	0.0140	0.0297	0.0079	0.1396
25	0.0349	0.0742	0.0196	0.3491
50	0.0698	0.1484	0.0393	0.6981
100	0.1396	0.2967	0.0785	1.3963

Tab. 3-6: Angular resolution 0.125°

Distance d [m]	Y_S [m]	Y_G1 [m]	Y_G2 [m]	X_Layer [m]
10	0.0140	0.0733	0.0297	0.1396
25	0.0349	0.1833	0.0742	0.3491
50	0.0698	0.3665	0.1484	0.6981
100	0.1396	0.7330	0.2967	1.3963

Tab. 3-7: Angular resolution 0.25°

Distance d [m]	Y_S [m]	Y_G1 [m]	Y_G2 [m]	X_Layer [m]
10	0.0140	0.1606	0.0733	0.1396
25	0.0349	0.4014	0,01833	0.3491
50	0.0698	0.8029	0,3665	0.6981
100	0.1396	1.6057	0,7330	1.3963

Tab. 3-8: Angular resolution 0.5°

In measuring mode for a scanning frequency of 12.5 Hz, you can choose between an angle resolution that is constant or changes according to sector (settable with the SICK LaserView Customer Edition). This function is not possible for field monitoring.

The scanning frequencies of 25 Hz and 50 Hz only allow for constant angular resolution.

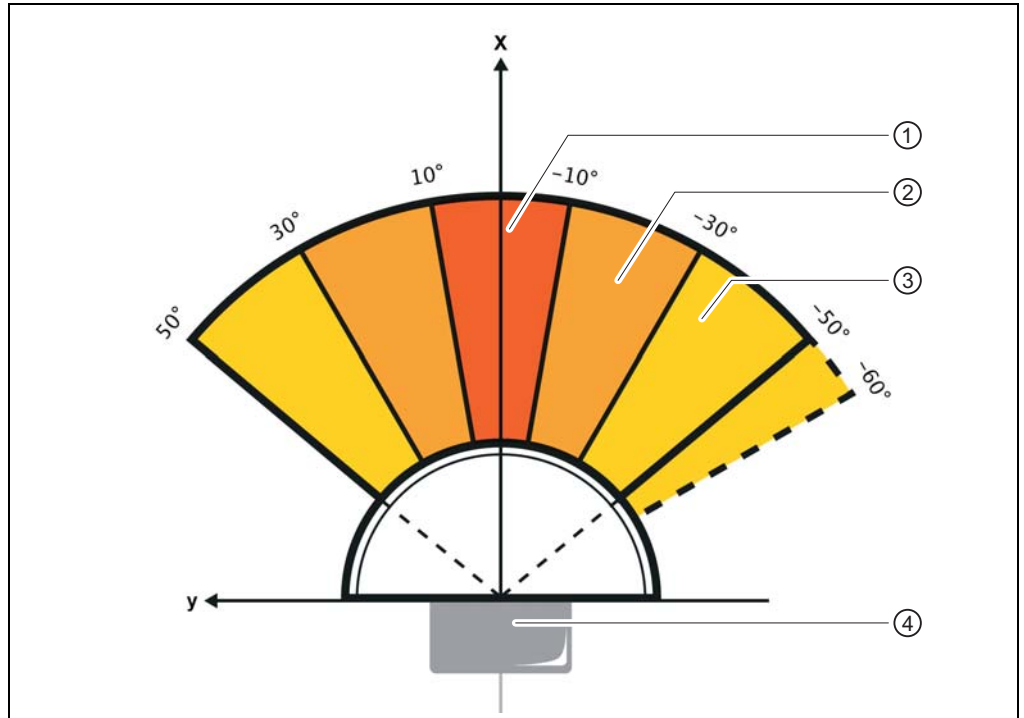

Fig. 3-12: Different angular resolution by sector

Caption:

- 1 Central area of the angular resolution  $0.125^\circ$
- 2 Middle area of the angular resolution  $0.25^\circ$
- 3 Lateral area of the angular resolution  $0.5^\circ$
- 4 LD-MRS

The focus of the angular resolution is in an area of  $\pm 10^\circ$  (central area) around x-axis of the sensor.

A slightly lesser angular resolution is applied in the medium area of  $\pm (30^\circ \text{ to } 10^\circ)$  around the x-axis.

The lateral area from  $+50^\circ$  to  $+30^\circ$  and  $-30^\circ$  to  $-60^\circ$  has a lower angular resolution because the objects there are less relevant.

**Scanning frequency 12.5 Hz**

Fig. 3-13: Scanning frequency 12.5 Hz with constant angular resolution of  $0.125^\circ$  (only devices LD-MRSxxx.S01) or  $0.25^\circ$

At the scanning frequency 12.5 Hz with constant angular resolution, the angular resolution is  $0.25^\circ$  (devices LD-MRSxxx.S01:  $0,125^\circ$ ), see [Fig. 3-13](#).

**Scanning frequency 25 Hz**

Fig. 3-14: Scanning frequency 25 Hz with constant angular resolution of  $0.25^\circ$

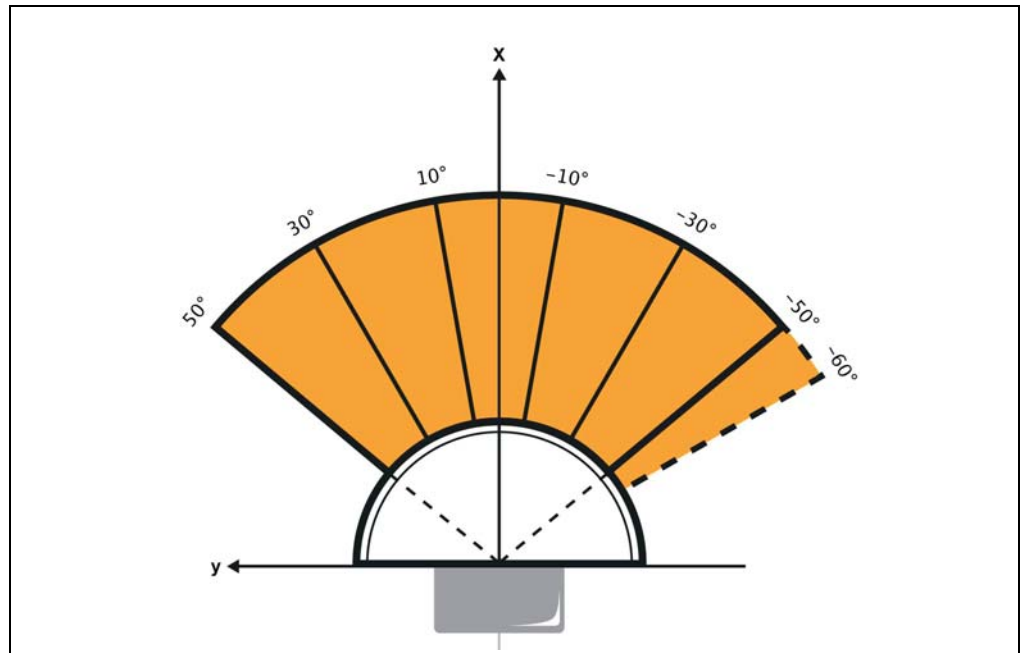
At the scanning frequency 25 Hz with constant angular resolution, the angular resolution is  $0.25^\circ$ , see [Fig. 3-14](#).

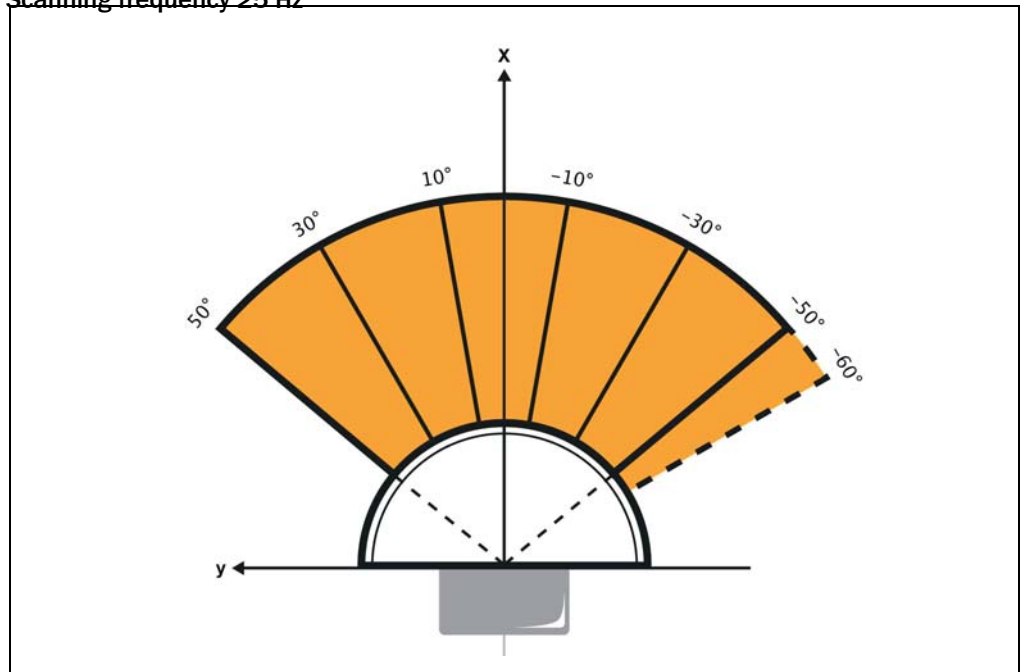

LD-MRS

## Scanning frequency 50 Hz

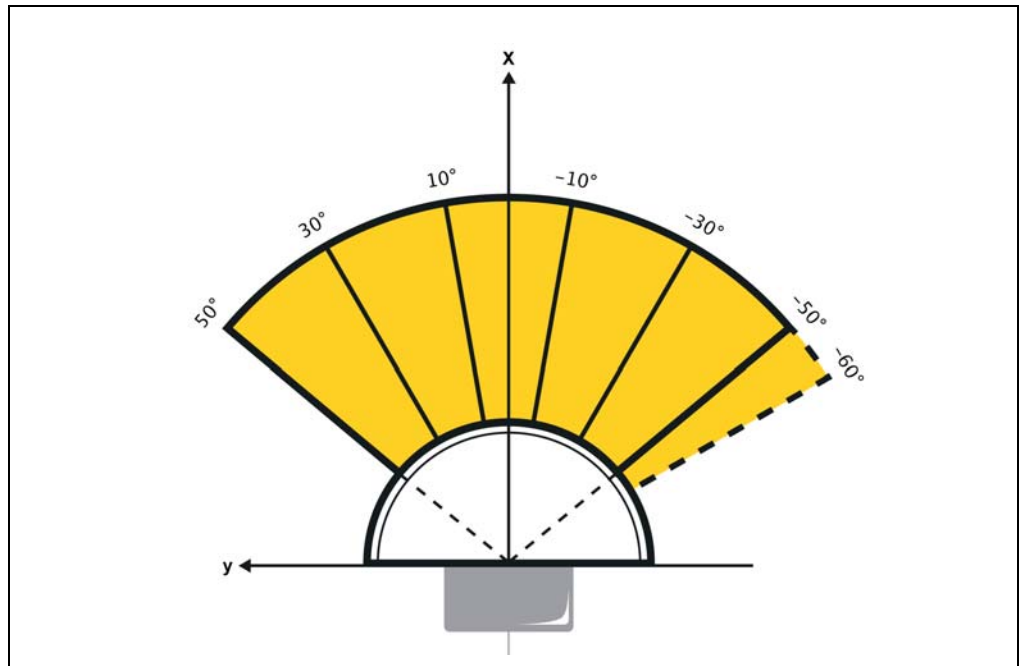

Fig. 3-15: Scanning frequency 50 Hz with constant angular resolution of  $0.5^\circ$

At the scanning frequency 50 Hz with constant angular resolution, the angular resolution is  $0.5^\circ$ , see [Fig. 3-15](#).

### 3.4.9 Impact of the object surface on the measurement

The signal received from a perfectly diffuse reflecting white surface corresponds to the definition of a remission of 100 %. As a result of this definition, the remissions for surfaces that reflect the light bundled (mirrored surfaces, reflectors), are more than 100 %.

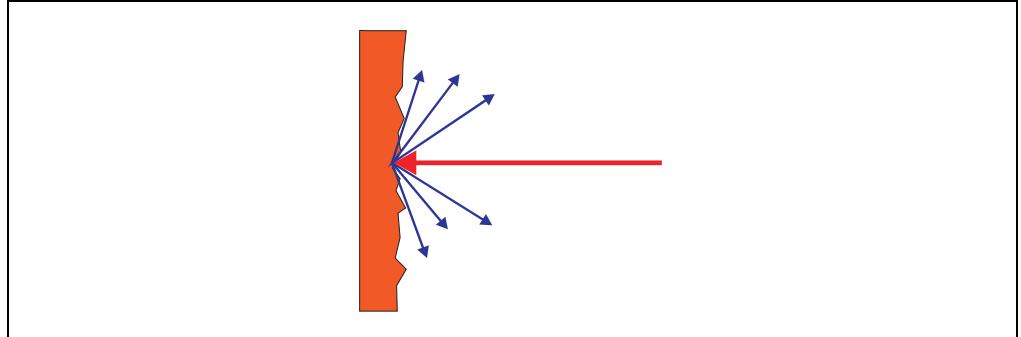

Fig. 3-16: Reflection of the laser beam at the surface of an object

Most surfaces reflect the laser beam diffusely in all directions.

The reflection of the laser beam will vary as a function of the surface structure and colour. Light surfaces reflect the laser beam better than dark surfaces and can be detected by the LD-MRS over larger distances. Brilliant white plaster reflects approx. 100% of the incident light, black foam rubber approx. 2.4 %. On very rough surfaces, part of the energy is lost due to shading. This reduces the scanning range of the LD-MRS.

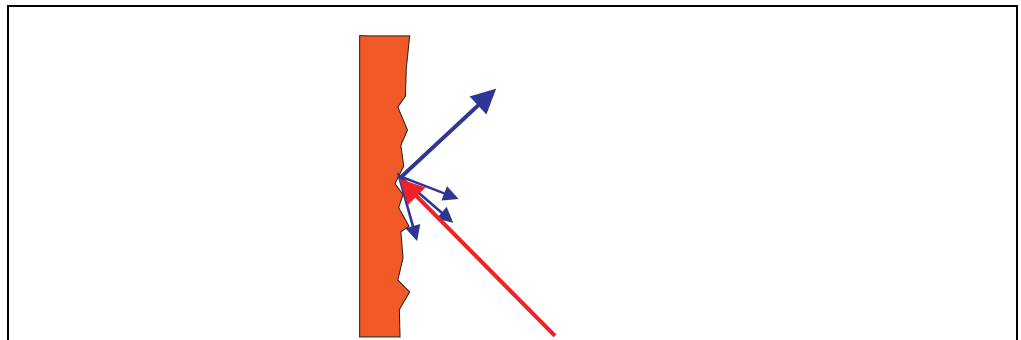

Fig. 3-17: Reflection angle

The reflection angle is the same as the angle of incidence. If the laser beam is incident perpendicularly on a surface, the energy is optimally reflected, see Fig. 3-17. If the beam is incident at an angle, a corresponding energy and scanning range loss is incurred.

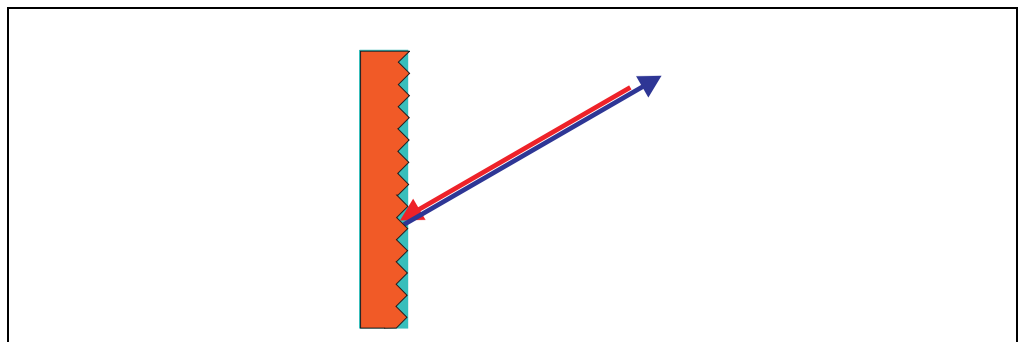

Fig. 3-18: Degree of reflection

If the reflected energy returned is over 100% (basis: Kodak standard) the incident beam is not reflected diffusely in all directions, but is reflected in a specific direction. As a result a

large portion of the energy emitted can be received by the laser distance measurement device. Plastic reflectors ("cats' eyes"), reflective tape and triple prisms have these properties.

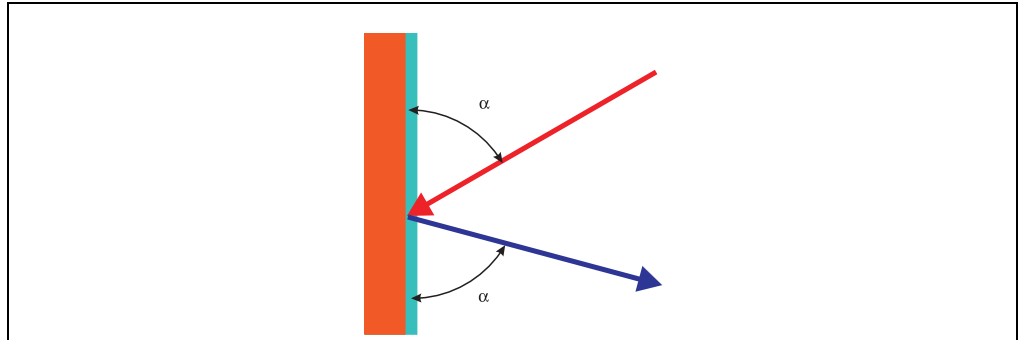

Fig. 3-19: Mirror surfaces

At mirror surfaces the laser beam is almost entirely deflected, see [Fig. 3-19](#).

Instead of the surface of the mirror, it is possible that the object on which the deflected laser beam is incident may be detected.

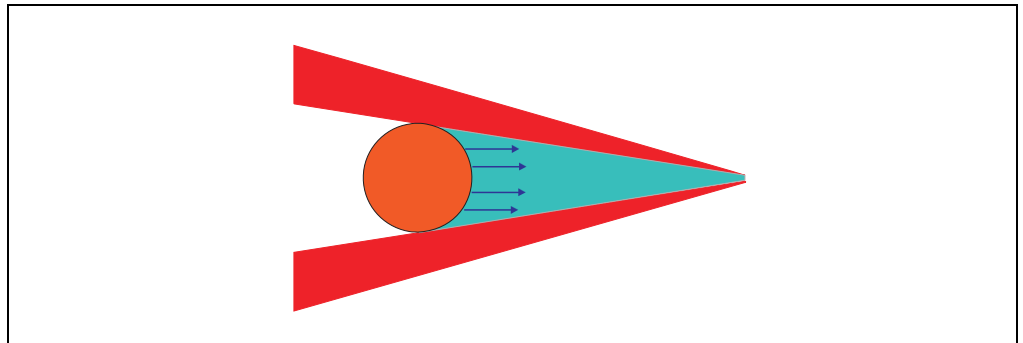

Fig. 3-20: Object smaller than diameter of the laser beam

Objects that are smaller than the diameter of the laser beam cannot reflect all the energy of the laser light, see [Fig. 3-20](#). The energy in the portion of the laser light that is not reflected is lost. This means that the scanning range is less than would be possible theoretically based on the surface of the object.

### 3.4.10 Data interface

The LD-MRS has an Ethernet interface for configuration and data transmission for measuring mode.

The Ethernet interface is designed as TCP/IP interface; it supports full duplex.

By factory default, the Ethernet interface is configured as follows:

- IP address: 192.168.0.1
- Subnet mask: 255.255.255.0
- TCP port: 12002

Depending on the configuration of the LD-MRS, the Ethernet interface provides different data types:

- Scan data (see [Chapter 3.5 Measuring mode, Page 36](#))
  - LD-MRS: data type 0x2202
- Warnings and fault messages
  - LD-MRS: data type 0x2030
- Commands and responses
  - data types 0x2010 and 0x2020

For a description of the electrical connections and cables of the data interfaces, refer to [Chapter 5.3 Electrical connections and cables, Page 66](#).



See Ethernet Data Protocol for further information.

## 3.5 Measuring mode

### 3.5.1 Scan data

Scanning the sensor surroundings within the scanning range of the LD-MRS is called the scan process.

The total set of measured data (= scan data) of a scan process, consisting of individual scan points, are called scan.

Upon request, the LD-MRS issues the scan data via the Ethernet interface.

In the scan process, the transmitted laser pulses are reflected by objects within the measurement range. These echo pulses are received and analysed by the LD-MRS. Every detected echo pulse is represented by a scan point with the following main properties:

- position of the point
- width of the echo pulse
- scan plane and echo number

The LD-MRS generates a two-dimensional profile of the surroundings, with additional height information (three-dimensional information) resulting from the multi-layer technology, see [Fig. 3-4, page 24](#).

Typical presentation of the scan data is a bird's view, i.e. the view from above onto the measurement plane.

### 3.5.2 Measured value output

For the measured value output, the LD-MRS supplies measured values to the Ethernet interface.

It is prerequisite for this data output that the LD-MRS is in the measurement mode. Normally, the LD-MRS starts measurement mode via the automatic power system. If the LD-MRS stops during measured value output, there are two ways to start the measurement mode:

- Start using the SICK LaserView Customer Edition visualization tool
- Start using a telegram, see Telegram Listing Ethernet Data Protocol, art. no. 8014492.

### 3.5.3 Data communication using messages

In measuring mode, the LD-MRS communicates with a connected computer using messages via the Ethernet interface.

The following functions can be run using messages:

- request for measured values by the PC and subsequent output of the measured values by the LD-MRS to the PC
- Setting the parameter using a computer to configure the LD-MRS
- parameters and status log querying by the PC

A detailed list of all possible telegrams is included the Telegram Listing Ethernet Data Protocol, art. no. 8014492.

### 3.6 Object Tracking (LD-MRSxxxx.S01 only)

By means of object tracking, the LD-MRS outputs preprocessed data that can then be used for advanced applications. No additional hardware or software is required for object tracking.

The LD-MRS outputs the following dynamic object parameters in relation to the data for its own movement:

- Position of the object
- Speed of the object
- Size (length and width) of the object
- Direction of movement of the object
- Age (scans, time) of the object

The areas of application include:

- Navigation
- Collision prevention
- Monitoring

Object tracking allows up to 128 objects to be tracked at the same time. The object data is then processed in real time. This real-time data is output via an Ethernet interface.

### 3.6.1 Processing raw data

The raw data is processed in four stages during object tracking:

- Raw data
- Object contour
- Bounding box
- Object box

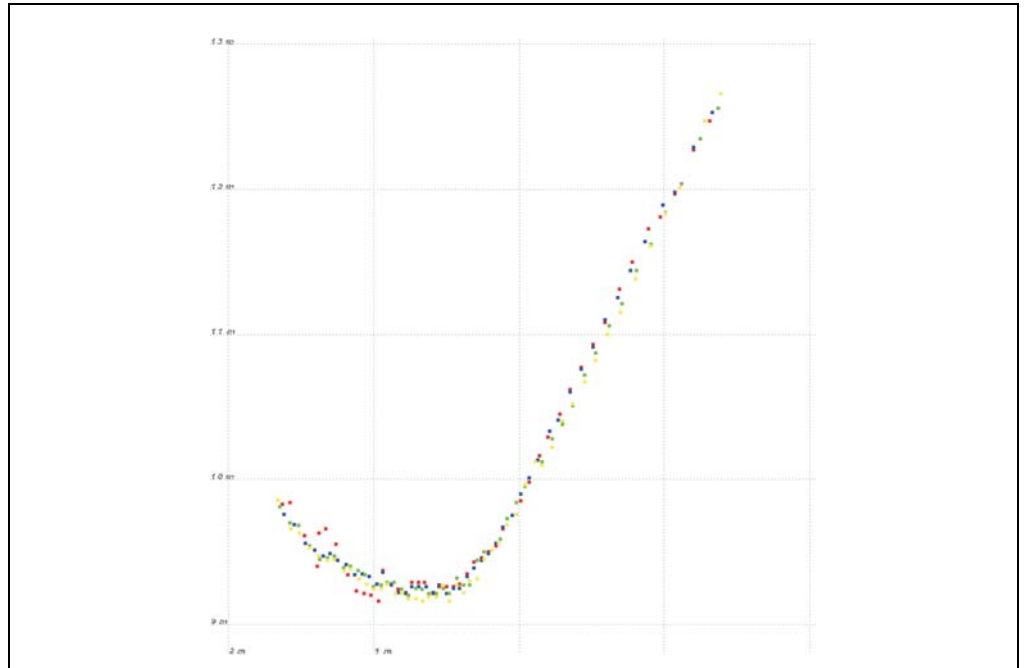

Fig. 3-21: Raw data

First, the LD-MRS analyzes the scan data. This analysis is referred to as preprocessing. During this process, the LD-MRS classifies every measured point and divides them up into values based on contamination, atmospheric disturbances (e.g. rain), and impact on the object.

The LD-MRS only outputs scan data as data types via the Ethernet interface.

It is important to note the following differences here:

Scan data from the LD-MRS is output within the sensor coordinates system in a diametrically opposed manner.

**Important** Scan data is transmitted from the LD-MRS within the sensor coordinates system.

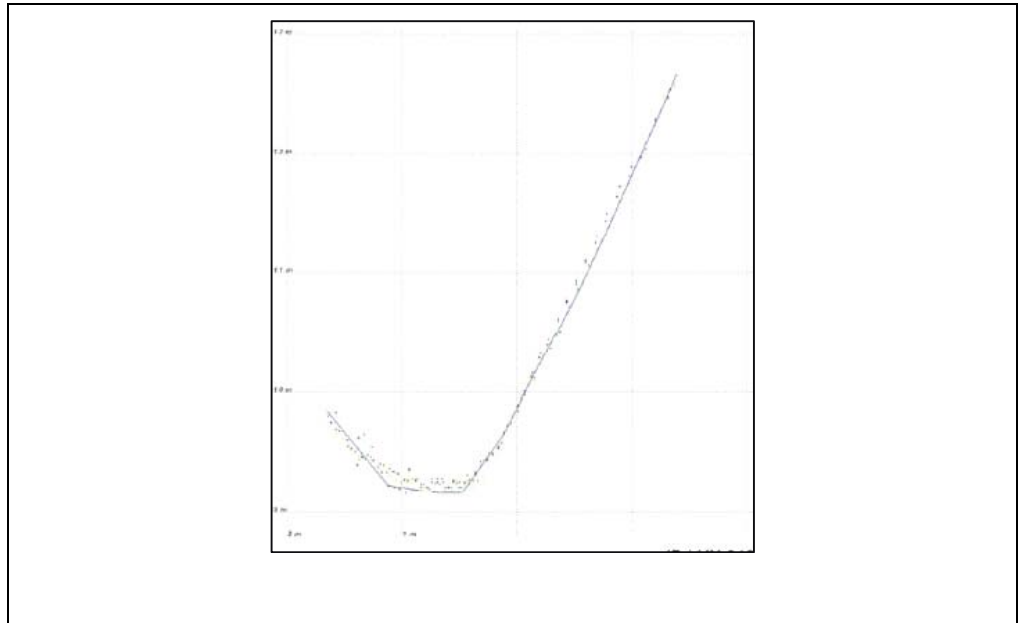

Fig. 3-22: Object contour  
When the "Show Contour" option is activated, the LD-MRS uses the raw data to generate an object contour. The scan data is divided to form groups consisting of related scan points. This division is dependent on the vehicle's own movement.

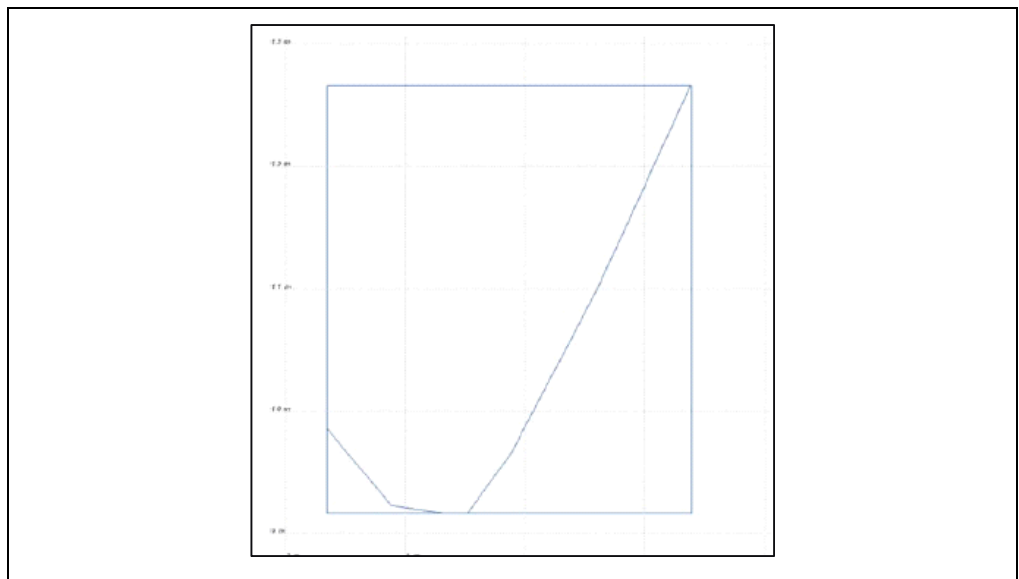

Fig. 3-23: Bounding box  
When the "Show Bounding Box" option is activated, the LD-MRS uses the raw data to generate a rectangular border around the object contour. The vehicle's own movement and the historical scan data will affect the object contour.



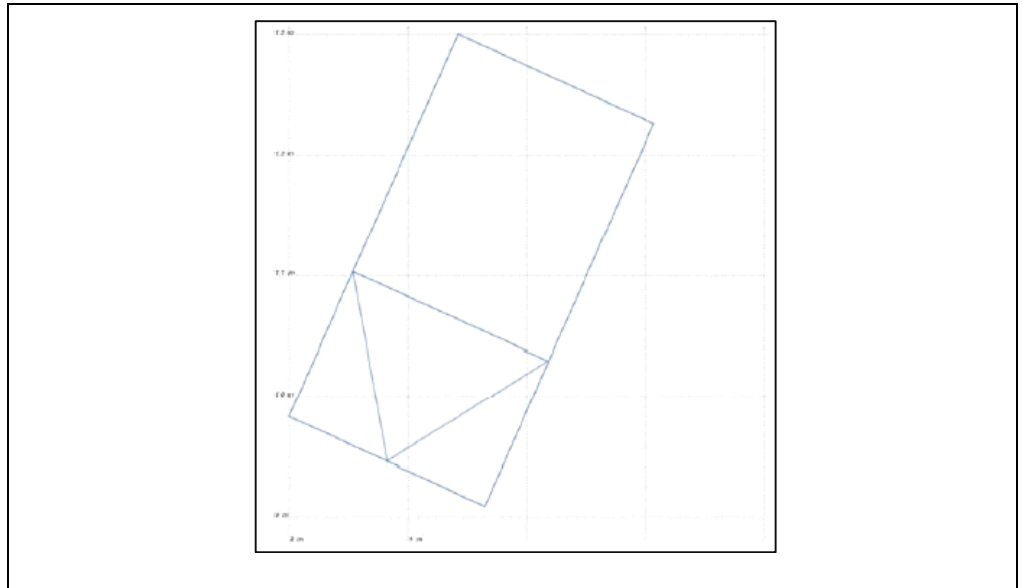

Fig. 3-24: Object

When the "Show Object Boxes" and "Show Direction" options are activated, the LD-MRS uses the raw data to generate a rectangular box around the object and also outputs the following data:

- Position of the object
- Speed of the object
- Size (length and width) of the object
- Direction of movement of the object
- Age (scans, time) of the object
- Contour of the object

#### Ego motion data:

It is possible to transfer information on the proper motion data of the vehicle to the LD-MRS. The scanner mounted on the vehicle passes on the data to the LD-MRS via Ethernet or CAN bus. This data is taken into account during object tracking and when calculating speed and direction properties of the detected objects. Without this information, the scanner assumes that its mounting/vehicle is not moving

### 3.6.2 „Suppressor filter“

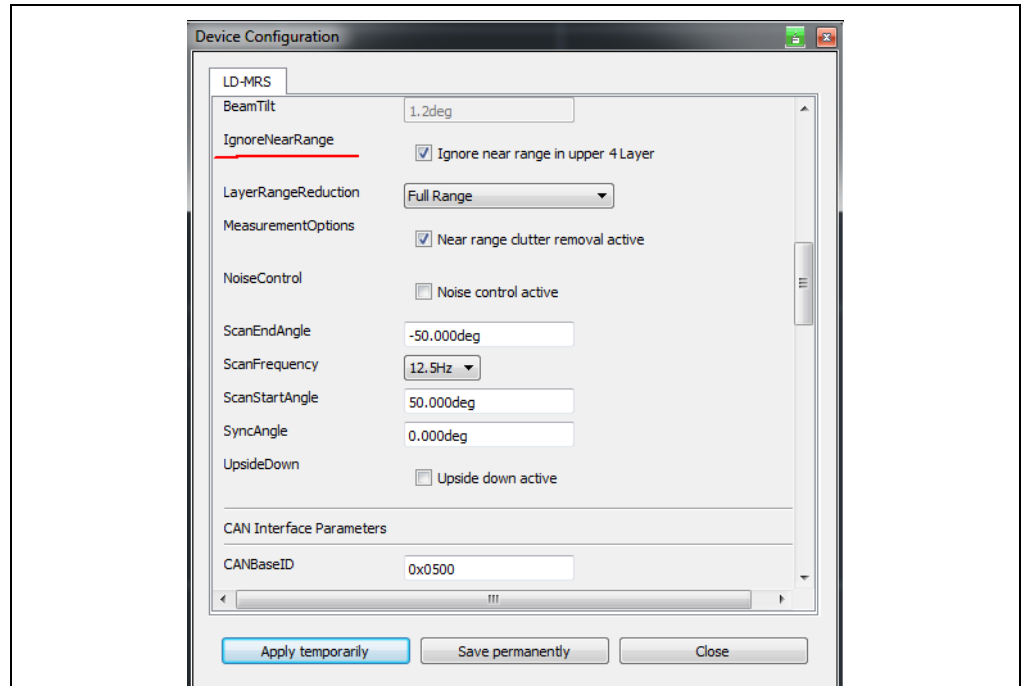

Fig. 3-25: „Suppressor“ filter

The "Suppressor" filter option can be activated during object tracking to improve the measurement results under difficult conditions. This filter reduces the sensitivity of the four lower levels to ensure more accurate measurement.

### 3.6.3 Reduced sensitivity

## NOTICE

If the sensitivity is reduced, the "NoiseControl" sensitivity setting will be deactivated because the reduction in sensitivity also results in excellent ambient light immunity.

If the "Lower 4 layers reduced range" option has been selected under the "LayerRangeReduction" setting, the measurements in the near range up to 15 m will not be used during object tracking.

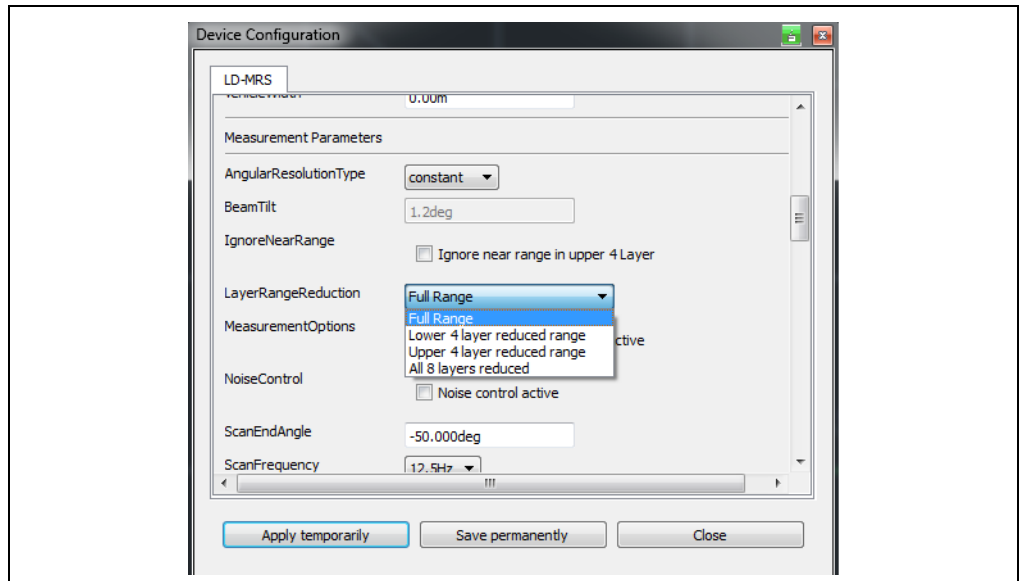

Fig. 3-26: Setting the near range sensitivity

Depending on the application, reducing the sensitivity can filter out erroneous measurements and prevent them from being taken in the first place. For use on a vehicle in a dusty environment, it is possible to reduce the sensitivity of the lower layers yet retain the full scanning range of the upper layers to make it possible to detect obstacles or objects that are further away.

Value	Upper layers	Lower layers	Application
0 (default)	Highest sensitivity	Highest sensitivity	Normal
1	Highest sensitivity	Reduced sensitivity	Vehicle in dusty environment
2	Reduced sensitivity	Highest sensitivity	Horizontal measurement, possible errors due to setting sun
3	Reduced sensitivity	Reduced sensitivity	Profile measurement with sun in background

Tab. 3-9: Setting the layer sensitivity

## NOTICE

**If the LD-MRS has been mounted upside down, make sure that the "Upper layers" and "Lower layers" columns are swapped over and that the "Upside down active" option has been activated.**

The sensitivity is generally reduced to 60% of the original scanning range.

### 3.6.4 Clutter Remover

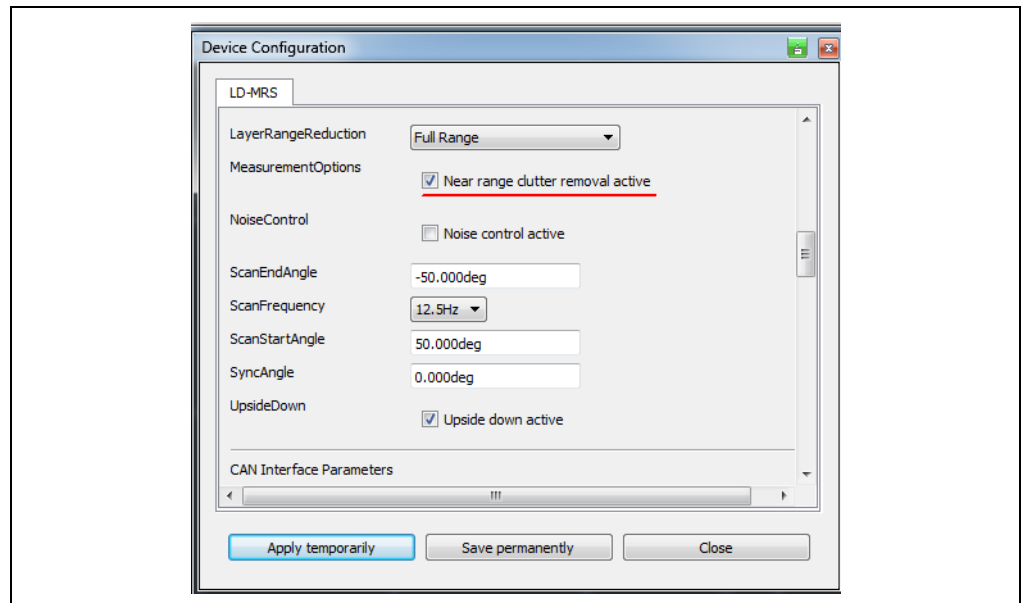

Fig. 3-27: Example for measurement result with „Clutter“

For every echo that reflects off an object, the signal amplitude is assessed twice – with a lower and higher threshold. If both thresholds are exceeded, it can be assumed that the measurement target is solid and fixed. If only the lower threshold is exceeded, the target is scattered:

For example, dust.

Within the output of measured values, the measured values are marked as "Clutter" and are not included in the object calculation

## NOTICE

This option should only be used in cases when it is known that there is a chance of disruptive measurements occurring in the measuring situation. If not, this may result in inaccurate measurement results.

### 3.6.5 „Noise Control“ filter

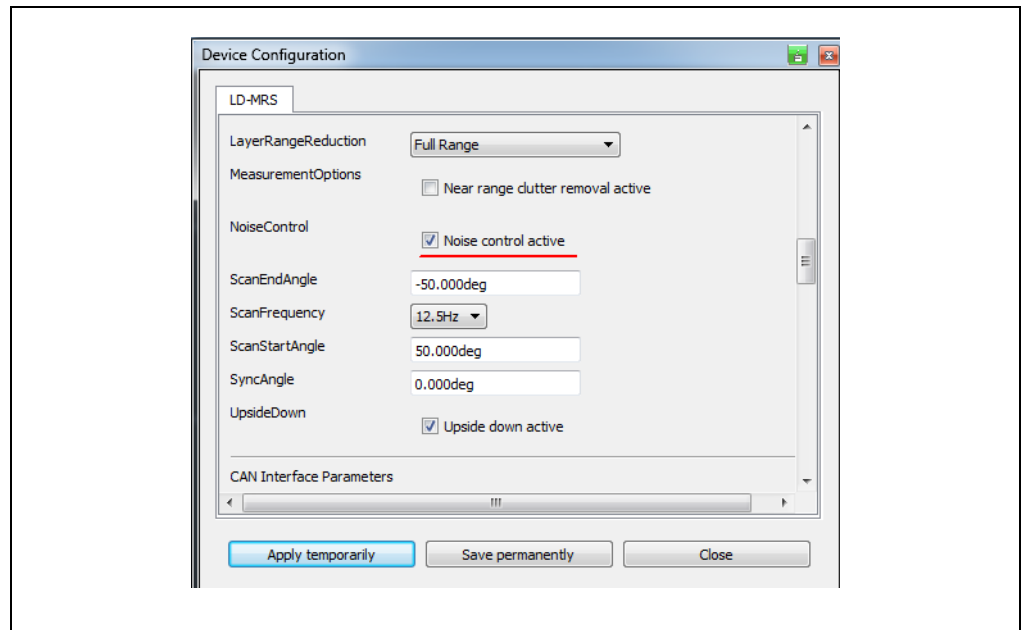

Fig. 3-28: „Noise Control“-Filter

The filter can only be used with the full range of layers ("Layer Reduction" > "Full Range"). In extreme cases of ambient light (e.g. sunlight), erroneous measurements may be taken, which can be evaluated and filtered by performing a plausibility check on a downstream external computer.

The "Noise control active" function activates an automatic sensitivity setting that monitors erroneous measurements at > 100 m and uses them to update the sensitivity of the receivers. The automatic sensitivity adjustment means that the scanning range will be between the maximum and the threshold for reduced sensitivity.

### 3.7 Mounting upside down (LD-MRS 8-Layer only)

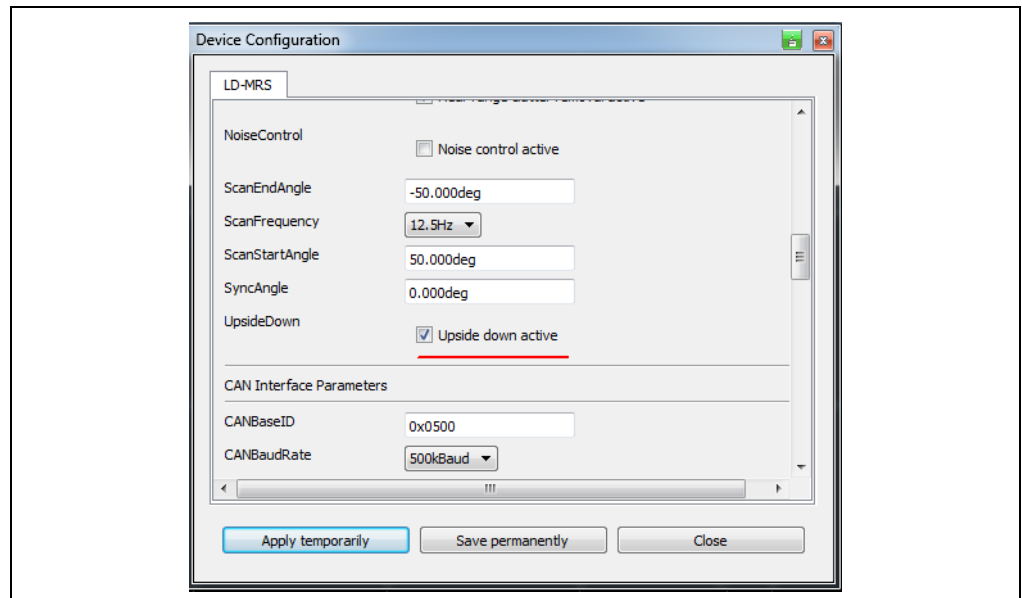

Fig. 3-29: Device parameter: Upside down mounting

If the LD-MRS has been mounted upside down, it is necessary to activate the "Upside down active" option. The installation position is selected from the Laserview/Telegram listing to ensure that the scan data output, coordinates and object data can be output correctly.

If two LD-MRS 8Ls are used, it is possible to extend the scanning range by mounting the LD-MRS 8L on the left-hand side, upside down in the direction of travel.

### 3.8 Field monitoring (for LD-MRS400xxx only)

With the aid of integrated field monitoring, the LD-MRS evaluates up to 16 evaluation fields within its scan range. It signals field violations (events) through a maximum of 10 logical outputs. The logical outputs can be assigned via the CAN bus to external, physical ports (that can each be configured as inputs or outputs) of a maximum of two CAN modules (optional accessory). A CAN module has 8 I/O ports.

Systems for collision protection, object protection or access monitoring can be created using field monitoring.

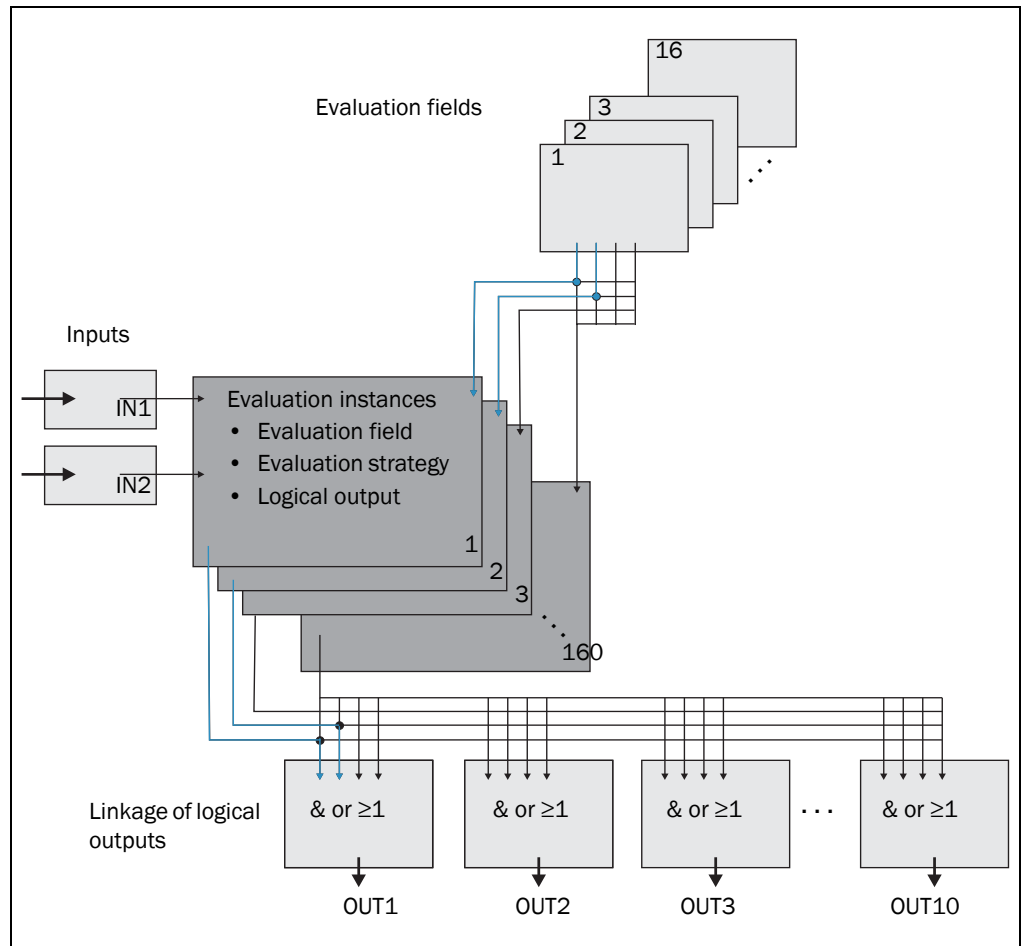

Fig. 3-30: Principle of field monitoring

The LD-MRS uses up to 16 evaluation cases to adapt to the evaluated situation. For each evaluation instance, and, the following are selected: one of 16 configurable evaluation fields, one evaluation strategy per field, a logical output and in certain circumstances a combination of the logical inputs that activate the evaluation instance. For each logical output, a link can be selected that determines the result of the output if more than one evaluation instance affects the output.

In the example in [Fig. 3-30](#), evaluation field 1 is used in evaluation instance 1, and evaluation field 2 is used in evaluation instance 2. Both evaluation instances affect logical output OUT1. If the results of the evaluation instances are AND-linked, the output only switches when both evaluation instances report results.

### 3.8.1 Evaluation instances

An evaluation instance determines which evaluation field is evaluated in which way (evaluation strategy), and which logical output it affects. Up to 16 evaluation instances can be configured, and all configured and evaluation instances are simultaneously active.

The following is specified with SOPAS-ET for each evaluation instance:

- Logical inputs that (specifically) activate the evaluation instance
- Associated evaluation field to be monitored
- Evaluation strategy per evaluation field
- Logical output that is affected by the evaluation instance
- Response time of the logical output
- Manipulation protection per evaluation field
- Reset behavior of an activated output

#### Logical inputs

If the evaluation instance is not to be continuously active, an input combination can be configured that activates the evaluation instance.

Input 1	Input 2	Evaluation instance
Active high	Active high	Evaluation instance 1
Active high	Active low	Evaluation instance 2
Active low	Active high	Evaluation instance 3
Active low	Active low	Evaluation instance 4

Tab. 3-10: Example of a combination of inputs

**Important** A combination of inputs can also be defined for several evaluation instances. In this case (for example), two evaluation instances are active simultaneously.

#### Evaluation strategy for evaluation field

The LD-MRS offers three different evaluation strategies:

- Pixel evaluation  
The LD-MRS evaluates the entire area of the field; each beam is used for evaluation. If an object enters the field, this event is transmitted to the appropriate output.
- Hiding  
The LD-MRS evaluates the entire area of the field. Objects up to a certain size can be hidden. An object is only identified when it is larger than the configured hidden size.
- Contour  
The LD-MRS evaluates the presence of a contour that is supposed to be continuously and completely in the evaluation field. This allows the LD-MRS to determine that for example a door is opening outward, or that the position of the LD-MRS is changing. In addition, the entrance of a vertical evaluation field or the deflection of the laser beam with a mirror can be identified.  
By using the hiding function, the absence of a part the contour can be hidden up to a certain size.



### Response time

A response time is defined for the above evaluation strategies. In order for the LD-MRS to identify an object, it must be detected at one location for the duration of the response time when the "pixel evaluation" and "hiding" evaluation strategies are used. With the "contour" evaluation strategy, the contour violation must be detected for at least the duration of the response time at one location.

### Manipulation projection

When evaluation fields are defined at a distance from the LD-MRS, a small, close-range object (between the LD-MRS in the field) may cast a large shadow in the observed fields. Without manipulation protection, shadowed objects are not detected in the field. When manipulation protection is activated, the LD-MRS signals a field violation when the shadowed area is larger than the configured minimum object size, and the configured "expanded response time" has passed.

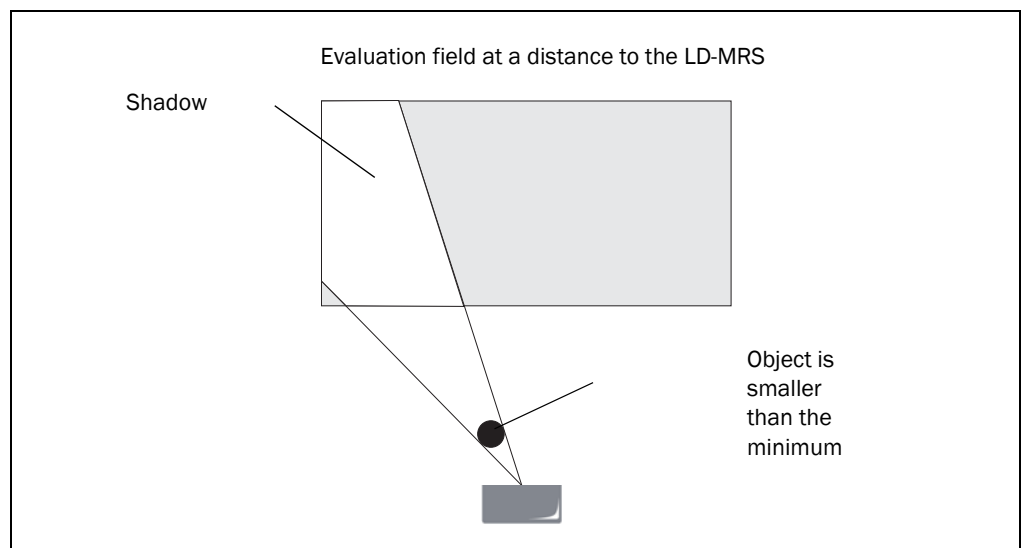

Fig. 3-31: Manipulation protection against shadow

### Evaluation field

A field is selected from the configuration evaluation fields for the evaluation instance. Its shape must correspond to the evaluation strategy (see [Chapter 3.8.2 Evaluation fields, Page 50](#)).

### Logical output

One of the logical outputs is selected for the evaluation instance. If several evaluation instances act on one logical output, specify how the results of the evaluation instances are linked (see [Chapter 3.8.3 Linking the evaluation instances to the logical output, Page 50](#)).

### Negation of the results

By negating the results, the field evaluation is conversely transmitted to the logical output. The output that is used is hence switched (for example) when the evaluation field is free, or when the contour has not been violated.

**Important** The "Negation of the results" function does not correspond to the setting option "active high/active low" (level) for the external, physical outputs (see [Chapter 3.8.3 Linking the evaluation instances to the logical output, Page 50](#)).

### 3.8.2 Evaluation fields

Up to 16 evaluation fields can be configured using field monitoring. There is almost no restriction to the configuration of the size and shape of these the 16 evaluation fields.

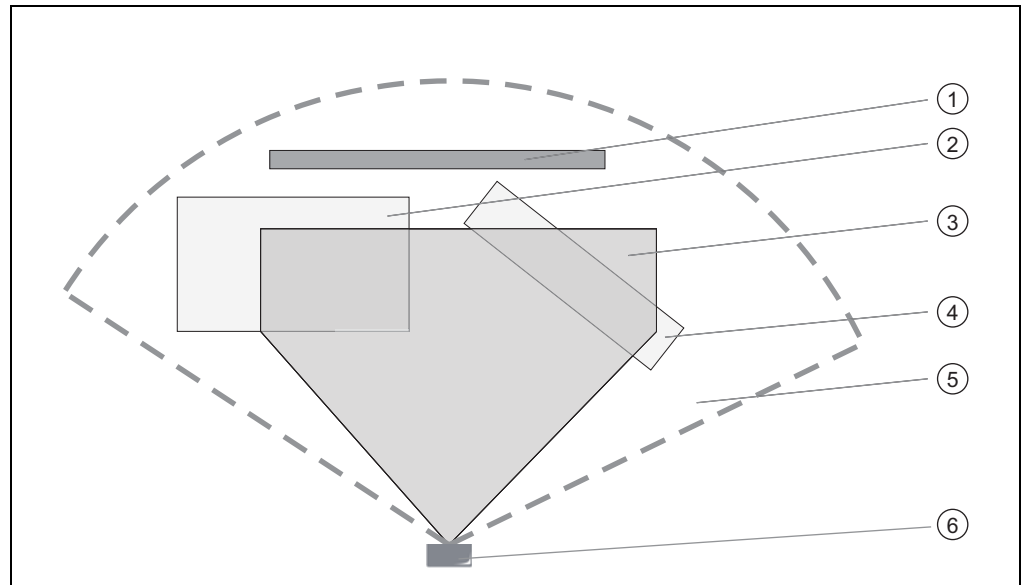

Fig. 3-32: Examples of evaluation field shapes

Caption:

- 1 Evaluation field for contour monitoring
- 2 Rectangular evaluation field at a distance from the LD-MRS
- 3 Polygonal evaluation field
- 4 Rotated evaluation field
- 5 LD-MRS scanning range
- 6 LD-MRS

The evaluation fields can be marked directly with the SOPAS-ET corresponding to the requirements of the application. Evaluation fields can have the following shapes and positions:

- Polygon
- Rectangle
- Extending up to the LD-MRS
- At a distance from the LD-MRS

When the range to be monitored changes, the LD-MRS can be reconfigured using software without additional installation.

### 3.8.3 Linking the evaluation instances to the logical output

If several evaluation instances act on one logical output, specify how the results of the evaluation instances are linked. The results can be AND-linked or OR-linked.

The external, physical outputs are configured by default as "active high".

#### Resetting a logical output

Logical outputs are reset immediately by default. However, a delay up to 10 seconds can be set (for example to activate a horn, or to send the output signal to a PLC).

Alternately, the output can be reset by an input. The output is only reset when the assigned input assumes the configured status.

### 3.9 Function of the 8-layer sensors

The LD-MRS features two sender elements and four receiver elements. The elements are mounted such that they each cover a particular viewing angle and thus measure different approach angles.

The rotating mirror that deflects the lasers is mounted at a slight angle to the axis of rotation. This design means that the front and back of the mirror each have a different field of vision, thus extending the vertical range covered.

The lower scan field is generated by the back of the mirror. The upper scan field is generated by the front of the mirror.

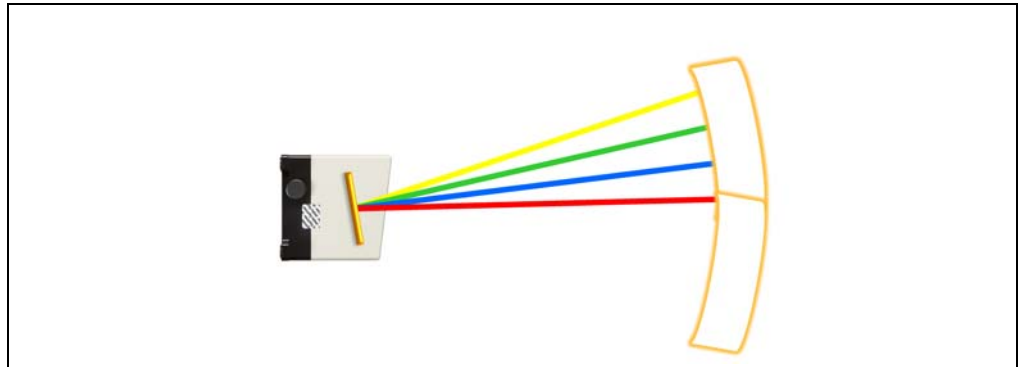

Fig. 3-33: Function of the 8-layer sensors – upper scan field

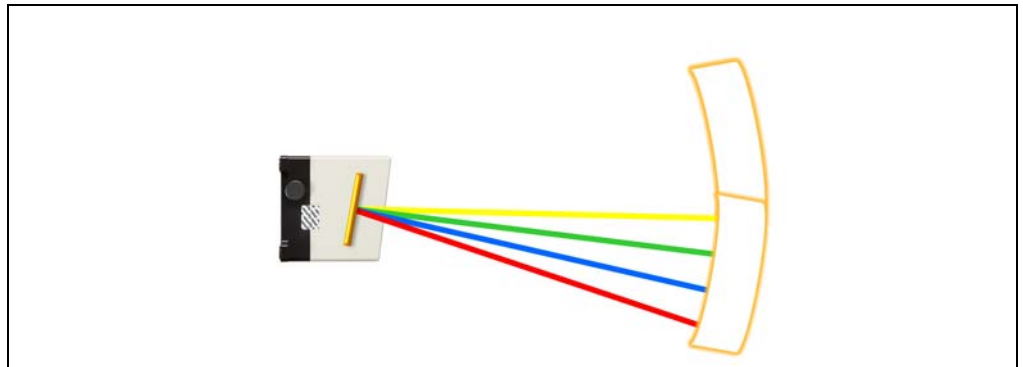

Fig. 3-34: Function of the 8-layer sensors – lower scan field

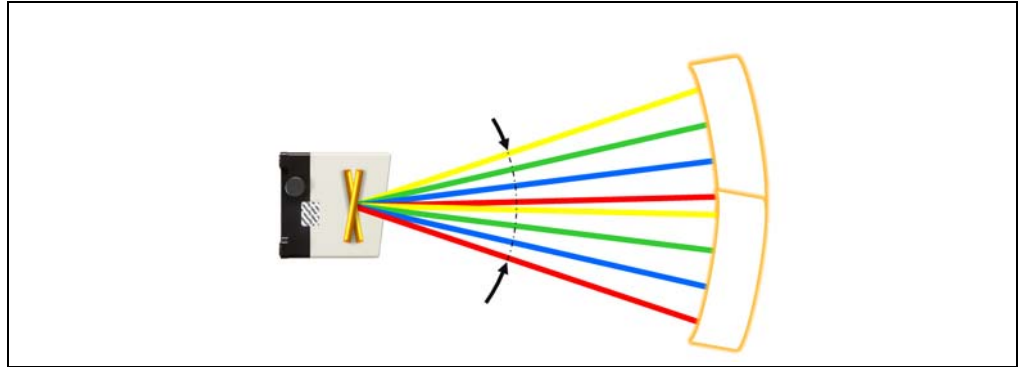

Fig. 3-35: Function of the 8 layer sensor – overlapping scan fields

The alignment of the mirror provides a continuous vertical field of vision. The upper and lower scan fields start to overlap at a scanning angle of  $-50^\circ$ .

### 3.10 Physical switching inputs and outputs

#### 3.10.1 External switching inputs (digital)

The LD-MRS does not have a direct, physical switching input.

A maximum of two external switch inputs can be implemented for the LD-MRS using a CAN module (optional accessory).

These inputs can turn specific evaluation instances on and off (see [Chapter 3.8.1 Evaluation instances, Page 48](#)). The external outputs of the LD-MRS can be reset by using inputs ([Chapter Resetting a logical output, Page 50](#)).

#### 3.10.2 External switching outputs (digital)

The LD-MRS does not have a direct, physical switching output.

A maximum of 10 external switching outputs can be implemented for the LD-MRS using a maximum of two optional CAN modules (together with the optional switching inputs).

If an output is switched by the field monitoring, the LD-MRS reports field violations or contour violations as the results (results). Use SOPAS-ET to specify which evaluation instance acts on which output.

#### 3.10.3 CAN module (optional accessory)

The aforementioned AND module is available with two types of protection:

- IP 20: type  $\mu$ CAN.8.dio-SNAP (Part No. 6038825), plastic housing for top hat rail installation with 16 terminals.

LD-MRS

Fig. 3-36:  $\mu$ CAN.8.dio-SNAP module

- IP 67: type  $\mu$ CAN.8.dio-BOX (Part No. 6041328), small metal housing with seven threaded holes for cable glands (4 x M16, 3 x M20) and 36 terminals. An additional set (Part No. 6043917) consisting of 5 cable glands/2 blind covers (in metal) is available.



Fig. 3-37:  $\mu$ CAN.8.dio-BOX module

The address range of 1 to 127 is available in the CAN bus. By default, the LD-MRS has the address 1. The transmission rate of 500 kBit/s is fixed by the LD-MRS and needs to be set for the two CAN modules.

When a cable is used to connect to the LD-MRS (Part No. 2050647 (2 m (6.56 ft))/Part No. 2050648 (8 m (26.2 ft)) in maximum configuration, both CAN modules are connected to the end of the bus via the 9-pin D-sub connector. The required terminals are created using the internal switches of each module. If only one module is connected to the LD-MRS, the 9-pin D-sub connector (Part No. 6042511) offers an integrated termination resistor for one end of the bus as an adapter.

### 3.11 Status indicators and controls

The LD-MRS does not have any status indicators like LEDs, and it does not have any controls like switches. The device is configured for measurement mode by means of commands in messages or using the "SICK LaserView Customer Edition" visualization tool via the Ethernet interface and is switched to measuring mode. Configuration for field monitoring is performed using the SOPAS-ET.

LD-MRS

**Notes:**

## 4 Mounting

This chapter describes the mounting steps for the LD-MRS.

### 4.1 Overview of the mounting steps

The following list gives an overview of the typical mounting steps:

- select a mounting location for the LD-MRS
- mount and adjust the LD-MRS

### 4.2 Preparations for mounting

In general, observe the following requirements for mounting:

- mounting location with free view of the scanning range of the LD-MRS, see [Chapter 9.2.4 Holder \(optional accessory\), Page 100](#).
- stable mounting support with sufficient bearing capacity and suitable dimensions for LD-MRS
- if needed behind a pane (glass or acrylic glass) which is transparent for infrared light (905 nm). For more detailed information about suitable material contact SICK AG.

The following accessories are required for mounting:

- 4 M6 screws of property class 8.8 to attach the LD-MRS at the mounting support. The length of the screws depends on the wall thickness of the support.
- Tools

#### 4.2.1 Prepare the components to be mounted

- Laser measurement sensor LD-MRS
- Optional: Mounting bracket for adjustable alignment of the LD-MRS
- In addition for field monitoring:
  - depending on the number of employed logical switching outputs and inputs, one or two optional CAN modules for installation in the system (box) or the switching cabinet on a top hat rail (snap)
  - When using only one CAN module, the connector (Part No. 6042511) with integrated termination resistance

#### 4.2.2 Mounting device

The LD-MRS is attached by means of the 4 holes located in the four projecting attachment lugs at the rear side of the device.

To make it easier to align the LD-MRS and protect from external influences, SICK AG offers the following optional accessories:

- Holder Part No. 1047429 (adjustable in 2 axes)
- Weather resistant cover Part No. 2058033



### 4.3 Mounting and adjustment of the device

After mounting the LD-MRS, adjust the matching angles and the distance to the reference plane.

#### 4.3.1 Mounting the LD-MRS

For mounting the LD-MRS safely at the mounting location, 4 M6 screws with washers and lock washers are required. The supply voltage of the LD-MRS must be switched off.

#### 4.3.2 Distance between LD-MRS and object/surface to be monitored

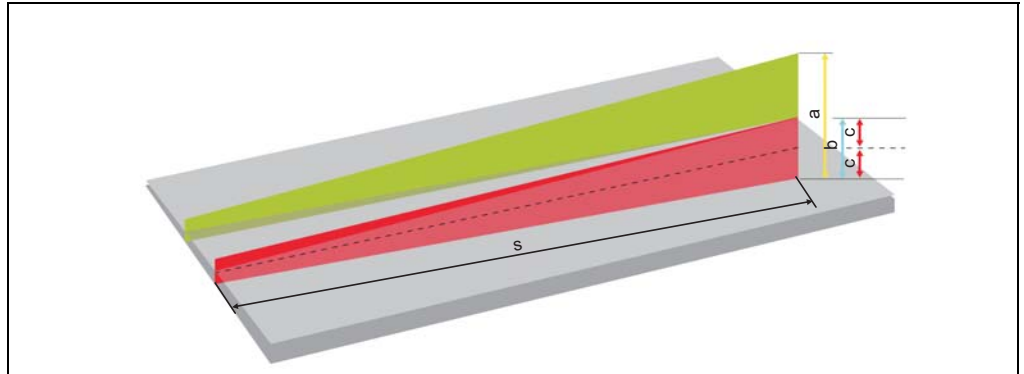

Fig. 4-1: Beam expansion

Caption:

- a vertical beam expansion for four layers
- b vertical beam expansion for two layers (one laser pulse)
- c vertical beam expansion for one layer
- s distance in mm

The reference plane for the required distance to the floor/wall is the sensor point of origin, see [Chapter 9.2.2 LD-MRS laser measurement sensor: Dimensions, Page 98](#).

The distance-dependant beam expansion can be calculated with this formula:

- vertical beam expansion for one layer = distance  $\times$  0.014
- horizontal beam expansion for one layer = distance  $\times$  0.0014

For some example values see [Tab. 3-6, Page 30](#), [Tab. 3-7](#) and [Tab. 3-8](#).

4.3.3 Mount the LD-MRS on the optional holder Part No. 1047429

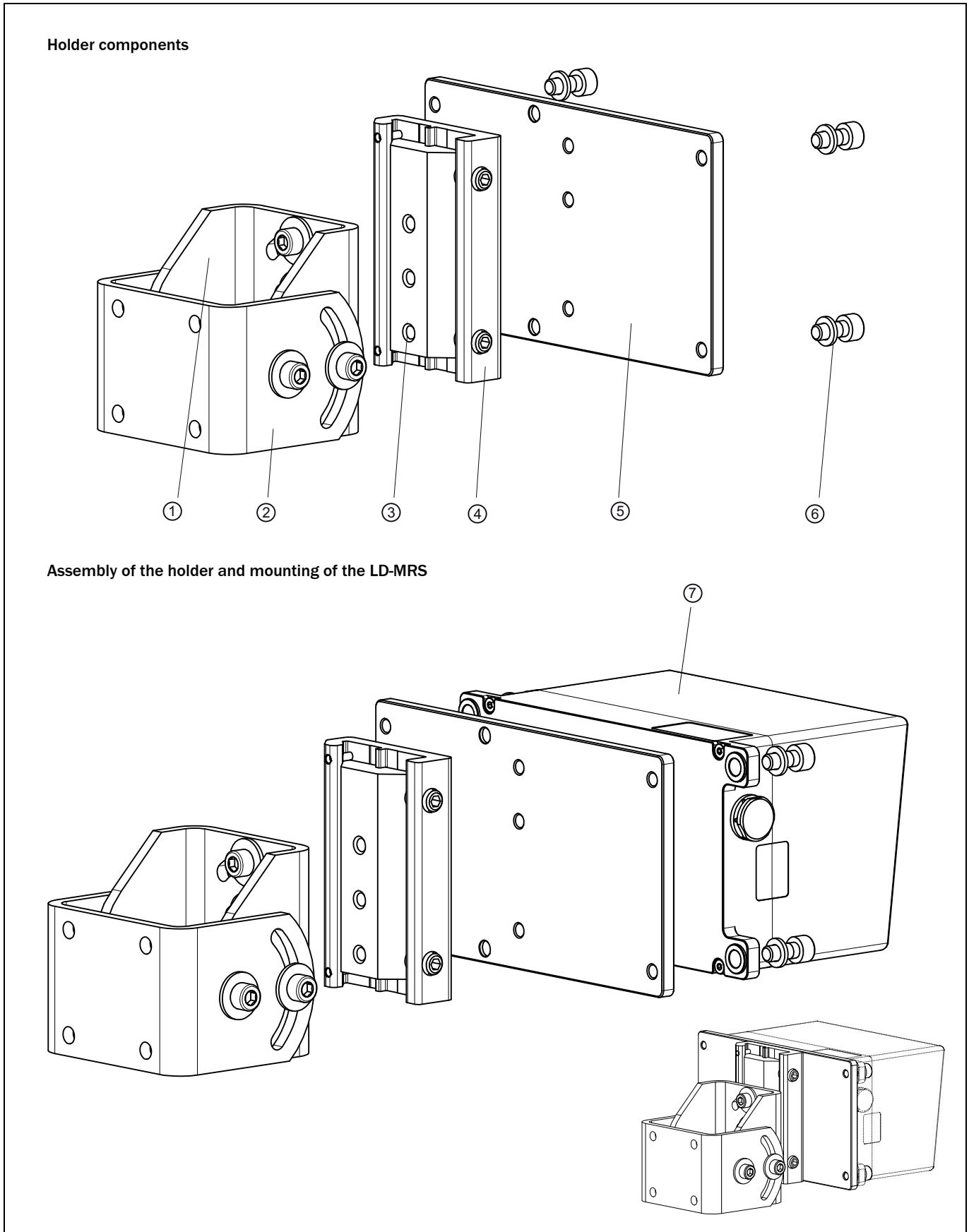

Fig. 4-2: Mount the LD-MRS on holder Part No. 1047429

## LD-MRS

Caption:

- 1 Bracket 1
- 2 Bracket 2
- 3 Quick release 1
- 4 Quick release 2
- 5 Mounting plate
- 6 M6 x 14 screws, self locking (4)
- 7 LD-MRS

1. Mount bracket 2 to quick release 1.
2. Mount quick release 2 on the mounting plate.
3. Mount bracket 1 to bracket 2.
4. Mount quick release 1 to quick release 2.
5. Mount LD-MRS to the mounting plate.

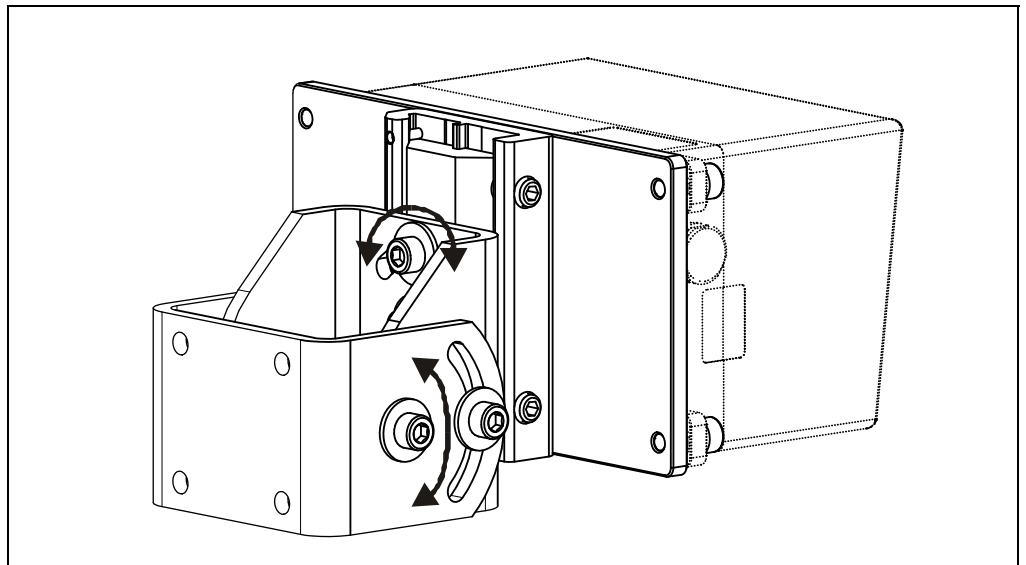

Fig. 4-3: Adjust the holder

By means of bracket 1 and 2, the LD-MRS can be aligned in two planes. The maximum adjustment angle in both planes is  $\pm 45^\circ$ .

Quick releases 1 and 2 enable the LD-MRS to be quickly exchanged without having to recalibrate a new device.

4.3.4 Mount the LD-MRS on the optional weather resistant cover Part No. 2058033

Components of the weather resistant cover and ways to install the fastening bracket

Version 1: Install the bracket by introducing the screws from the back

Version 2: Install the bracket by introducing the screws from the front

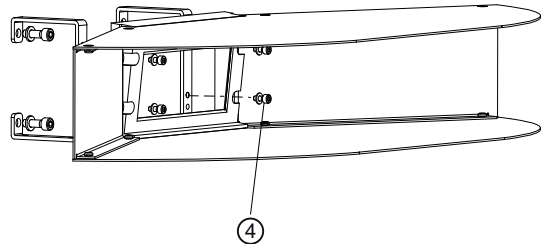
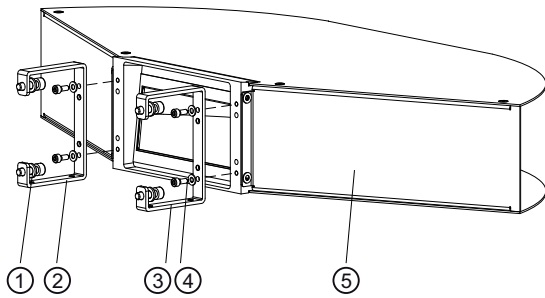

Install the weather resistant cover and insert the LD-MRS

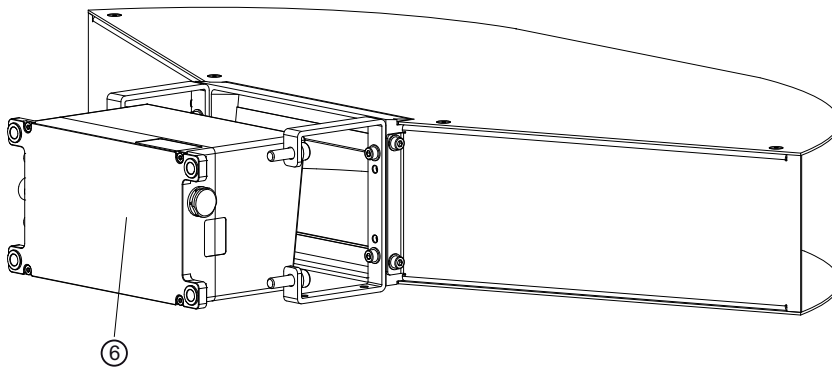

Install the holder No. 1047429 on the LD-MRS

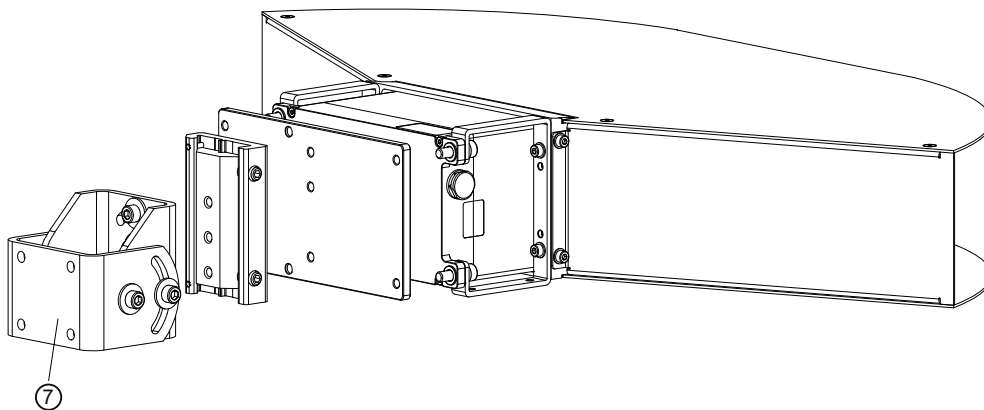

Fig. 4-4: Mount the LD-MRS on the weather resistant cover Part No. 2058033 and on the holder Part No. 1047429

## LD-MRS

Caption:

- 1 M6 x 20 screws, self locking (4)
- 2 Retention bracket 1
- 3 Retention bracket 2
- 4 M4 x 10 screws, self locking (4)
- 5 Body with frame
- 6 LD-MRS
- 7 Holder

**Recommendation** Only mount the LD-MRS on the weather resistant cover Part No. 2058033 when the holder Part No. 1047429, see [Fig. 4-2](#), is used.

**Explanation** Advantage of version 2: The weather protection cover can be removed for cleaning without having to unscrew the LD-MRS from the retention bracket.

1. Mount retention brackets 1 and 2 on the body with the frame; see versions 1 or 2 in [Fig. 4-4](#).
2. Shove the LD-MRS between retention bracket 1 and 2 to the body with the frame.
3. Mount the mounting plate of the holder on the LD-MRS.

#### 4.4 Mount the optional CAN module

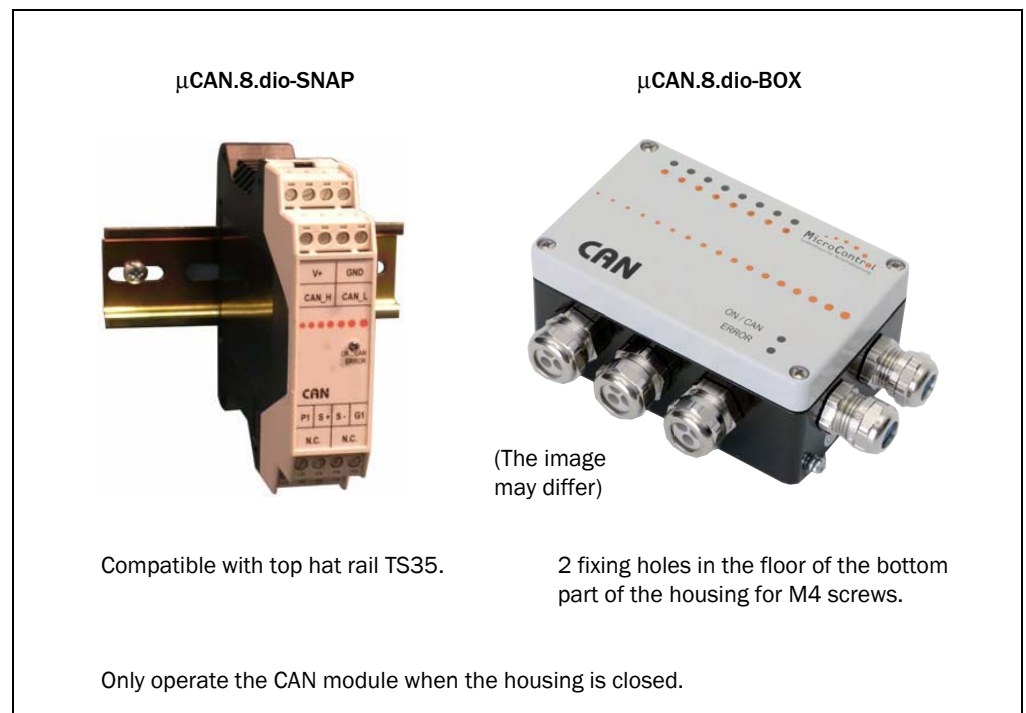

Fig. 4-5: Mount the optional CAN module

## 4.5 Dismounting the device

1. Switch off the supply voltage of the LD-MRS.
2. Disconnect the connection cables of plug and sockets of the LD-MRS.
3. Unscrew and remove the attachment screws of the LD-MRS, and remove the device.

### 4.5.1 Storage

## NOTICE

### Property damage!

Improper storage can cause damages at the LD-MRS.

Condensing humidity can damage the optical components.

- Prepare the device for storage.

---

For the permitted storage temperature and humidity, see [Chapter 9 Technical specifications, Page 94](#).

Observe the following when storing the LD-MRS:

- Dry the LD-MRS carefully
- Do not store the device in airtight containers so that any residual humidity can escape
- Use original packaging whenever possible

LD-MRS

**Notes:**

## 5 Electrical installation

### 5.1 Overview of the installation steps

**Important** Only trained personnel may perform the electrical installation.

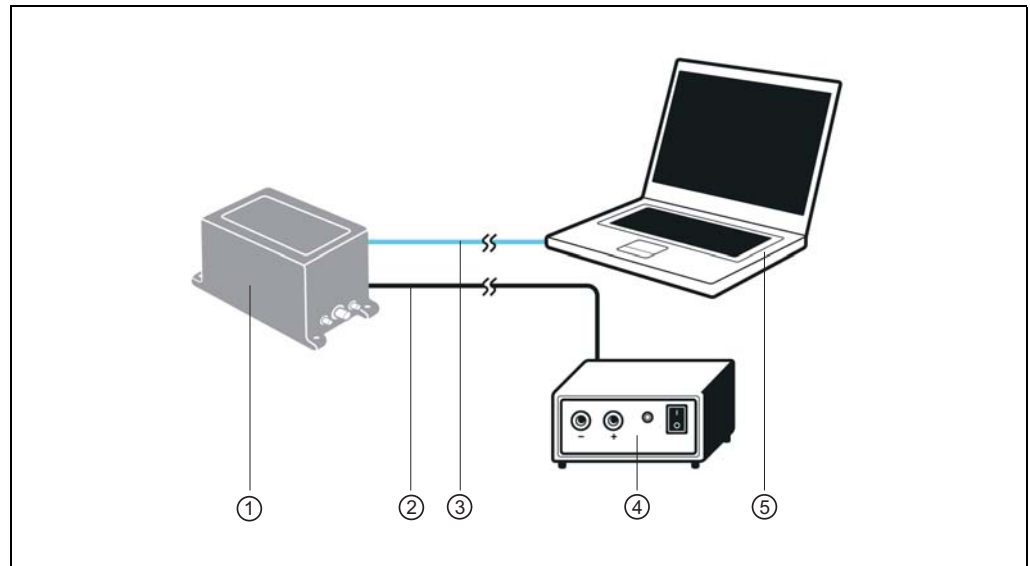

Fig. 5-1: Measuring mode: Electrical installation of the LD-MRS

Caption:

- 1 LD-MRS
- 2 Power supply line
- 3 Ethernet data cable
- 4 Power supply
- 5 Desktop/laptop (temporary, configuration) or host computer (measurement processing)

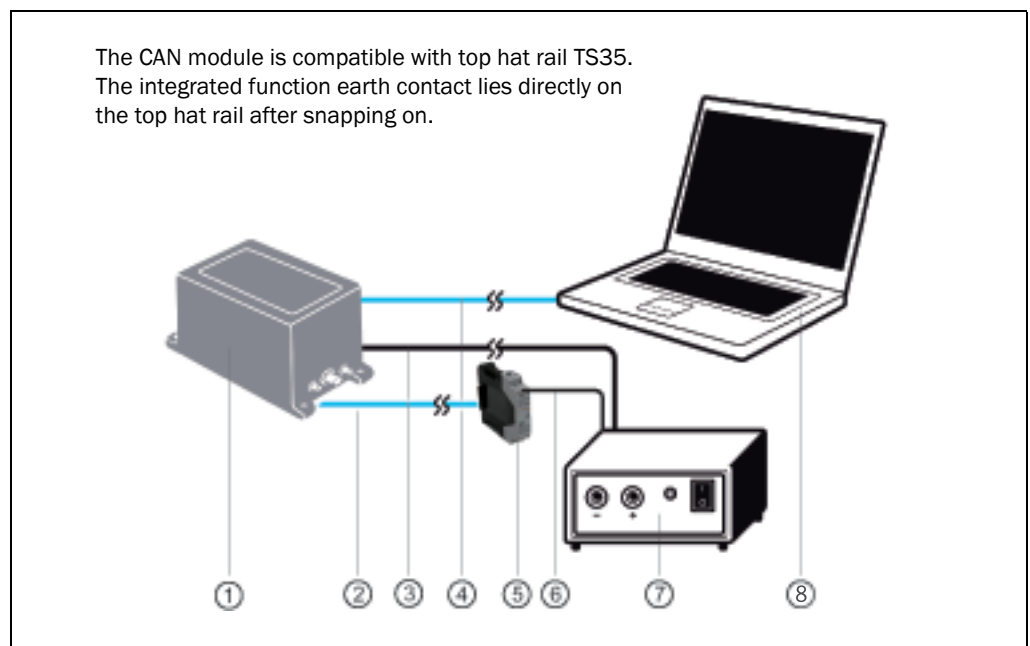

Fig. 5-2: Field monitoring: Electrical installation of the LD-MRS and the CAN module



Caption:

- 1 LD-MRS
- 2 Connection of the CAN module to the LD-MRS
- 3 Power supply line
- 4 Ethernet data cable
- 5 CAN module(s) with digital I/O ports
- 6 Power supply line for the CAN module
- 7 Power supply
- 8 Desktop/laptop (temporary, configuration)

The following list provides an overview of the required installation steps:

- Connect the LD-MRS to the supply voltage
- Connect the PC temporarily (configuration)
- Measuring mode: Turn on the data interface for operation (depending on the use)  
- or -
- Field monitoring: Wiring of the external switching inputs and outputs  
Connect the module to the power supply

After finishing the electrical installation, commission and configure the LD-MRS, see [Chapter 6 Commissioning and configuration, Page 81](#).

## 5.2 Planning the electrical installation

In general, observe the following requirements for electrical installation:

- A supply voltage of 9 to 27 V DC, typical 12/24 V DC (function extra-low voltage in accordance with IEC 60364-4-41).  
The voltage supply must provide at least 36 W power output. The device can be connected to a supply by solar energy.
- Electrical isolation of RS232 and sync:
- If cables are long or the sensor and evaluation computer are far apart from one another, potential differences can occur. To prevent damage, please use an RS232 isolator on the sync inputs and outputs for electrical isolation.
- Measuring mode:  
Host computer (such as a vehicle computer) with an Ethernet interface for processing the measurements from the LD-MRS
- Field monitoring:  
External control required for
  - processing the output switching signals from the LD-MRS
  - optional arming of specific evaluation instances using the switching inputs of the LD-MRS
- PC/laptop with Ethernet interface for temporary connection for configuration/visualization of the measured data
- Connection lines: see the order information in the product information "Product family of the laser measurement sensor LD-MRS" or [Tab. 5-4, Page 67](#).

### NOTICE

**Damage hazard!**

- ⚠ The sensor must not be operated without supply voltage ground or a potential difference between data ground and supply voltage ground.

### 5.3 Electrical connections and cables

The connections of the LD-MRS consist of three round plug-in connections. These connections lead to the following interfaces:

- Ethernet data interface
- Data interface RS-232 (auxiliary data interface)
- Data interface CAN
- synchronization interface
- Power supply

#### 5.3.1 Pin assignment of the connections

##### Connection "Ethernet"



Pin	Signal	Function
1	RX-	Receive-
2	TX+	Transmit+
3	TX-	Transmit-
4	RX+	Receive+

Tab. 5-1: Pin assignment of the 4-pin socket (round plug-in connection) "Ethernet"

##### Connection "Data interfaces/Synchronization"

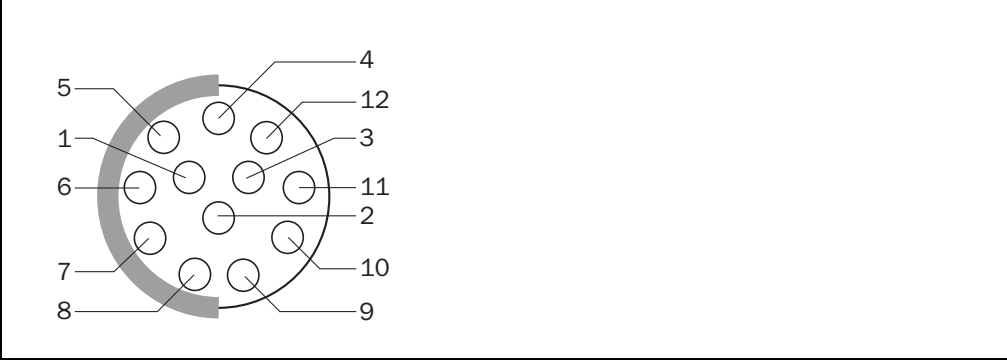

Pin	Signal	Function
1	TxD	RS-232, Transmit
2	Sync-out	Sensor Sync.
3	Sync-in	Sensor Sync.
4	Data GND (Sync-in)	Data Ground
5	Data GND (Sync-out)	Data Ground
6	Data GND (TxD, RS-232)	Data Ground
7	RxD	RS-232, Receive

Tab. 5-2: Pin assignment of the 12-pin plug "data interfaces/synchronization" (round plug-in connection)

8	Data GND (RxD, RS-232)	Data Ground
9	CAN_L1	CAN bus (connection 1)
10	CAN_H1	CAN bus (connection 1)
11	CAN_L2	CAN bus (connection 2)
12	CAN_H2	CAN bus (connection 2)

Tab. 5-2: Pin assignment of the 12-pin plug "data interfaces/synchronization" (round plug-in connection)

**Connection "Power"**

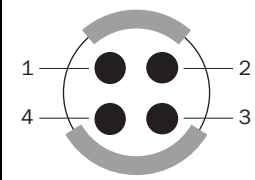
		
Pin	Signal	Function
1	Power GND	Supply voltage Ground
2	V <sub>s</sub>	Supply voltage
3	V <sub>s</sub>	Supply voltage
4	Power GND	Supply voltage Ground

Tab. 5-3: Pin assignment of the 4-pin plug "Power" (round plug-in connection)

**5.3.2 Assembled cables (overview)**

Cable Part No.	Type	Ambient operating temperature	Length	Connection LD-MRS to
2049823	Supply line, shielded, 4-pin round socket and open end (2 multiple spring wire plug)	-30 to +80 °C (-22 to +176 °F)	2 m (6.56 ft)	Power supply
2049824			8 m (26.2 ft)	
2049825			20 m (65.6 ft)	
2067524	Supply line, angled, shielded, 4-pin round socket and open end (2 multiple spring wire plug)		8 m (26.2 ft)	
2049826	Ethernet data cable (crossover), shielded, 4-pin plug (round plug-in connection) and 8-pin RJ-45 plug	-40 to +80 °C (-40 to +176 °C)	2 m (6.56 ft)	Ethernet (PC directly or via network)
2049827			8 m (26.2 ft)	
2049828			20 m (65.6 ft)	
2067517	Ethernet data cable (crossover), angled, shielded, 4-pin plug (round plug-in connection) and 8-pin RJ-45 plug		8 m (26.2 ft)	
2049829	Connecting cable for synchronization, shielded, 12-pin plug (round plug-in connection) and 9-pin D-Sub plug	-10 to +80 °C (+14 to +176 °F)	2 m (6.56 ft)	Second LD-MRS or other device
2049830			8 m (26.2 ft)	
2049832	Extension cable for connection "data interface/synchronisation", shielded, 12-pin plug and 12-pin socket (both round plug connectors).	-10 to +80 °C (+14 to +176 °F)	8 m (26.2 ft)	
2049831	Cable splitter 1:3, shielded, 12-pin plug on 9-pin D-Sub plug (synchronisation), 9-pin D-Sub socket (RS-232) and 9-pin D-Sub socket (CAN, reserved)	-10 to +80 °C (+14 to +176 °F)	2 m (6.56 ft)	PC (RS-232) second LD-MRS
2054647	CAN data line, shielded, 12-pin connector and 9-pin D-Sub socket (2 CAN)	-10 to +80 °C (+14 to +176 °F)	2 m (6.56 ft)	CAN module(s) (accessory)
2054648			8 m (26.2 ft)	
6042511	CAN terminating resistor (D-Sub plug-in connector)		-	-

Tab. 5-4: Assembled cables for connecting the LD-MRS

Pin / wire colour assignment of the cables see [Chapter 5.5 Pin assignments and wire colors of the assembled cables, Page 78](#).

## **NOTICE**

### **Damage hazard!**

- When laying the cables, the bending radius of the cables must be at least 70 mm (2.76 in) in. Else the cables could be damaged.

### 5.4 Perform electrical installation

- Electrical connection may only be established or disconnected when not under voltage.
- Specify and implement the wire diameter and the correct fusing according to valid standards.
- For data cables only use shielded cables (twisted pair).
- In order to prevent noise, do not lay data cables parallel to power supply or motor cables, e. g. in cable ducts.
- Lay all cables such that there is no risk of tripping and all cables are protected against damage.
- Do not switch on the supply voltage for the LD-MRS before all connection works are finished and the wiring has been checked thoroughly
- In applications with high solar radiation, please lay the cables in protective tubes.

#### 5.4.1 Connect the supply voltage

##### Supply voltage requirements

The LD-MRS requires for operation a supply voltage of 9 to 27 V DC (function extra-low voltage in accordance with IEC 60364-4-41). The function extra-low voltage can be generated by a power supply with a safety transformer in accordance with IEC 742.

**Important** The output circuit of the power supply must be safely electrically isolated from the input circuit, this feature is normally provided by a safety transformer in accordance with IEC 742.

The LD-MRS consumes the following power:

Process	Power consumption
Switch-on	typically 36 W (1.5 A at 24 V DC)
permanent operation	typically 8 W (0.34 A at 24 V DC)
permanent operation	max. 10 W (0.4 A at 24 V DC)

Tab. 5-5: Power consumption of the LD-MRS

The optional CAN module consumes approximately 1.5 W at DC 8 to 50 V without a load.

**Important** In order to ensure protection against short circuit / overload of the supply cable, dimension and fuse the wire cross-sections accordingly. The valid standards must be observed.

- Make sure that the voltage supply to which the LD-MRS will be connected, is switched off.
1. Connect the supply cable, e. g. Part no. 2049823 (2 m (6.56 ft)), to the LD-MRS, see [Fig. 5-3, page 70](#).
  2. Connect the supply cable voltage-free to the voltage supply.  
In order to bridge distances greater than 20 m (65.6 ft) (cable no. 2049825), use an extension cable at the consumer side between the supply cable and the voltage supply.

**Important** ➤ If you remove the bunch pin plugs of the supply cable and connect the cores directly to the terminal block, make sure to connect the shielding of the cable also at a suitable ground point.

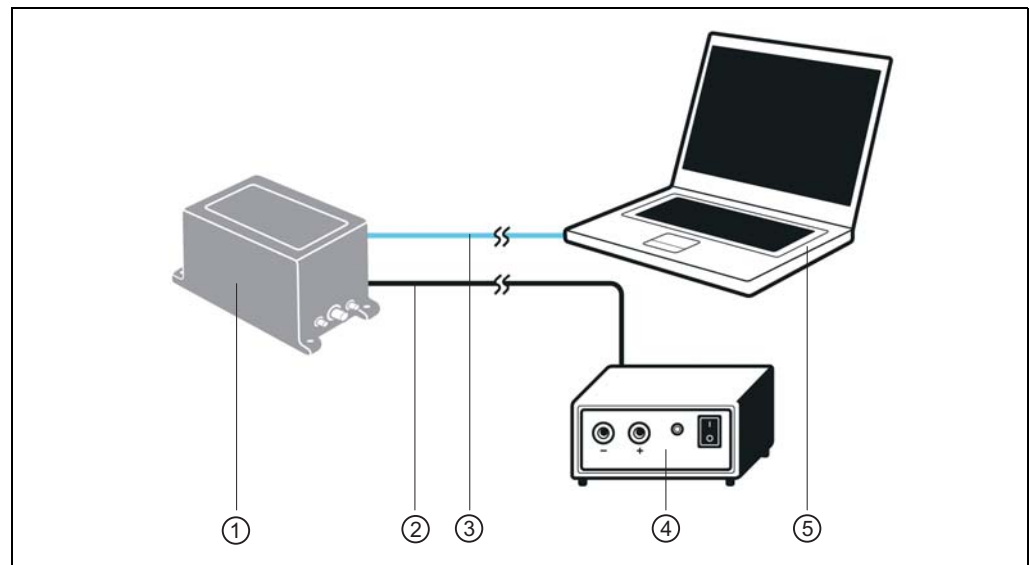

Fig. 5-3: Connection of the voltage supply and wiring of the Ethernet interface

Caption:

- 1 LD-MRS
- 2 Power supply line
- 3 Ethernet data cable
- 4 Power supply
- 5 Desktop/laptop

**Important** For the next steps of the installation, the supply voltage of the LD-MRS **remains switched off!**

#### 5.4.2 Connect the optional CAN modules (external I/O ports)

CAN modules (optional accessory)

### NOTICE

**Potential radio interference when using the optional CAN modules in residential areas.**

- Only use the laser measurement sensor LD-MRS together with the CAN modules in an industrial setting.

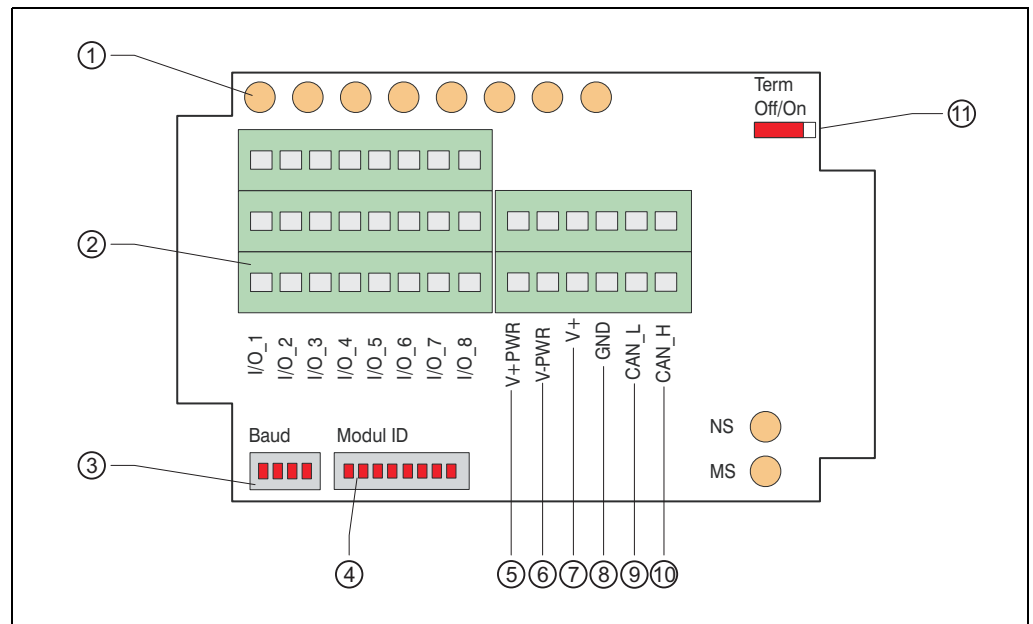

Fig. 5-4: Design of the CAN module  $\mu$ CAN.8.dio-BOX

Caption:

- 1 LED
- 2 Terminal strip of the digital switching inputs/outputs
- 3 DIP switch for the transmission rate
- 4 DIP switch for the address
- 5 Terminal  $V_{+PWR}$
- 6 Terminal  $V_{-PWR}$
- 7 Terminal for the power supply  $V_{+}$
- 8 Terminal for the power supply GND
- 9 Terminal for CAN bus CAN\_L
- 10 Terminal for CAN bus CAN\_H
- 11 Termination switch

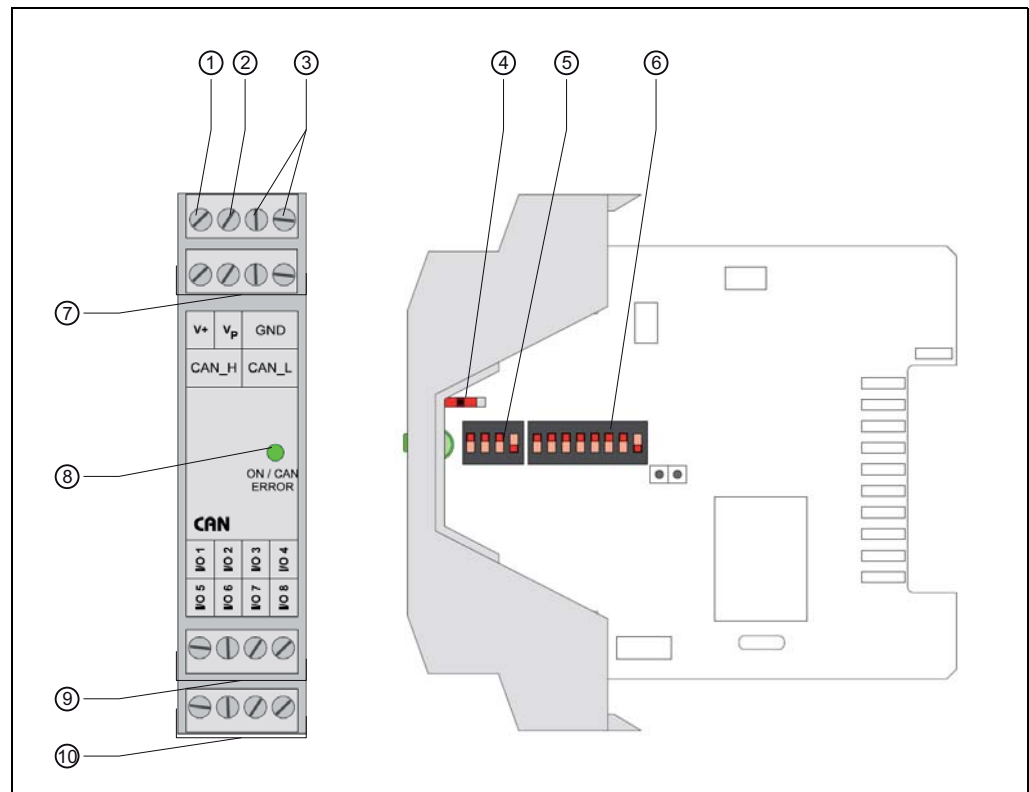

Fig. 5-5: Design of the CAN module  $\mu$ CAN.8.dio-SNAP

#### Caption:

- 1 Terminal for the power supply V+
- 2 Terminal V<sub>p</sub>
- 3 Terminal for the power supply GND
- 4 Switch for termination
- 5 DIP switch for the transmission rate
- 6 DIP switch for the address
- 7 Terminal for the CAN bus CAN\_H and CAN bus CAN\_L
- 8 LED
- 9 Terminal strip of digital switching inputs/outputs 1 to 4
- 10 Terminal strip of digital switching inputs/outputs 5 to 8

#### CAN bus

Since the fixed transmission rate of the LD-MRS is 500 kBit/s, the maximum bus line length is 100 m (328 ft).

ISO 11898 recommends the following wire cross section: 0.25 mm<sup>2</sup> (24 AWG) (for 0 to 40 m (0 to 131.2 ft)) and 0.34 mm<sup>2</sup> (22 AWG) (for 40 to 100 m (131.2 to 328 ft)).

The bus must be connected to each end of the cable with a 120 Ohm resistor (terminated). It is recommendable to use a shielded (braided), twisted two-wire cable with a surge impedance of 120 Ohm.



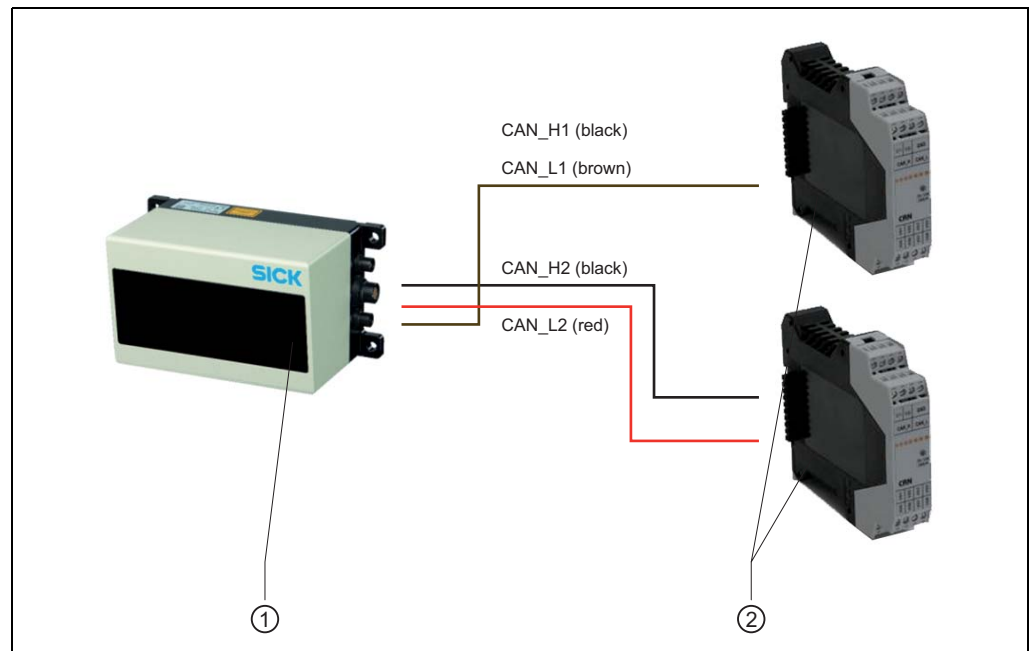

Fig. 5-6: Connect two CAN modules to the CAN interface of the LD-MRS

Caption:

1 LD-MRS

2 CAN module

When a cable (Part No. 2050647 (2 m (6.56 ft))/ 2050648 (8 m (26.2 ft))) is used to connect to the LD-MRS in maximum configuration, both CAN modules are connected to the end of the bus via the 9-pin D-sub connector, see [Fig. 5-6](#)

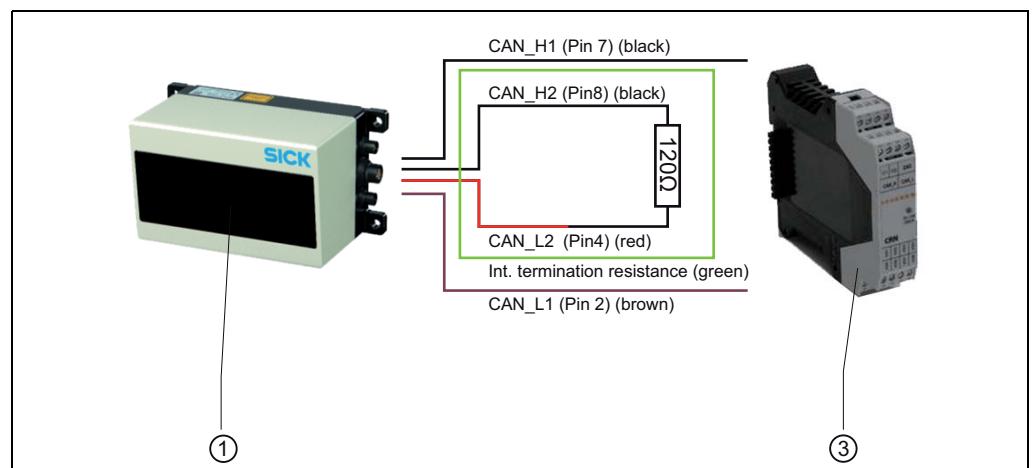

Fig. 5-7: Connect one CAN module to the CAN interface of the LD-MRS

Caption:

1 LD-MRS

2 CAN module

If only one CAN module is connected to the LD-MRS, the CAN terminating resistance (D-Sub connector) Part no. 6042511 is integrated in the termination resistance for the other end of the bus, see [Fig. 5-7, page 73](#).

### Termination

The required termination is provided by a CAN module via the internal termination switch; see [Fig. 5-4, page 71](#) and [Fig. 5-5, page 72](#).

Termination is active when the termination switch is in the ON position.

### Digital switching inputs

The digital switching inputs of the CAN modules are connected to the positive supply voltage  $V_{+PWR}$  (high side).

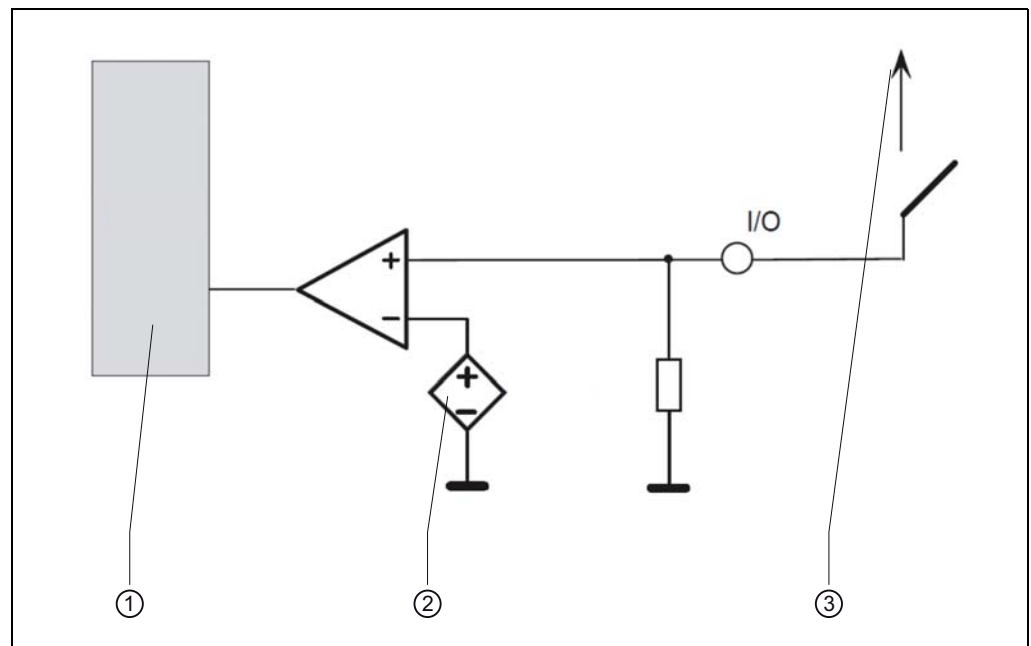

Fig. 5-8: Input switched against  $V_{+PWR}$

Caption:

1 logic

2  $V_{ref}$

3  $V_{+PWR}$

**Digital switching outputs**

The digital switching output of the CAN modules are connected to the positive supply voltage  $V_{+PWR}$  (high side driver).

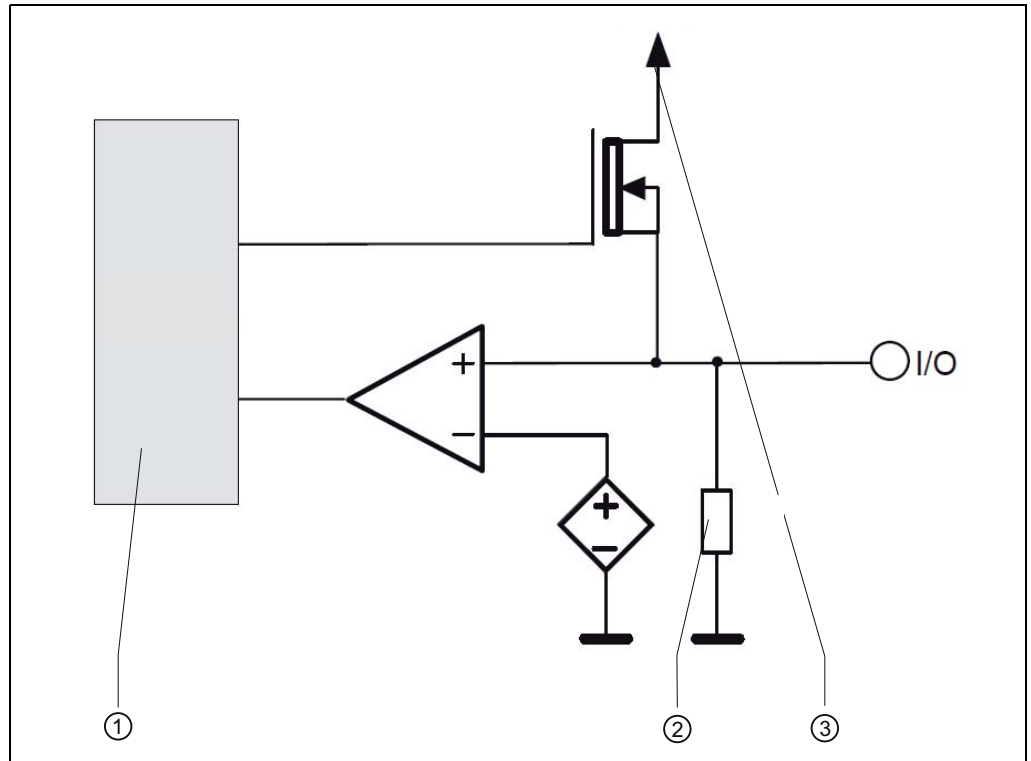

Fig. 5-9: A circuit diagram of digital I/O terminal (high side driver)

Caption:

- 1 logic
- 2 impedance  $R_{in}$
- 3  $V_{+PWR}$

**5.4.3 Configuring the CAN module**

**Setting the CAN address**

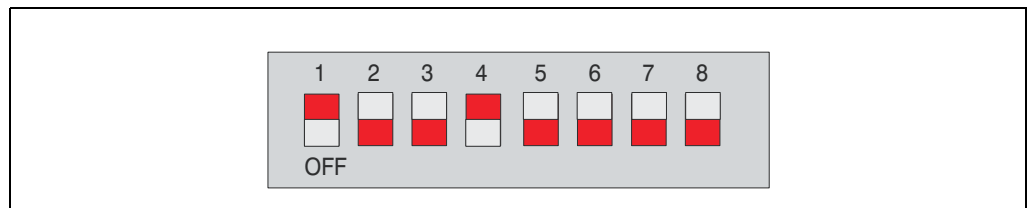

Fig. 5-10: DIP switch for address (example: address 9)

For addressing in the CAN bus, the address range 1 to 127 is available. By default, the address of the LD-MRS is 1. Each address assigned to a device may only occur once (such as 10, 11, 12).

**Important** Switch 8 must always be in the 0 position (OFF).

The switches may never all be in the 0 position (OFF) at the same time. In this configuration, the CAN module will not start.

### Setting the transmission rate

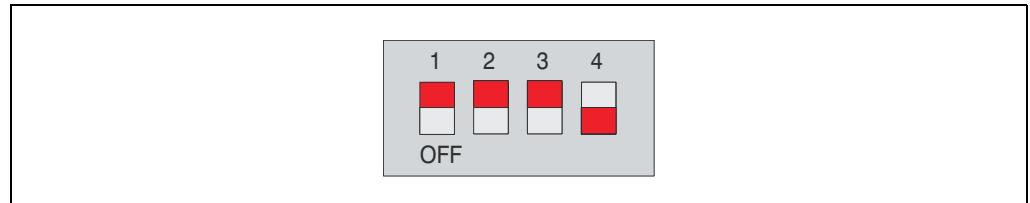

Fig. 5-11: DIP switch for transmission rate (example: 500 kBit/s)

- Set a transmission rate of 500 kBit/s for the CAN modules.

#### 5.4.4 Connect the CAN to the supply voltage

- Use the supply cable to connect the supply voltage (8 to 50 V DC) to V+ and GND. The optional CAN module consumes approximately 1.5 W at 8 to 50 V DC without a load.

### 5.4.5 Connect PC/laptop

#### Ethernet interface

To configure using the visualization tool SICK LaserView Customer Edition (measuring mode) or the configuration software program SOPAS-ET (field monitoring), use a crossover cable such as Part No. 2049826 to connect the LD-MRS to the ethernet port of the computer.

#### RS-232 interface

In order to be able to access the RS-232 interface as auxiliary data interface, connect the LD-MRS via a data cable, e. g. Part no. 2049831, to the COM port of the PC, see [Fig. 5-12](#).

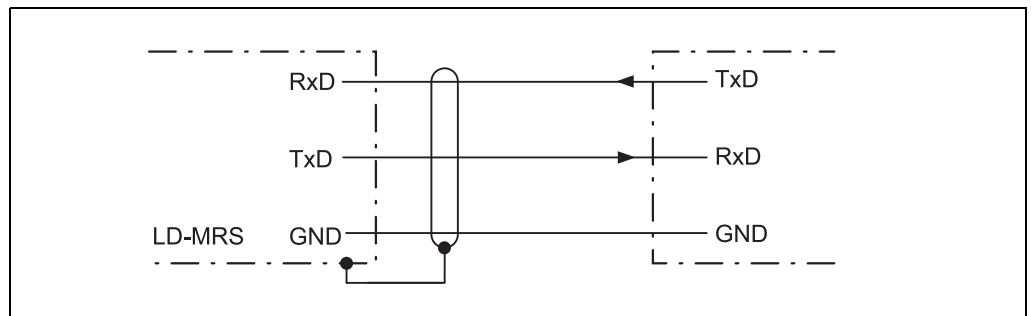

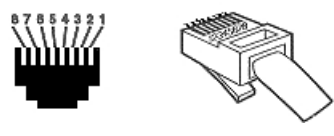

Fig. 5-12: Wiring of the RS-232 interface

### 5.5 Pin assignments and wire colors of the assembled cables

#### 5.5.1 Pin assignment of the assembled cables

Cable Part no. 2049826, 2049827, 2067517, 2049828 (Ethernet data cable, crossover)

<b>4-pin plug (round plug-in connection)</b>  View from the front      View from the soldering side		<b>8-pin RJ-45 plug</b>  View from the front
<b>Pin*)</b>	<b>Signal</b>	<b>Pin</b>
1	RX-	2
2	TX+	3
3	TX-	6
4	RX+	1
		4 to 8 not assigned
*) Twisted wire pair: RX- (1) with RX+ (4); TX- (3) with TX+ (2)		

Tab. 5-6: Pin assignment of the Ethernet data cable

Cable Part no. 2049829, 2049830, 2067524 (connecting cable "Synchronization")

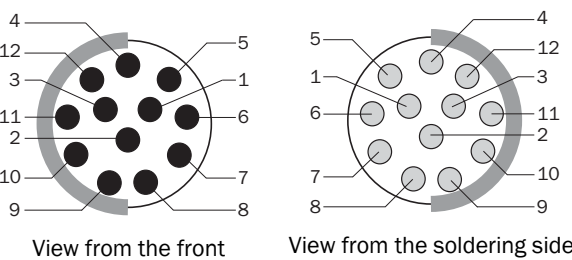
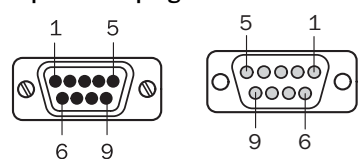
<b>12-pin plug (round plug-in connection)</b>  View from the front      View from the soldering side		<b>9-pin D-Sub plug</b>  View from the front      View from the soldering side
<b>Pin*)</b>	<b>Signal*)</b>	<b>Pin</b>
1	not assigned	-
2	Sync-out	6
3	Sync-in	9
4	Data GND	5
5	Data GND	8
6 to 12	not assigned	-
*) Twisted wire pair: Sync-in (3) with Data GND (4); Sync-out (2) with Data GND (5)		

Tab. 5-7: Pin assignment of the connecting cable "Synchronization"

Cable Part no. 2049831 (cable splitter 1:3)

<p><b>12-pin plug (round plug-in connection)</b></p> <p>View from the</p> <p>View from the soldering side</p>		<p><b>9-pin. D-Sub socket "RS-232 D-SUB"</b></p> <p>View from the front</p> <p>View from the soldering side</p>	<p><b>9-pin. D-Sub plug "SYNC D-SUB"</b></p> <p>View from the front</p> <p>View from the soldering side</p>	<p><b>9-pin D-Sub socket "CAN D-SUB"</b></p> <p>View from the front</p> <p>View from the soldering side</p>
<b>Pin*)</b>	<b>Signal</b>	<b>Pin</b>	<b>Pin</b>	<b>Pin</b>
1	TxD	2		
2	Sync-out		6	
3	Sync-in		9	
4	Data GND		5	
5	Data GND		8	
6	Data GND	5		
7	RxD	3		
8	Data GND	5		
9	CAN_L1			2
10	CAN_H1			7
11	CAN_L2			4
12	CAN_H2			8
<p>*) Twisted wire pair:                  Sync-in (3) with Data GND (4); Sync-out (2) with Data GND (5); TxD (1) with Data GND (6); RxD (7) with Data GND (8); CAN_L1 (9) with CAN_H1 (10); CAN_L2 (11) with CAN_H2 (12)</p>				

Tab. 5-8: Pin assignment of the cable splitter 1:3

**Cable Part no. 2054647, 2054648 ("CAN" connecting cable)**

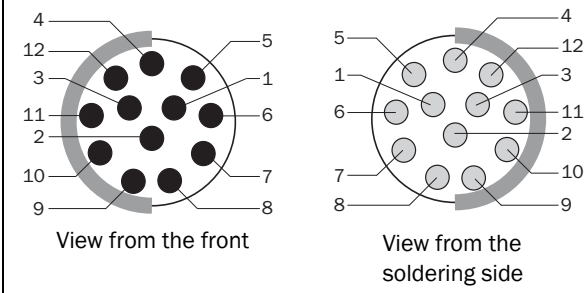
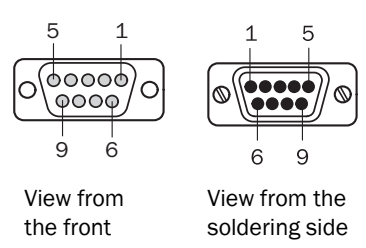
<p><b>12-pin plug (round plug-in connection)</b></p>  <p>View from the front      View from the soldering side</p>		<p><b>9-pin D-Sub socket</b></p>  <p>View from the front      View from the soldering side</p>	
<b>Pin*)</b>	<b>Signal</b>	<b>Pin</b>	
1 .. 8	not assigned	-	
9	CAN_L1	2	
10	CAN_H1	7	
11	CAN_L2	4	
12	CAN_H2	8	
*) Twisted wire pair: CAN_L1 (9) with CAN_H1 (10); CAN_L2 (11) with CAN_H2 (12)			

Tab. 5-9: Pin assignment of the CAN connecting cable

**5.5.2 Wire colour assignment of the assembled cables**

**Cable no. 2049823, 2049824, 2049825, 2067524 (supply cable)**

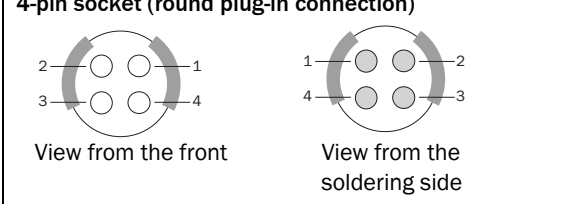
<p><b>4-pin socket (round plug-in connection)</b></p>  <p>View from the front      View from the soldering side</p>		<p><b>Open end with 2 bunch pin plugs</b></p>
<b>Pin</b>	<b>Signal</b>	
1	Power GND	black / white
2	V <sub>s</sub>	red / yellow
3	V <sub>s</sub>	red / green
4	Power GND	black / brown

Tab. 5-10: Wire colour assignment of the supply cable



## 6 Commissioning and configuration



### WARNING

**Do not start up without testing by a qualified technician!**

Before a system equipped with the LD-MRS is started up for the first time, it needs to be checked and released by a technician.

- Follow the instructions in [Chapter 2 For your safety, Page 9](#).

Start up and configuration of the LD-MRS is independent of the intended use with the following tools:

- SICK LaserView Customer Edition visualization tool for measuring mode.



The installation and use of SICK LaserView Customer Edition as well as the configuration of the LD-MRS are described in the operating instructions for the SICK LaserView Customer Edition visualization tool (Part No. 8013787, English version).

This document is also on the CD, "Manuals & Software LD-MRS".

- SOPAS-ET configuration program for field monitoring.

The installation and use of the SOPAS-ET are described in this section as well as the device-related online help in SOPAS-ET.

In normal mode, the LD-MRS is fully-automatic and does not require any operator intervention.

### 6.1 Overview for the startup steps for field monitoring

- Install the SOPAS-ET configuration program on the computer
- Connect PC to LD-MRS
- Take the LD-MRS into operation with the factory defaults
- To optimize the LD-MRS functionality, adjust the LD-MRS and adapt the configuration of the LD-MRS
- Use SOPAS-ET to create an application-specific set of parameters for field monitoring, and save them permanently in LD-MRS and on the computer
- Test LD-MRS for correct functionality

### 6.2 SOPAS-ET configuration program

SOPAS-ET is used for interactive configuration. With this configuration program, the parameters can be set and tested for the evaluation behavior and output characteristics of the LD-MRS for field monitoring is needed. The configuration data can also be saved and archived as a parameter set (project file) on the computer.

You can find help for using the program interface and individual options in SOPAS-ET:

- HELP menu, HELP F1: detailed online help on the program interface and individual options
- HELP window (bottom left in the user interface): Context-sensitive help for the most recently appeared dialog
- ToolTips: place the mouse pointer over an entry field. A small reference text (tool tip) appears with information on valid entries

The primary functions are:

- Select the menu language (German/English)

- Establish communication with the LD-MRS
- Password-protected configuration with different operating levels
- Diagnosis of the LD-MRS

### 6.2.1 System prerequisites for the SOPAS-ET

- Standard Intel Pentium computer or compatible, at least a Pentium III, 500 MHz
- Minimum of 512 MB RAM, 1024 MB RAM recommended
- Data interface RS-232, Ethernet or CAN
- Operating system: MS Windows 2000, XP, VISTA or Windows 7
- Monitor with at least 256 colors, recommended: 65,536 colors (16 Bit High Color)
- Minimum screen resolution: 800 × 600
- Hard disk: minimum of 300 MB free memory
- CD drive

### 6.2.2 Installation of SOPAS-ET

1. Start the computer and insert the installation CD
2. If the installation does not start automatically, call up "setup.exe" on the CD.
3. To complete the installation, follow the operation instructions.

### 6.2.3 Default setting of SOPAS-ET

Parameter	Value
Language of the user interface	English (the program needs to be re-started after a change)
Units of length	Metric
User group (operating level)	Maintenance staff
Download the parameters for the LD-MRS	Immediately when there is a change, temporary in the RAM of the LD-MRS
Upload the parameters of a LD-MRS	Automatic after going online
Window partitions	3 (Project tree, help, work area)
Serial communication	COM1: 9,600 Bd/19,200 Bd, 8 data bits, no parity, 1 stop bit

Tab. 6-1: Default setting of SOPAS-ET

## 6.3 Establish communication with the LD-MRS

**Important** To communicate via TCP-IP, the TCP-IP protocol must be active on the computer.

When connecting a computer to the host, maintain the following sequence:

1. Turn on the computer.
2. Connect the computer to the LD-MRS using a data cable.
3. Switch on the supply voltage of the LD-MRS.  
The LD-MRS runs a self test and initializes itself.

### 6.3.1 Connect the data interfaces

- Connect the computer to the LD-MRS using an ethernet cable.

### 6.3.2 Start the SOPAS-ET and open the scanning assistant

1. Start the SOPAS-ET.  
SOPAS-ET opens the program window with the English user interface by default.
2. To change the language setting, click CANCEL in the start dialogue and change the user interface language to an other language in the menu by going to TOOLS, OPTIONS.
3. Once the language has been changed, close SOPAS-ET and restart it.
4. In the dialog window, select the option CREATE NEW PROJECT and confirm with OK.
5. In the main window under SCAN ASSISTANT, click the button CONFIGURATION.  
The SCAN ASSISTANT dialog appears.

### 6.3.3 Configure the ethernet connection

**Important** Deactivate all the programs on your computer that access the ethernet or TCP/IP.

1. In the SCAN ASSISTANT dialogue, go to INTERNET PROTOCOL, IP COMMUNICATION and check the box ACTIVATE IP COMMUNICATION and USE AUTOIP.
2. Confirm the settings in the SCAN ASSISTANT dialog by clicking OK.  
The SCAN ASSISTANT dialog closes.

### 6.3.4 Run a scan

1. In the SCAN ASSISTANT dialogue, click the button START SCAN.
2. Select the listed devices and confirm with ADD DEVICE.  
The connected devices are searched over the connection.  
SOPAS-ET adds the listed devices to the project tree.

## 6.4 Initial startup

The LD-MRS is adapted to the local field monitoring by SOPAS-ET. A user-specific set of parameters is created with SOPAS-ET. The parameters set can either be loaded from the device (upload), or it can be created independently.

The parameter set is then loaded onto the LD-MRS (download). This is either done immediately (the SOPAS-ET option DOWNLOAD IMMEDIATELY) or manually (the SOPAS-ET command DOWNLOAD ALL PARAMETERS TO THE DEVICE).

**Important** ➤ After configuration, permanently save the parameter set on the LD-MRS.

**Recommendation** In addition, the parameter set can be saved as a project file (spr-file with configuration data) and archived on the computer.

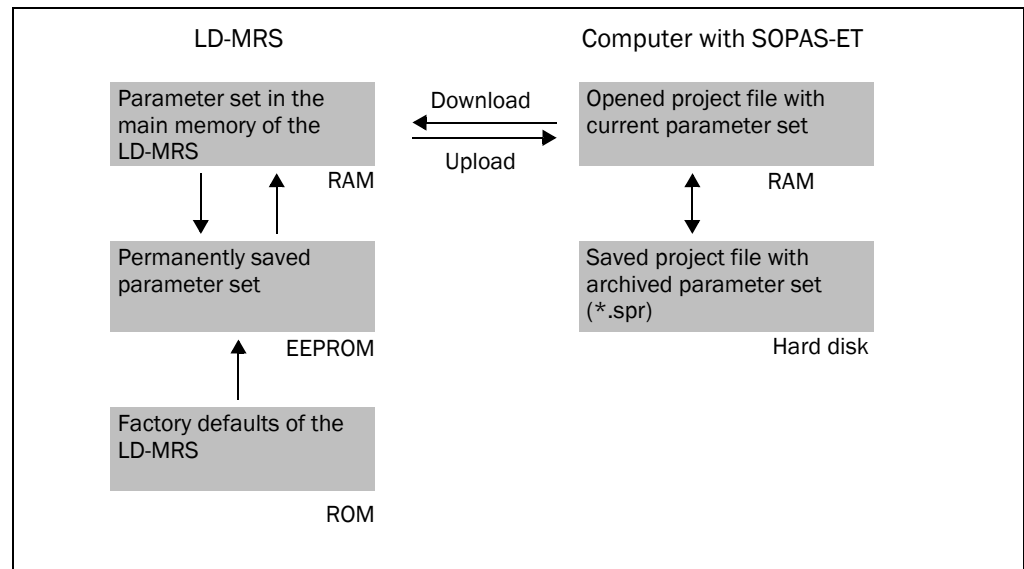

Fig. 6-1: Principle of data storage

#### 6.4.1 Configure the LD-MRS

You can configure the LD-MRS interactively using SOPAS-ET.

All of the configurable parameters for the LD-MRS are compiled in a device description (jar or sdd- file) for SOPAS-ET. You can access the parameters through the project tree for the device description.

The functions of the parameters are explained depending on the context in an online help (press [F1]). The valid value range and default are listed in the display window PARAMETER INFO (right-click when the pointer is over the parameter).

**Important** The program access to the LD-MRS is password protected. After configuration is successful, change the password to ensure protection.

User level	Password
Authorized client	Client

Tab. 6-2: Password

Use the structure of the project tree in SOPAS-ET to configure the required parameters for your application.

#### Do not turn off the power during configuration.

If the power is turned off during configuration, all of the configured parameters are lost.

1. In the OPTIONS menu, select the command LOG ON TO THE DEVICE, and log on with the password "client" as an AUTHORIZED CLIENT.
2. Configure the LD-MRS using the parameters in the SOPAS-ET for the desired application.

You can find help on using the program interface and individual options in SOPAS-ET:

#### Reset configuration

**Recommendation** To reset the LD-MRS back to its original settings, first export the data of a device with the original settings to a file. This device data can later be loaded to a configured device to reset the configuration to the original settings.

### 6.5 Conclusion and test measurement

Use the graphic scan display in SOPAS-ET to verify the generated measurements and measuring range online.

1. In the project tree, select LD-MRS /MONITOR/EVALUATION MONITOR.
2. To start measurement, click the button DISPLAY SCAN LINE.
3. Compare the measured line with the desired results.

**Important**

- The SCAN DISPLAY on the MONITOR depends on the available power of the computer and does **not** occur in real time. Consequently, not every measurement is visualized.
4. After the test measurement is over, permanently save the configuration on the LD-MRS: In the menu, go to LD-MRS/PARAMETERS/SAVE PERMANENTLY.

### 6.6 Synchronization

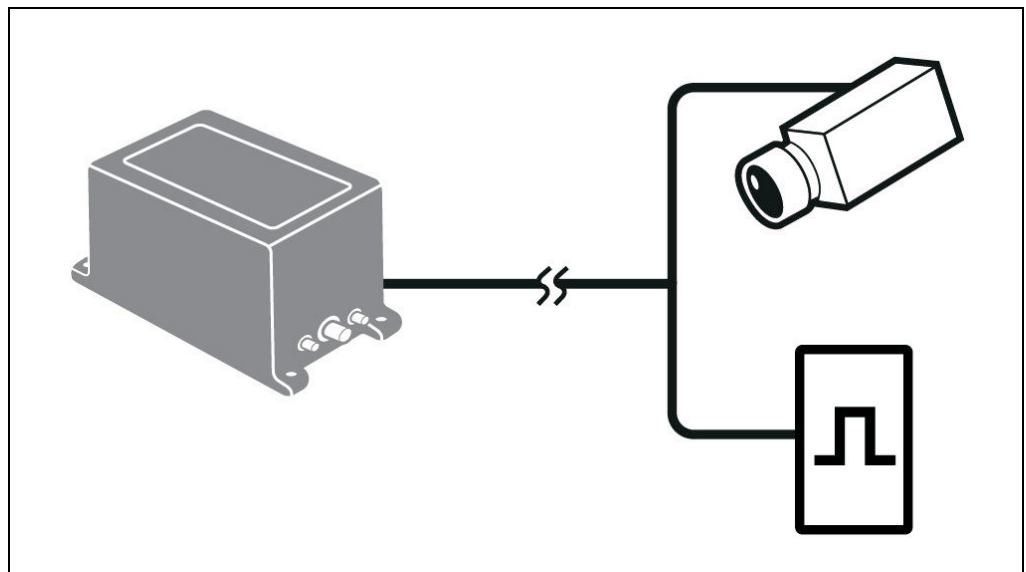

Fig. 6-2: Scheme of the data flow in a system with one LD-MRS and up to two external devices

Caption:

- 1 LD-MRS
- 2 "Data interfaces/synchronization" connecting line
- 3 External device (e.g. camera; optional)
- 4 External synchronization pulse signal generator (optional)

In a fusion system with an LD-MRS and an external device (e. g. a camera), the LD-MRS must be synchronized with the external component to minimize time shift during data collection of both components.

This reduces the necessity of scan data corrections during processing.

During the synchronization process, the LD-MRS adjusts its scanning frequency (in a small range) so that the measurement in a selected angle happens at the time the external device presents a synchronization pulse.

Another option is to define the LD-MRS as master which presents its synchronization pulse to the external device, which can adjust its processing frequency of measurement (e. g. taking pictures) to this synchronization signal.

### 6.6.1 Synchronization details

**Important** The synchronization frequency must be between 8.5 Hz and 50 Hz. Frequencies above and beyond these values are not accepted by the LD-MRS.

The precision of the synchronization (i. e. the time difference between synchronization pulse and the moment of crossing the angle that was specified as SyncAngle) is approx.  $\pm 1,000 \mu\text{s}$  for a scanning frequency of 12.5 Hz if no external forces act on the LD-MRS (especially no angle acceleration).

This is the equivalent of an angular precision of  $\pm 4.5^\circ$  around the true  $0^\circ$  direction. For the scanning frequency of 25 Hz and 50 Hz the precision is  $\pm 500 \mu\text{s}$ , equivalent to an angular precision of  $\pm 4.5^\circ$  or  $\pm 9^\circ$ , respectively.

The external synchronization frequency  $f_{\text{sync}}$  can be selected in a range of  $8.5 \text{ Hz} \leq f_{\text{sync}} \leq 50 \text{ Hz}$  and should have a relative precision better than 0.1 % (the better  $f_{\text{sync}}$ , the better the laser measurement sensor).

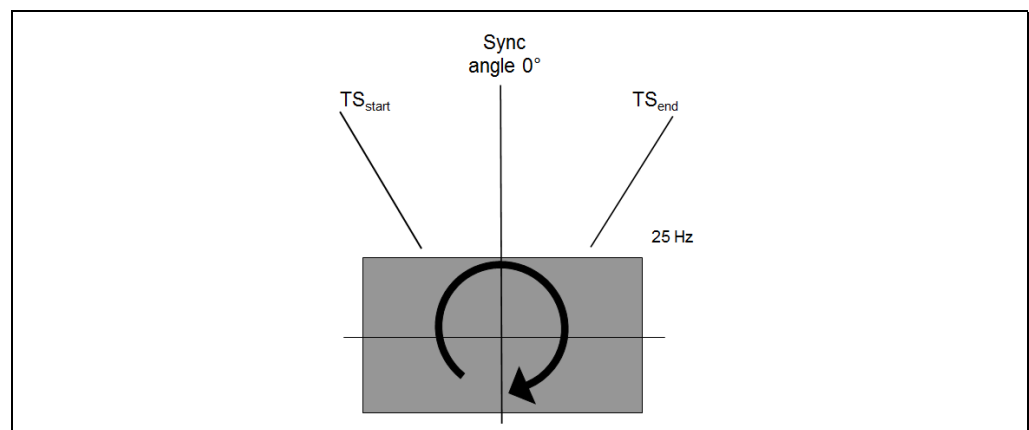

Fig. 6-3: Details synchronisation

Therefore we recommend not to send the synchronization signal from a PC because they generally have less precise timers. Instead use a designated micro-controller to generate the synchronization signal.

The external synchronization frequency and the scanning frequency do not need to match. The external synchronization frequency must be within  $\pm 4 \text{ Hz}$  of the scanning frequency  $f_{\text{scan}}$  ( $f_{\text{sync}} = f_{\text{scan}} \pm 4 \text{ Hz}$ ). The LD-MRS adjusts the scanning frequency to the external synchronization frequency.

When the external synchronization frequency fails, the LD-MRS adjusts its scanning frequency again to the initially specified value.

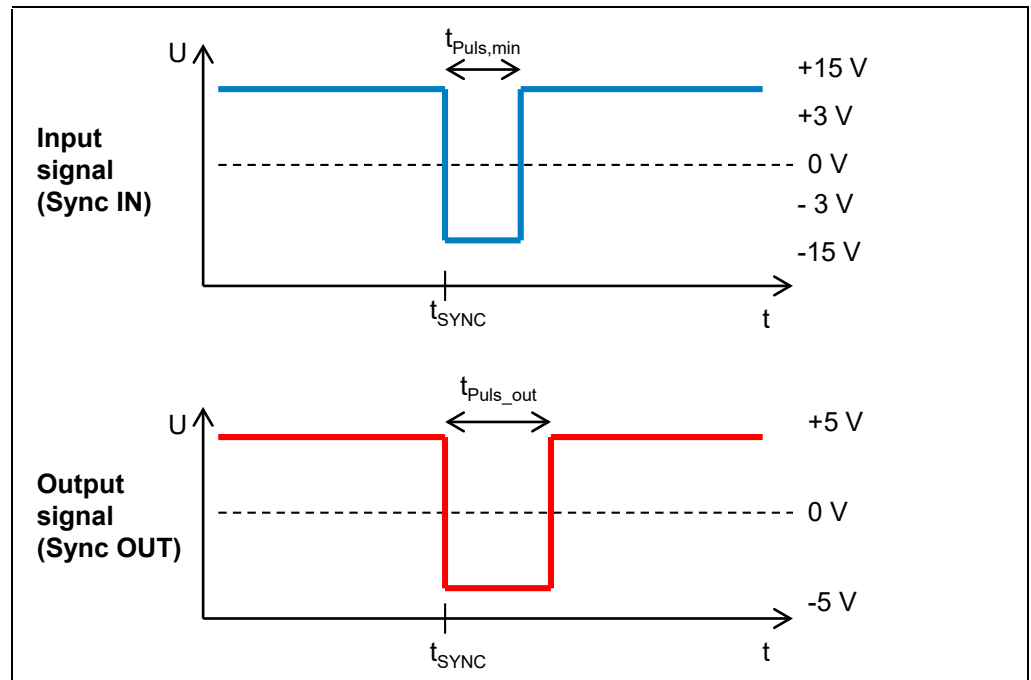

Fig. 6-4: LD-MRS: Sync IN and Sync Out pulse

The voltage level to detect an external trigger signal must have level E/A-232 (formerly RS-232).

The LD-MRS detects a logical positive flank as the moment of synchronization, see  $T_{\text{SyncTime}}$  in [Fig. 6-4](#).

### 6.6.2 Synchronization systems

There are three possible synchronization systems:

- LD-MRS and external device synchronized by the LD-MRS
- LD-MRS and external device synchronizing the LD-MRS
- LD-MRS and two external units, one of which synchronizes the LD-MRS, the other being synchronized by the LD-MRS

The external unit can also be a different LD-MRS.

Each LD-MRS starts as a master unit, sending trigger points to the next unit. The LD-MRS always sets the output signal to  $t_{\text{pulse\_out}} = 20 \mu\text{s}$ ; see the red output signal in [Fig. 6-4](#), [page 87](#).

When the trigger input receives a transition from low to high, the LD-MRS switches to the slave mode. This stops the further active sending of the Sync Pulse. The device then only copies and transmits the master trigger.

The external synchronization signal should remain in high state for at least  $t_{\text{Pulse,min}} = 10 \mu\text{s}$ , see blue input signal in [Fig. 6-4](#), [page 87](#).

If no other external trigger is present, the LD-MRS switches back to master mode after approx. 300 ms.

## 6.7 Switching off the LD-MRS

- Switch off the supply voltage of the LD-MRS.  
The parameter set most recently stored in the LD-MRS remains valid.

**Notes:**



## 7 Maintenance

### 7.1 Maintenance during operation

The LD-MRS is maintenance-free. In order to ensure laser class 1 of the LD-MRS, no maintenance is necessary.

The LD-MRS issues device and function errors via the Ethernet interface, see [Chapter 8.1 Warnings and fault messages, Page 91](#).

**Important** Breaking the seal and opening the device void any warranty claims against SICK AG. The housing may only be opened by authorized service personnel of SICK AG.

### 7.2 Cleaning the device

**Recommendation** In order to keep the complete measurement power of the LD-MRS, check the window of the LD-MRS on a regular basis (e. g. weekly) for contamination. This is particularly true in rugged operation environments (dust, debris, humidity).



## CAUTION

**Laser radiation!**

The LD-MRS uses infrared light laser. The device is specified as laser class 1 (eye-safe).

- Do not open the device (opening the housing does not interrupt the laser operation).
- Observe the valid laser protection regulations in their newest version.

#### 7.2.1 Cleaning the window from outside

## NOTICE

**Damaging the window!**

**Reduced measurement capabilities by scratches and streaks on the window!**

The window of the LD-MRS ([Fig. 2-1, page 14](#)) consists of a special plastic material. Only clean after a visual check.

- Do not touch the window with your fingers.
- Do not use aggressive detergents.
- Do not use paper towels for cleaning (can contain scratching wood particles!).
- Avoid scratching and abrasive movement on the window.

**Recommendation** Static charges cause dust particles to be attracted to the window. Reduce this effect by using the antistatic plastic cleaner (Part No. 5600006) and the lens cloth (Part No. 4003353), see [Chapter 10.3 Ordering information, Page 105](#).

**Clean window**

- Clean the window of the cover only with a damp cloth (lint-free) and a mild pane detergent, if necessary.

**Important** If the window is scratched or damaged (crack, break), the window must be replaced. To do so, contact SICK Service.

### 7.2.2 Cleaning the housing of the LD-MRS

## NOTICE

### Damages to the LD-MRS!

The LD-MRS is classified as enclosure rating IP 69k and is only protected against permeating liquids in that regard.

- Do not use aggressive chemicals!

---

- If necessary, clean the housing with a soft, damp cloth (lint-free). Use a mild antistatic window detergent.

If mounted, the LD-MRS can also be cleaned with a high pressure cleaner as long as the maximum values regarding pressure, duration and distance between high pressure cleaner and LD-MRS comply with DIN 40050. In addition, protect the plugs of the LD-MRS with suitable measures when cleaning with a high-pressure cleaning device because the plugs are classified as enclosure rating IP 68.

Else water can permeate the seals or damage parts of the LD-MRS housing.

### 7.3 Exchanging an LD-MRS

**Important** Only trained and authorized service personnel of SICK AG may repair the LD-MRS.

A faulty or damaged LD-MRS must be dismantled and replaced by a new or repaired LD-MRS.

#### 7.3.1 Exchanging the device

1. Switch off the supply voltage of the LD-MRS.
2. Unplug all of the device's plugs and remove the cables.
3. If necessary, appropriately mark the alignment of the LD-MRS.
4. Remove the LD-MRS from the holder.
5. Mount a new device in reverse sequence and connect it.
6. Switch on the supply voltage of the LD-MRS.

#### 7.3.2 Configure the new device.

##### Measuring mode:

The replaced LD-MRS must be reconfigured to the application with the SICK LaserView Customer Edition configuration program.



See the operating instructions, "SICK LaserView Customer Edition visualization tool" (Part no. 8013787), section "Changing and saving the configuration of the LD-MRS".

##### Field monitoring:

1. Use SOPAS-ET to load the parameter set for the application saved on the computer to the LD-MRS.
2. Test the LD-MRS for correct operation.

## 8 Troubleshooting

### 8.1 Warnings and fault messages

If a malfunction arises in the LD-MRS, it emits warning and error messages via the ethernet interface.

The operator can extract the warnings and fault messages from the Ethernet data stream. If the SICK LaserView Customer Edition is used to visualize the scan data, the errors are displayed there.



See the operating instructions, "SICK LaserView Customer Edition visualization tool (Part No. 8013786), section "Trace log".

The warnings and fault messages contain Bit fields, each Bit represents one warning or one fault. Available are a maximum of twice 16 Bit each for warnings and faults.

### 8.2 Overview of possible errors and faults

#### 8.2.1 Mounting error

- LD-MRS not mounted conveniently (e. g. limited field of vision)
- LD-MRS adjusted incorrectly (angle of rotation)

#### 8.2.2 Error in the electrical installation

- Interfaces of the LD-MRS switched incorrectly

#### 8.2.3 Parametrization error

- Device limits (scanning range) not considered
- The parameters are not adapted to local conditions.

#### 8.2.4 Fault during operation

- Device error (hardware/software)

### 8.3 Monitor error and fault indications

The LD-MRS monitors itself during operation:

- After switching on the supply voltage, the LD-MRS first runs a self-test checking important hardware components before initialization (loading the parameter set and initializing the device functions).
- In case of an error, the LD-MRS sends warning and error messages via the Internet interface; see [Chapter 8.1 Warnings and fault messages, Page 91](#).

## 8.4 Troubleshooting

The following tools are required for troubleshooting:

- A digital measurement device (measuring current/voltage)
- A computer with the SICK LaserView Customer Edition visualization tool and SOPAS-ET configuration software
- Tools

Fault	Possible cause	Rectification
1. SICK LaserView Customer Edition: Configuration. PC with SICK LaserView Customer Edition cannot communicate with the LD-MRS.	<ul style="list-style-type: none"> <li>• Supply voltage for LD-MRS not switched on.</li> <li>• PC not connected to LD-MRS.</li> </ul>	<ul style="list-style-type: none"> <li>• Check supply voltage, switch on.</li> <li>• Connect PC via Ethernet interface of the LD-MRS.</li> </ul>
2. Measurement mode: no scan data.	<ul style="list-style-type: none"> <li>• LD-MRS inconveniently mounted or adjusted.</li> <li>• LD-MRS parametrized incorrectly.</li> </ul>	<ul style="list-style-type: none"> <li>• Mount LD-MRS at more suitable place or readjust.</li> <li>• Set correct parameters for the LD-MRS.</li> </ul>
3. Field monitoring: No signals from the field violations	<ul style="list-style-type: none"> <li>• Field not assigned to an evaluation instance</li> <li>• Switching output not activated or incorrectly configured</li> </ul>	<ul style="list-style-type: none"> <li>• In SOPAS-ET: check the evaluation instance and provide the correct parameters if necessary.</li> <li>• In SOPAS-ET: check the CAN parameters. Check the configuration of the external outputs. Check the wiring between the LD-MRS and the CAN module.</li> </ul>
4. Field monitoring: The CAN modules are not working (correctly) (optional accessory)	<ul style="list-style-type: none"> <li>• The supply voltage V<sub>+</sub> is not connected to the CAN electronics, the poles are switched or it is not turned on</li> <li>• The supply voltage V<sub>p</sub> for the power driver (switching outputs) is not connected</li> <li>• Switch 8 for the CAN address dip switch was accidentally set to 1<sup>2)</sup> (for programming via an RS-232)</li> <li>• Incorrect transmission rate</li> <li>• Wrong termination</li> <li>• CAN addressed several times</li> <li>• The logical inputs/outputs in the LD-MRS incorrectly assigned to the physical I/O ports in the CAN modules</li> <li>• The switching logic of the inputs/outputs is inverted, active high, active low</li> </ul>	<ul style="list-style-type: none"> <li>• Connect the supply voltage (8 to 50 V DC) to V<sub>+</sub> and GND and turn on if necessary</li> <li>• For example, bridge the supply voltage to V<sub>+</sub> to V<sub>p</sub></li> <li>• Set switch 8 for the CAN address dip switch to 0<sup>2)</sup></li> <li>• In each CAN module, set a transmission rate of 500 kBit/s (set the dip switch transmission rate from left to right: 1110)<sup>2)</sup></li> <li>• Activate the termination in both modules with the Termination switch. If there is only one CAN module, terminate the open bus end with a 120 Ohm resistance.</li> <li>• Configure a unique CAN address for each bus user</li> <li>• Check the assignment of the logical inputs/outputs in SOPAS-ET</li> <li>• Check the assignment of the switching logic in SOPAS-ET</li> </ul>

1) For additional assistance, see the chapter "Diagnosis" in the manual for the CAN module on the CD, "Manuals & Software LD-MRS" (Part No. 2050246)  
2) 1 = ON, 0 = OFF

Tab. 8-1: Troubleshooting the LD-MRS

## 8.5 SICK Support

If an error can not be rectified by the listed measures, the LD-MRS might be defective. The operator can not repair the LD-MRS and thus restore its functionality after a fault. However, the LD-MRS can be rapidly replaced by the user. See [Chapter 7.3 Exchanging an LD-MRS, Page 90](#).

If an error occurs which cannot be eliminated, please contact SICK Service:

- International: Competent SICK branch office or SICK subsidiary
  - For telephone numbers and e-mail addresses please see the *back page* of these operating instructions
  - For the postal address please visit [www.sick.com](http://www.sick.com).
- Only return device after consultation with the SICK Service.

**Important** Only trained and authorized service personnel of SICK AG may repair the LD-MRS.

## 9 Technical specifications

### 9.1 Data sheets

#### 9.1.1 Data sheet for the laser measurement sensor LD-MRS

Type	LD-MRS400001 (Standard)	LD-MRS400102 (Heavy-Duty)	LD-MRS420201 (UAV)	LD-MRS800001 (Standard-Version up to 8 layers)
Part No.	1045046, 1052960	1047145, 1052961	1085081	1069408
Distance measurement range	0.3 to 50 m (0.9 to 164 ft) to 10 % remission	0.3 to 30 m (0.9 to 98.4 ft) to 10 % remission	0.3 to 30 m (0.9 to 98.4 ft) to 10 % remission	0,3 ... 50 m auf 10 % remission
Scan planes	4, vertical aperture angle over 4 planes: 3.2°			8 scan planes, vertical aperture angle over 8 layers: 5,6° ±0,2° 4,2° (±0,2°) @ 50° scan angle 5,6° (±0,2°) @ 0° scan angle 6,4° (±0,2°) @ -50° scan angle
Usable horizontal aperture angle (sector)	4 scan planes: 85° + 2 scan planes: 110°; overlapping ranges			8 scan angles: 85° + 4 scan angles: 110°; overlapping ranges
Angular resolution (step width)	Min. 0.125° (interlaced) / 0,25° / 0,5°			
Scanning frequency	<b>Measuring mode:</b> 12.5 Hz (0.125 ... 0.5°)/12.5 Hz (0.25°)/25 Hz (0.25°)/50 Hz (0.5°) <b>Tracking (only article no. 105260, 1052961 und 108081):</b> 12,5 Hz (0,25°) / focused (0,125°...0,5°) / flex. res. (0,125°...0,5°) <b>Field monitoring (only article no. 1045046, 1047145):</b> 12.5 Hz (0.25°)/25 Hz (0.25°)/50 Hz (0.5°)			Measuring mode: 12,5 Hz (0,125 ... 0,5°)/12,5 Hz (0,25°)/25 Hz (0,25°)/50 Hz (0,5°) Tracking: 12,5 Hz (0,25° / focused (0,125 ... 0,5°) / Flexible resolution (0,125 ... 0,5°)
Measurement resolution	40 mm (1.58 in)			
Statistical error (1 sigma)	100 mm (3.94 in)			
Beam divergence	Horizontal 0.08°, vertical 0.8° per layer, per laser 1.6°			
Echoes per individual measurement	3			
Field monitoring	16 evaluation fields/instances, 1 of 3 evaluation strategies per field, 2 logical inputs, 10 logical outputs (AND or OR link to evaluation instances)		no field monitoring	
Power-up delay	15 s (at an operation environment temperature of 20 °C (+68 °F))			
Light sources	2 laser diodes, infrared light (895 to 915 nm)			
Laser safety class of the unit	Class 1 acc. EN 60825-1:2014, 21 CFR 1040.10 and 1040.11			
Optical indicators	None			
Configuration	Measuring mode: with SICK LaserView Customer Edition visualization tool or messages Field monitoring: with SOPAS-ET configuration software			
Switching inputs/outputs	Measuring mode: none Field monitoring: 2 inputs/10 outputs (realized externally with a maximum of two optional CAN modules with 8 configurable I/O ports)		no switching inputs/outputs	
Ethernet data interface	100 Mbit, TCP/IP, full duplex, measurement output for measuring mode			
Data interface RS-232	Auxiliary interface, 57.6 Kbd, 8 data bits, no parity, 1 stop bit (values cannot be modified)			
Data interface CAN	500 KBit/s (fest), address range 0 to 127, max. line length: 100 m (328 ft)			

Tab. 9-1: Technical specifications LD-MRS

## LD-MRS

Type	LD-MRS400001 (Standard)	LD-MRS400102 (Heavy-Duty)	LD-MRS420201 (UAV)	LD-MRS800001 (Standard-Version up to 8 layers)
Electrical connection	Ethernet: 4-pin round socket Data interfaces (RS-232, CAN)/synchronization: 12-pin round socket Power: 4-pin plug (round plug-in connection)			
Supply voltage	9 to 27 V DC, typically 12 /24 V DC, polarity proof			
Power consumption	Max. 10 W, typically 8 W, on start-up shortly 36 W			
Housing	Aluminium, window: polycarbonate			
Housing color	Grey (RAL 7032) /Grey UAV (RAL 7042) / black (RAL 9005), weatherproof alloy			
Dimensions (H x W x D)	88 mm x 164.5 mm x 93.2 mm (including fastening tabs)		88 mm x 164,5 mm x 91,3 mm (including fastening tabs)	88 mm x 164.5 mm x 93.2 mm (including fastening tabs)
Weight	Approximately 1 kg (2.2 lb.) / UAV Approximately 0,77 kg (1,69 lb.)			
Electrical safety	As per EN 50178 (1997-10)			
Enclosure rating	IP 69k, plug IP 68 (2 m/ 24 h) as per EN 60529 (1991-10) + A1:2000-02			
EMC test	Radiated emissions: as per EN 61000-6-3 (2007-01) Noise immunity: as per EN 61000-6-2 (2005-08)			
Vibration resistance	Vibration, sinus-shaped as per EN 60068-2-6 (1995-04) Vibration broadband noise (digitally controlled) and conductive paths as per EN 60068-2-64 (1994-06)			
Shock resistance	Continuous shock as per EN 60068-2-29 (1993-04)			
Operating/storage temperature range	-40 to +70 °C/-40 to +95 °C (-40 to +158 °F/-40 to +203 °F)			
Max. rel. humidity	EN 60068-2-30 (2005-12); method Db, variant 1			
Mounting	Any position, 4x mounting lugs with hole Ø 6.6 mm			

Tab. 9-1: Technical specifications LD-MRS (contd.)

## 9.1.2 CAN module data sheet, Part no. 6038825/6041328 (optional accessory)

Type	$\mu$ CAN.8.dio-SNAP	$\mu$ CAN.8.dio-BOX
Part No.	6038825	6041328
Function	Recording and outputting digital signals via a CAN bus, max. 8 configurable I/O ports, no separation of potential between the bus and ports	
Optical indicators	1 two-color LED (status display)	10 two-color LEDs (status display)
Configuration	2 DIP switches/1 switch/1 jumper	2 dip switches/1 switch
Data interface CAN	20 kBit/s to 1 MBit/s	
Digital switching inputs	High side/low side input (configurable by jumpers or terminal wiring) Low: $V_{in} < 0.4 \times V_S$ , High: $V_{in} > 0.6 \times V_S$ , input resistance 24.2 kOhm No galvanic isolation between the inputs	
Digital switching outputs	High side switch, $I_{OUTmax} = 500$ mA per output, sustained short-circuit proof, total current of all outputs: max. 6 A, no galvanic isolation between outputs	
Electrical connection	16 screw terminals	36 cage clamps
Supply voltage ( $U_V$ )	8 to 50 V DC, protected against polarity reversal	
Power consumption	1.5 W (60 mA at DC 24 V) without load	
Housing/housing color	Plastic (PA 66 FR)/ grey/black	Aluminum/ gray/black
Dimensions (H x W x D)	99 mm x 22.5 mm x 114.5 mm	125 mm x 80 mm x 57 mm without cable glands <sup>1)</sup>
Threaded holes for cable glands	-	4 x M16 x 1.5 3 x M20 x 1.5
Weight	approx. 150 g (5.3 oz.)	Approximately 515 g (18.2 oz.) without cable glands <sup>1)</sup>
Enclosure rating	IP 20	IP 67
EMC test	Emitted interference: according to EN 50081-2, EN 55022, class A; EN 61000-6-4 (2001) Noise immunity: according to EN 50082-2, EN 61000-6-2 (2001)	
Ambient operating temperature	-40 to +85 °C (-40 to +185 °F)	
Mounting	Snap-in on TS35 top hat rail in the control cabinet	2 holds for M4 screws
<sup>1)</sup> Set of cable glands (metal), Part no. 6043917 deliverable as optional accessory, consisting of: 2 cable glands M16 x 1.5 for a line diameter of 5 to 9 mm (0.2 to .35 in), 3 cable glands M20 for a line diameter of 10 to 14 mm (0.39 to 0.55 in) including filler plug, 2 dummy covers M16, 3 dummy covers M20		

Tab. 9-2: Technical specifications for the CAN modules (from the manufacturer's data sheets and manuals)



LD-MRS

9.2 Dimensional drawings

9.2.1 LD-MRS laser measurement sensor: Dimensions

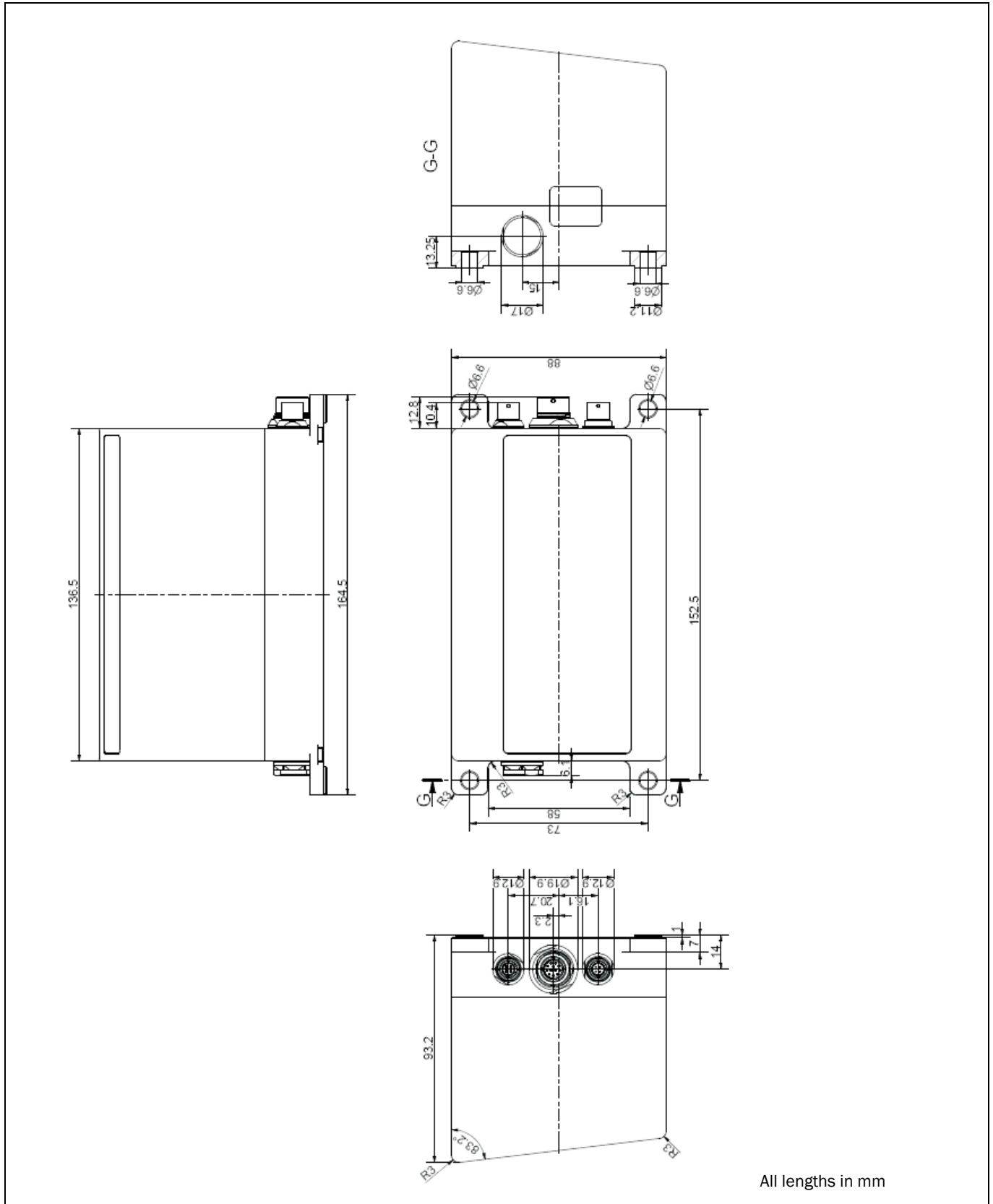
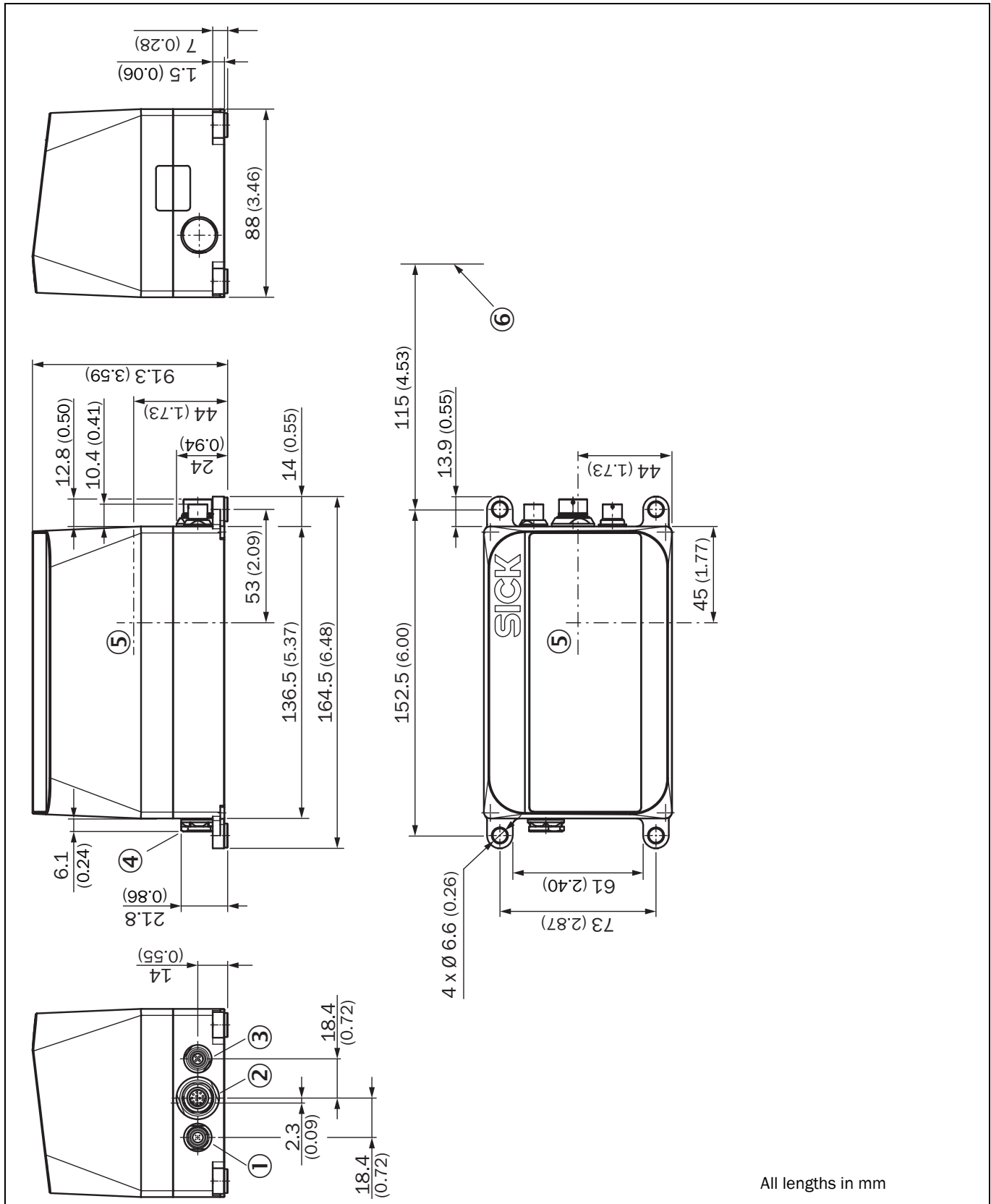

Fig. 9-1: Dimensions of the LD-MRS

9.2.2 LD-MRS laser measurement sensor: Dimensions



All lengths in mm

Fig. 9-2: Dimensions of the LD-MRS UAV

9.2.3 Laser measurement sensor LD-MRS UAV: sensor coordinate origin

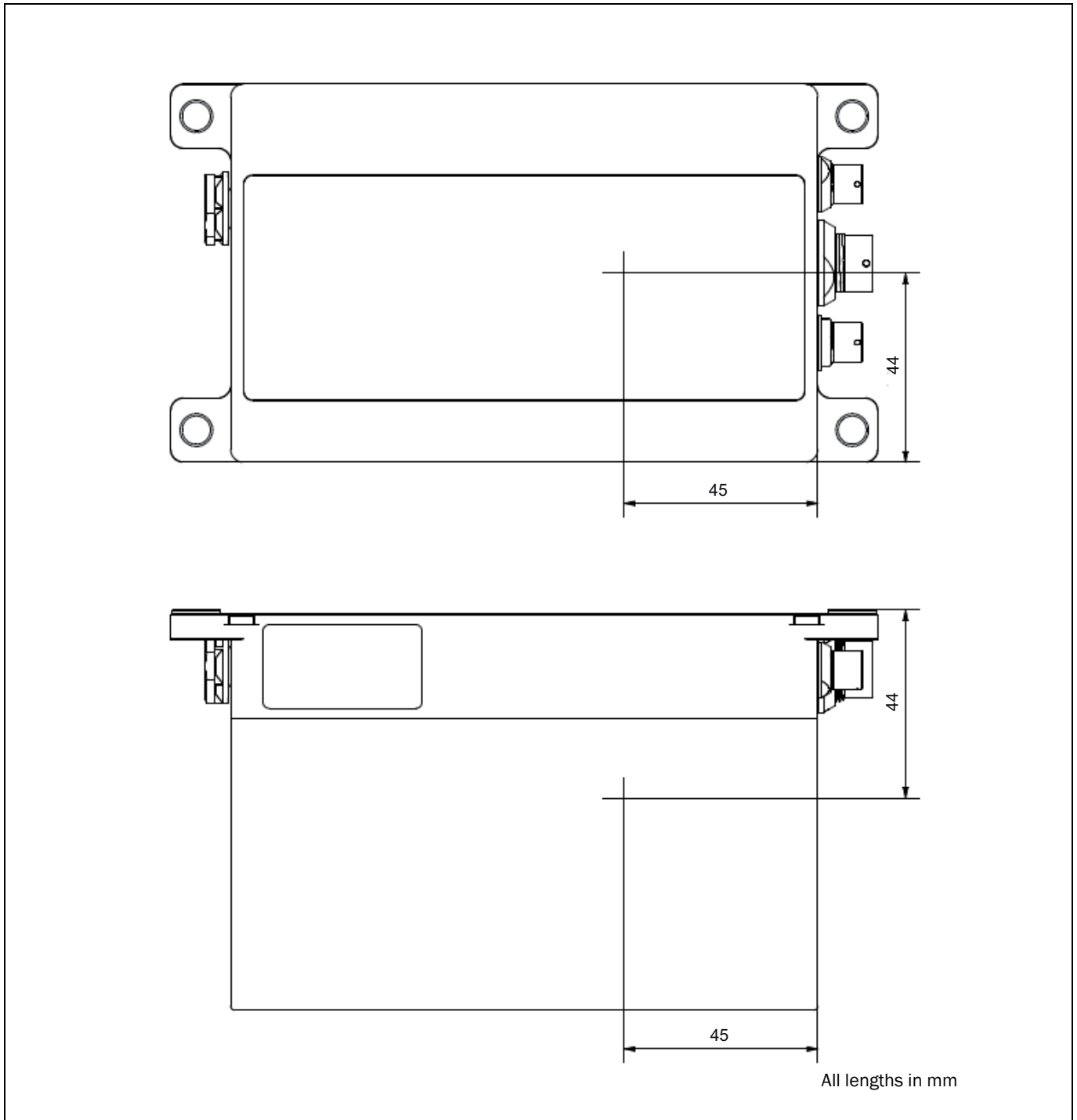

Fig. 9-3: Position of the sensor coordinate origin in the LD-MRS

9.2.4 Holder (optional accessory)

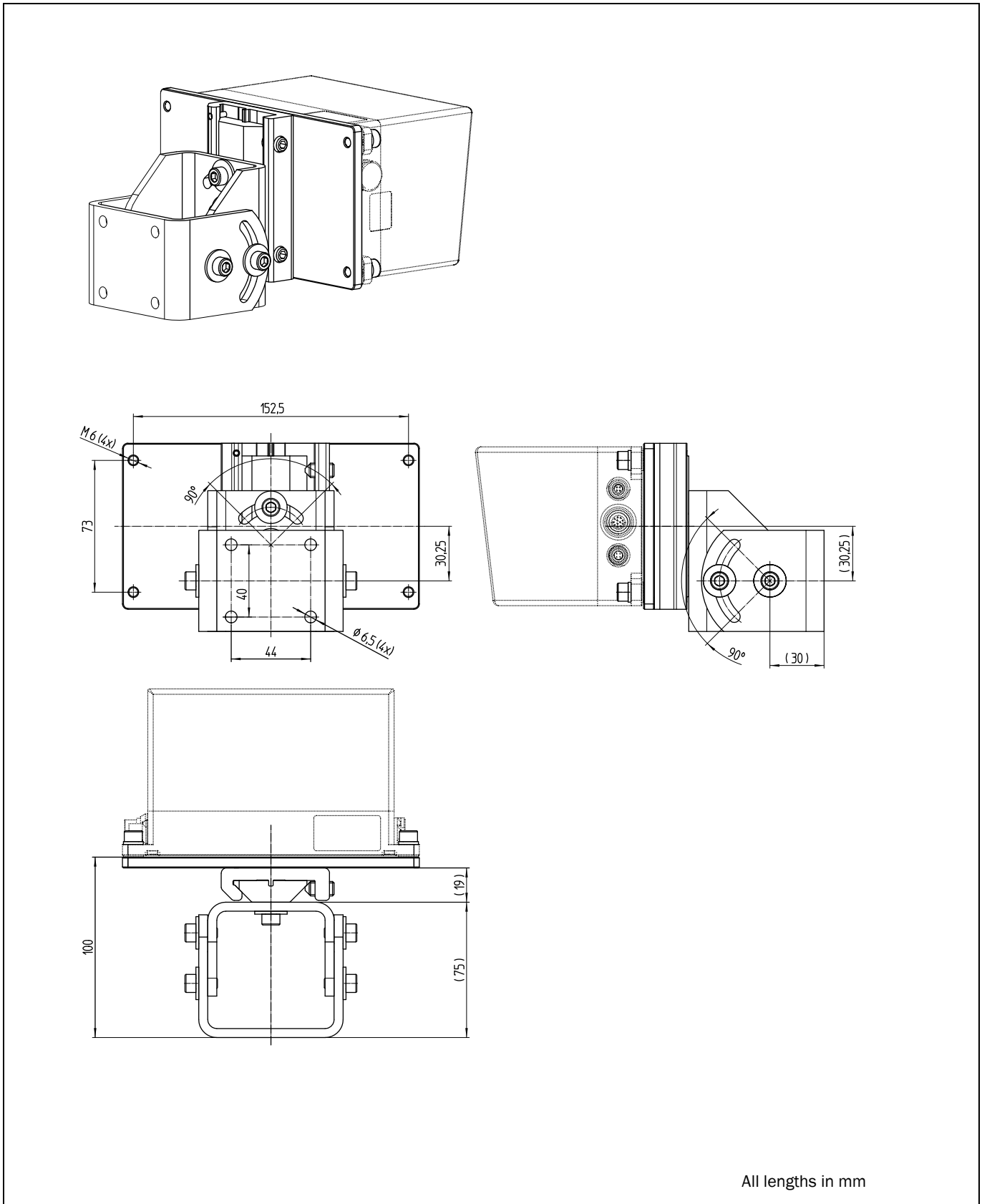

Fig. 9-4: Dimensions of the holder Part No. 1047429

9.2.5 Weather resistant cover (optional accessory)

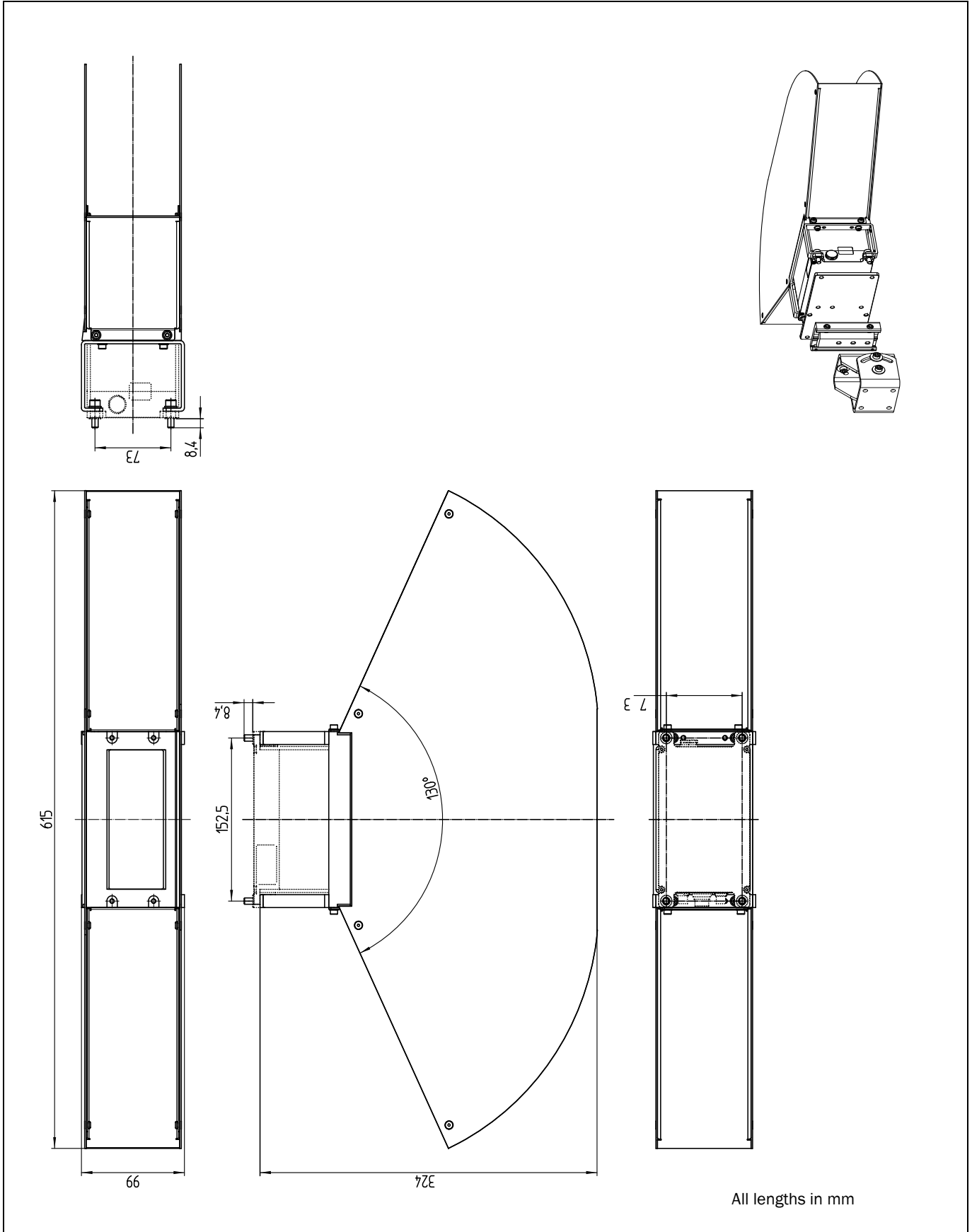

Fig. 9-5: Dimensions of the weather resistant cover Part no. 2058033

9.2.6 CAN modules (optional accessory)

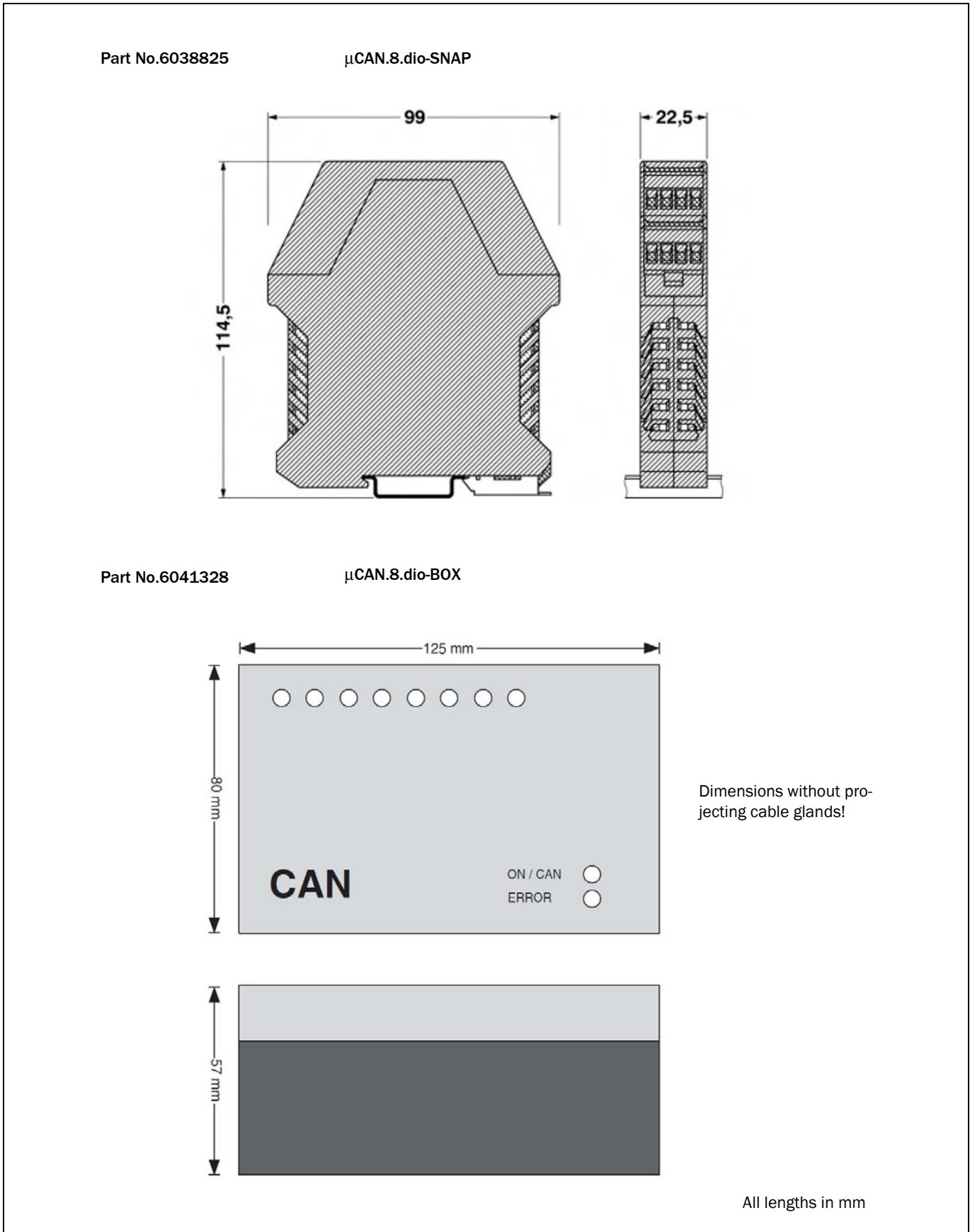

Fig. 9-6: Dimensions of the two designs of the CAN modules

9.2.7 Shock mounting

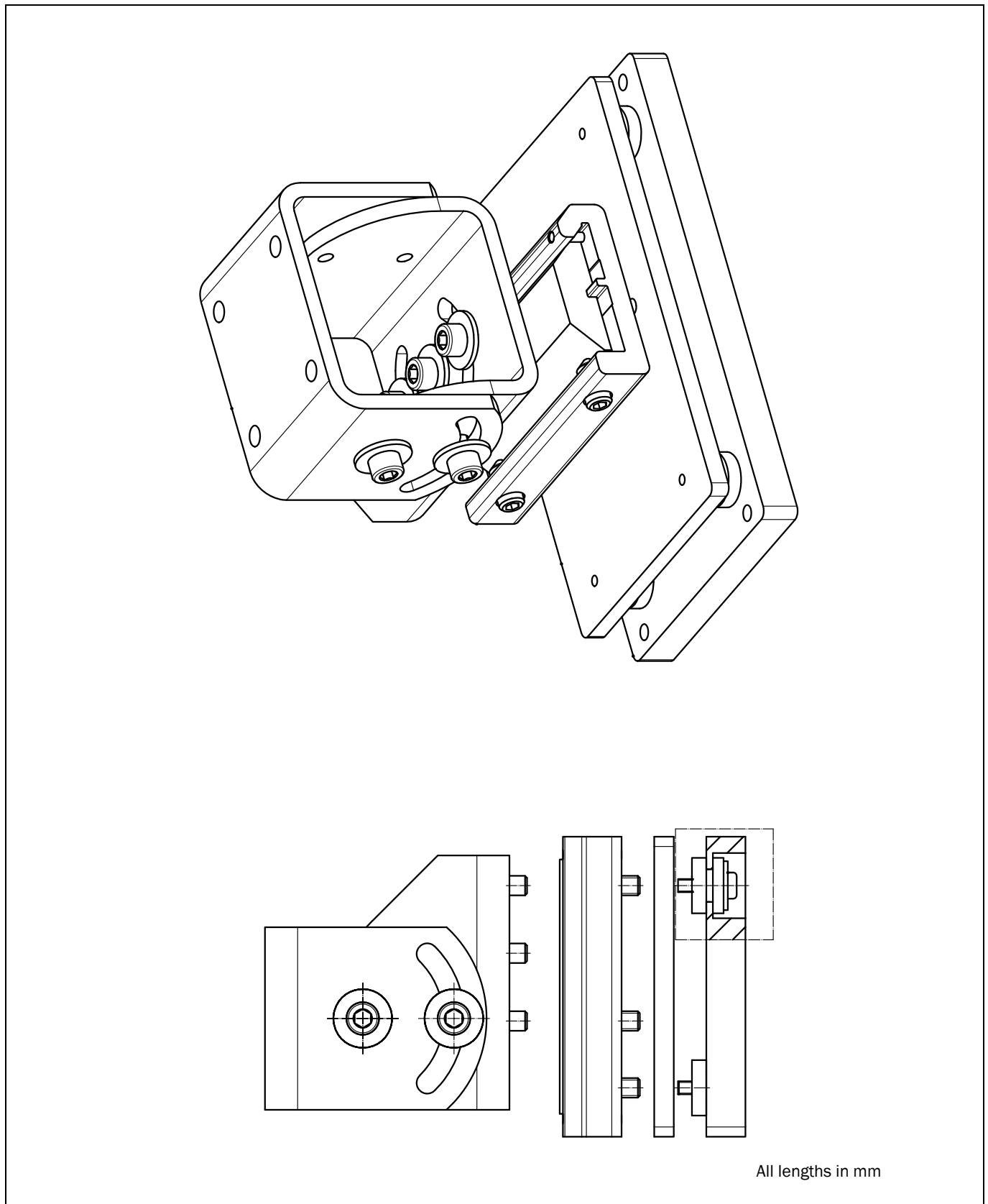

Fig. 9-7: Dimensions of the shock mounting

### 9.3 Conditions for integrating the LD-MRS

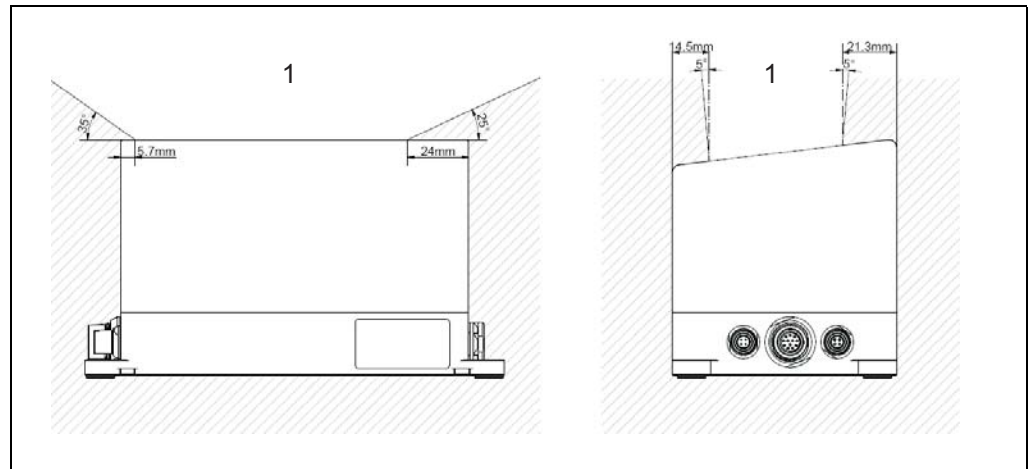

Fig. 9-8: Boundary conditions for integration

Caption:

1 Area to keep clear

**Recommendation** The following measures make it easier to integrate the LD-MRS in a vehicle:

- When integrating the LD-MRS, keep at least the marked areas clear.
- Additionally only use materials with a low remission as materials bordering to the field of view.
- Avoid edges close to the window of the LD-MRS. For optimum design integration the transition between the surrounding material and the LD-MRS should be smooth.

Together with SICK AG, a customer-specific solution for the housing cover of the LD-MRS can be developed, so that it adjusts to the conditions on the vehicle and that the vehicle contour fits smoothly and without edges into the contour of the LD-MRS.



## 10 Annex

### 10.1 Overview of the annex

The annex contains the following supplements and additions:

- [Additional documentation](#)
- [Ordering information](#)
- [Glossary](#)
- [EC Declaration of Conformity](#)

### 10.2 Additional documentation

Part No.	Title	Language	Contents
8013787	Operating instructions for the "SICK LaserView Customer Edition visualization tool"*)	English	Installation and use of the SICK LaserView Customer Edition software
8013906	Manual "μCAN.8.dio-SNAP module"*)	English	Detailed technical description of the module
8013908	Manual "μCAN.8.dio-BOX module"*)	English	Detailed technical description of the module
8014492	Telegramm Listing Ethernet Data Protocol	English	Detailed technical description of the parametrization
8014493	Telegramm Listing CAN Data Protocol	English	Detailed technical description of the parametrization

\*) Available as a PDF on the CD "Manuals & Software Laser Measurement Sensor LD-MRS"

Tab. 10-1: Additional documentation

### 10.3 Ordering information

The ordering information on the product and accessories are available at [www.sick.com](http://www.sick.com).

#### 10.3.1 Consumables

Part No.	Type	Description
4003353	Lens cloth	Special cloth for proper cleaning of the window
5600006	Plastic detergent	Antistatic, mild detergent solution

Tab. 10-2: Consumables for the care of the LD-MRS

## 10.4 Glossary

### **SICK LaserView Customer Edition**

Visualization tool for configuring (adapting to the requirements and the situation of use), and for starting the LD-MRS visualization tool for measuring mode. The operating instructions "SICK LaserView Customer Edition visualization tool" describe how to install and use the software (Part No. 8013787, English version).

### **Download**

Procedure for transmitting the parameter set from the SICK LaserView Customer Edition visualization tool/SOPAS-ET configuration program on the computer to the LD-MRS when for example parameters were changed.

### **SOPAS-ET configuration software**

For configuring (adapting to requirements and the situation of use) and starting the LD-MRS for field monitoring.

### **Parameter set**

Data set which serves for initializing and activating the functions implemented in the LD-MRS. The parameters for field monitoring can be saved on the computer as a configuration file under SOPAS-ET.

### **Remission**

Remission is the quality of reflection at a surface. The basis is the Kodak standard, known world-wide in, among other areas, photography.

### **Scan**

A scan encompasses all measured values determined referred to the scanning angle and the speed of rotation of the mirror.

### **Upload**

The procedure for transmitting the parameter set from the LD-MRS to the SICK LaserView Customer Edition visualization tool/SOPAS-ET configuration software. The parameters are shown on the computer in the program window where they can be modified.

**10.5 EC Declaration of Conformity**

Fig. 10-1 shows page 1 of the EC Declaration of Conformity (size reduced) for the LD-MRS.

- If needed, you can download the complete EC statement of conformity (with a list of the device versions and satisfied standards as a PDF file from the product page of the LD-MRS on the SICK Partner Portal under [www.sick.com](http://www.sick.com).



Fig. 10-1: Illustration containing the EC Declaration of Conformity, page 1 (size reduced)

**Australia**

Phone +61 3 9457 0600  
1800 334 802 – tollfree  
E-Mail sales@sick.com.au

**Austria**

Phone +43 22 36 62 28 8-0  
E-Mail office@sick.at

**Belgium/Luxembourg**

Phone +32 2 466 55 66  
E-Mail info@sick.be

**Brazil**

Phone +55 11 3215-4900  
E-Mail marketing@sick.com.br

**Canada**

Phone +1 905 771 14 44  
E-Mail information@sick.com

**Czech Republic**

Phone +420 2 57 91 18 50  
E-Mail sick@sick.cz

**Chile**

Phone +56 2 2274 7430  
E-Mail sales@schadler.com

**China**

Phone +86 20 2882 3600  
E-Mail info.china@sick.net.cn

**Denmark**

Phone +45 45 82 64 00  
E-Mail sick@sick.dk

**Finland**

Phone +358-9-2515 800  
E-Mail sick@sick.fi

**France**

Phone +33 1 64 62 35 00  
E-Mail info@sick.fr

**Germany**

Phone +49 211 5301-301  
E-Mail info@sick.de

**Hong Kong**

Phone +852 2153 6300  
E-Mail ghk@sick.com.hk

**Hungary**

Phone +36 1 371 2680  
E-Mail office@sick.hu

**India**

Phone +91 22 4033 8333  
E-Mail info@sick-india.com

**Israel**

Phone +972 4 6881000  
E-Mail info@sick-sensors.com

**Italy**

Phone +39 02 274341  
E-Mail info@sick.it

**Japan**

Phone +81 3 5309 2112  
E-Mail support@sick.jp

**Malaysia**

Phone +6 03 8080 7425  
E-Mail enquiry.my@sick.com

**Mexico**

Phone +52 472 748 9451  
E-Mail mario.garcia@sick.com

**Netherlands**

Phone +31 30 2044 000  
E-Mail info@sick.nl

**New Zealand**

Phone +64 9 415 0459  
0800 222 278 – tollfree  
E-Mail sales@sick.co.nz

**Norway**

Phone +47 67 81 50 00  
E-Mail sick@sick.no

**Poland**

Phone +48 22 539 41 00  
E-Mail info@sick.pl

**Romania**

Phone +40 356 171 120  
E-Mail office@sick.ro

**Russia**

Phone +7 495 775 05 30  
E-Mail info@sick.ru

**Singapore**

Phone +65 6744 3732  
E-Mail sales.gsg@sick.com

**Slovakia**

Phone +421 482 901201  
E-Mail mail@sick-sk.sk

**Slovenia**

Phone +386 591 788 49  
E-Mail office@sick.si

**South Africa**

Phone +27 11 472 3733  
E-Mail info@sickautomation.co.za

**South Korea**

Phone +82 2 786 6321  
E-Mail info@sickkorea.net

**Spain**

Phone +34 93 480 31 00  
E-Mail info@sick.es

**Sweden**

Phone +46 10 110 10 00  
E-Mail info@sick.se

**Switzerland**

Phone +41 41 619 29 39  
E-Mail contact@sick.ch

**Taiwan**

Phone +886 2 2375-6288  
E-Mail sales@sick.com.tw

**Thailand**

Phone +66 2645 0009  
E-Mail Ronnie.Lim@sick.com

**Turkey**

Phone +90 216 528 50 00  
E-Mail info@sick.com.tr

**United Arab Emirates**

Phone +971 4 88 65 878  
E-Mail info@sick.ae

**United Kingdom**

Phone +44 1727 831121  
E-Mail info@sick.co.uk

**USA**

Phone +1 800 325 7425  
E-Mail info@sick.com

**Vietnam**

Phone +84 945452999  
E-Mail Ngo.Duy.Linh@sick.com

Further locations at [www.sick.com](http://www.sick.com)